



Alaşım Alüminyum

ALUMINIUM PROFILE CATALOGUE





## İÇİNDEKİLER / CONTENTS

|   |     |
|---|-----|
| Hakkımızda ( <i>About Us</i> )                                  | 3   |
| Perde Profilleri ( <i>Blinds Profiles</i> )                     | 5   |
| Sineklik Profilleri ( <i>Swatter Profiles</i> )                 | 40  |
| Yer Kaplama Profilleri ( <i>Flooring Profiles</i> )             | 44  |
| Karöser Profilleri ( <i>Truck Profiles</i> )                    | 51  |
| Mobilya Profilleri ( <i>Furniture Profiles</i> )                | 52  |
| Dekorasyon Profilleri ( <i>Decoration Profiles</i> )            | 66  |
| Menfez Profilleri ( <i>Climates Profiles</i> )                  | 70  |
| Aydınlatma ( <i>Lighting Profiles</i> )                         | 92  |
| Temizlik Profilleri ( <i>Cleaning Profiles</i> )                | 117 |
| Kurutmalık Profilleri ( <i>Drying Profiles</i> )                | 122 |
| Tente ve Branda Profilleri ( <i>Awining Profiles</i> )          | 127 |
| Ofis Bölme Profilleri ( <i>Office Partition Profiles</i> )      | 131 |
| Pencere - Aldoks Profilleri ( <i>Window - Aldoks Profiles</i> ) | 141 |
| Pencere - C60 Profilleri ( <i>Window - Aldoks Profiles</i> )    | 143 |
| Cam Balkon Profilleri ( <i>Glass Balcony Profiles</i> )         | 145 |
| Küpeşte Profilleri ( <i>Handrail Profiles</i> )                 | 147 |
| Boru Profilleri ( <i>Tubes Profiles</i> )                       | 153 |
| Kutu ve Mastar Profilleri ( <i>Box Profiles</i> )               | 163 |
| L Profilleri ( <i>L Profiles</i> )                              | 167 |
| U Profilleri ( <i>U Profiles</i> )                              | 170 |
| Lama Profilleri ( <i>Flat Bar Profiles</i> )                    | 172 |
| Özel Profilleri ( <i>Special Profiles</i> )                     | 173 |
| Kepenik (Panjur) Profilleri ( <i>Shutter Profiles</i> )         | 194 |



Alaşım Alüminyum

## ALAŞIM ALUMİNYUM

Sektördeki 10 yılı aşkın tecrübemiz, yenilikçi ve dinamik yaklaşımımız, kalite ve ürün çeşitliliğine olan bağlılığımızla birleştirerek, her zaman güvenilir ve kaliteli ürün ve hizmetler sunmak için çalışıyoruz.

Tasarımdan Gerçeğe sloganıyla yola çıkan firmamız siz değerli müşterilerimizin ihtiyaçlarını metal sektöründen edindiği detay çözme yetenek ve tecrübe ile hayata geçirmektedir. Alaşım Alüminyum Profil ve Mekanik İşlem San. Tic. Ltd. Şti.'nin faaliyeti; Alüminyum profil, Alüminyum Tel, paslanmaz, pirinç, bakır ve alüminyum metallerini işlemekte olup özel projeleri ve tasarımları kendi tesislerinde üretilip uygulamasını yapmaktadır.

Müşteri odaklı çalışan firmamızda, kalite, maliyet ve zamanında teslimat ana prensipleri oluşturmaktadır. Hammaddeden girişinden mamul çıkışına kadar olan her adımda uygulanan kontrol sistemleri, laboratuvar deneyleri, ürünlere yönelik denetim testleriyle mamul kalitesi güvence altına alınmıştır.

Modern teknolojiyi takip eden makine parkı ve eğitimli personeliyle çalışmalarını sürdüren firmamız açısından önemli olan müşteri memnuniyet göstergeleri titizlikle takip edilip değerlendirilmektedir.



Alaşım Alüminyum

## ALAŞIM ALUMINUM

Throughout our experience of over 10 years in the industry, our innovative and dynamic approach, combined with our commitment to quality and product diversity, we always work towards providing reliable and high quality products and services.

Our company, which sets out with the slogan From Design To Reality, realizes the needs of our valued customers, with the ability to solve details and experience gained from the metal industry. Alaşım Alüminyum Profil ve Mekanik İşlem San. Tic. Ltd. Şti.'s activity; Aluminum profiles, Aluminium Wire, Stainless, Brass, Copper and Aluminum Metals and produces and implements special projects and designs in its own facilities.

In our customer-oriented company; quality, cost and timely delivery are our main principles. Product quality is guaranteed with control systems, laboratory experiments and inspection tests for products, which are applied at every step from raw material entry to product exit.

Customer satisfaction indicators, which are important for our company, which continues to work with its machinery and trained personnel following modern technology, are carefully monitored and evaluated.



Alaşım Alüminyum

|              |  |       |
|--------------|--|-------|
| <b>10452</b> | Çevre (mm)<br><i>Perimeter</i>         | 107.7 |
|              | Alan (mm <sup>2</sup> )<br><i>Area</i> | 71.6  |
|              | Ağırlık (gr/m)<br><i>Weight</i>        | 195   |



|              |  |     |
|--------------|--|-----|
| <b>10372</b> | Çevre (mm)<br><i>Perimeter</i>         | 97  |
|              | Alan (mm <sup>2</sup> )<br><i>Area</i> | 70  |
|              | Ağırlık (gr/m)<br><i>Weight</i>        | 190 |

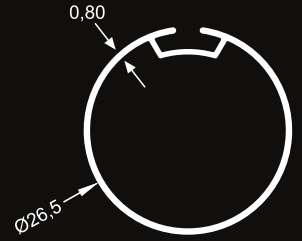

|              |  |     |
|--------------|--|-----|
| <b>10268</b> | Çevre (mm)<br><i>Perimeter</i>         | 113 |
|              | Alan (mm <sup>2</sup> )<br><i>Area</i> | 70  |
|              | Ağırlık (gr/m)<br><i>Weight</i>        | 190 |

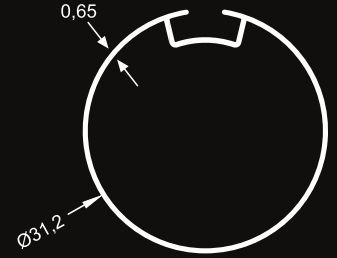

|                |  |     |
|----------------|--|-----|
| <b>10268-S</b> | Çevre (mm)<br><i>Perimeter</i>         | 114 |
|                | Alan (mm <sup>2</sup> )<br><i>Area</i> | 72  |
|                | Ağırlık (gr/m)<br><i>Weight</i>        | 208 |

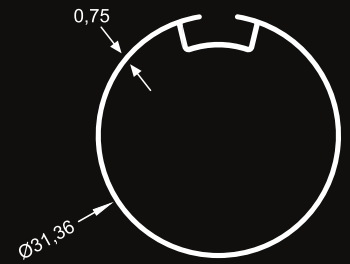

|              |  |     |
|--------------|--|-----|
| <b>10308</b> | Çevre (mm)<br><i>Perimeter</i>         | 144 |
|              | Alan (mm <sup>2</sup> )<br><i>Area</i> | 132 |
|              | Ağırlık (gr/m)<br><i>Weight</i>        | 358 |

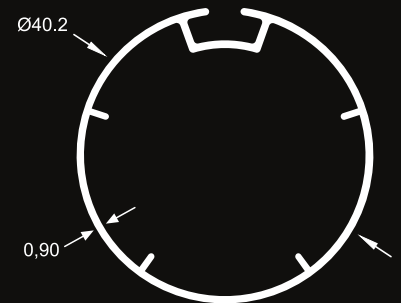



Alaşım Alüminyum

**10309**

|                                 |       |
|---------------------------------|-------|
| Çevre (mm)<br>Perimeter         | 140.4 |
| Alan (mm <sup>2</sup> )<br>Area | 128   |
| Ağırlık (gr/m)<br>Weight        | 347   |

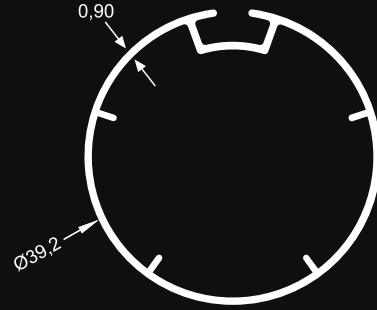

**1889**

|                                 |       |
|---------------------------------|-------|
| Çevre (mm)<br>Perimeter         | 145.8 |
| Alan (mm <sup>2</sup> )<br>Area | 181.4 |
| Ağırlık (gr/m)<br>Weight        | 491.5 |

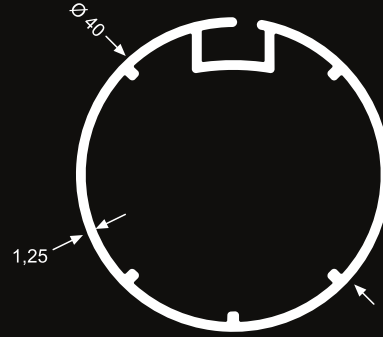

**10473**

|                                 |       |
|---------------------------------|-------|
| Çevre (mm)<br>Perimeter         | 162   |
| Alan (mm <sup>2</sup> )<br>Area | 250.6 |
| Ağırlık (gr/m)<br>Weight        | 679   |

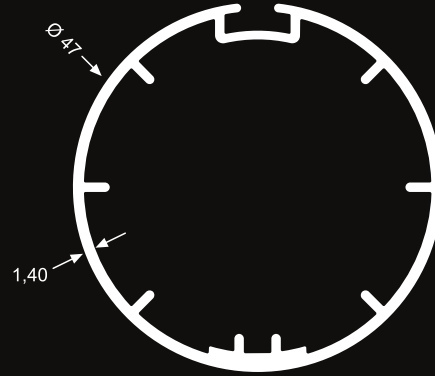

**2116**

|                                 |     |
|---------------------------------|-----|
| Çevre (mm)<br>Perimeter         | 161 |
| Alan (mm <sup>2</sup> )<br>Area | 118 |
| Ağırlık (gr/m)<br>Weight        | 322 |

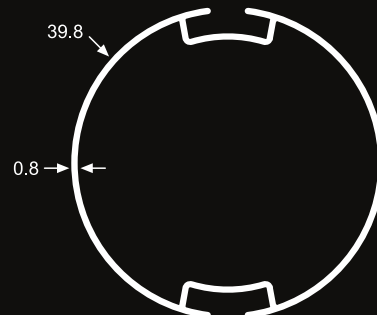

PERDE PROFİLLERİ  
BLINDS PROFILES



Alaşım Alüminyum

|             |  |       |
|-------------|--|-------|
| <b>2149</b> | Çevre (mm)<br><i>Perimeter</i>         | 120.2 |
|             | Alan (mm <sup>2</sup> )<br><i>Area</i> | 110.5 |
|             | Ağırlık (gr/m)<br><i>Weight</i>        | 300   |

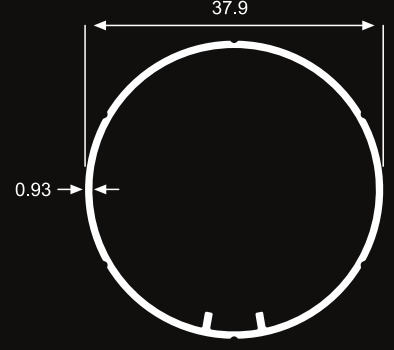

|             |  |       |
|-------------|--|-------|
| <b>2267</b> | Çevre (mm)<br><i>Perimeter</i>         | 121   |
|             | Alan (mm <sup>2</sup> )<br><i>Area</i> | 133.2 |
|             | Ağırlık (gr/m)<br><i>Weight</i>        | 361   |

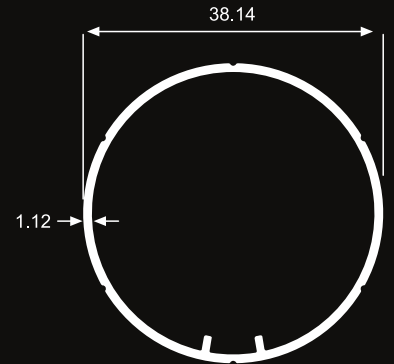



Alaşım Alüminyum

**9226**

|                                 |       |
|---------------------------------|-------|
| Çevre (mm)<br>Perimeter         | 219.6 |
| Alan (mm <sup>2</sup> )<br>Area | 304.9 |
| Ağırlık (gr/m)<br>Weight        | 826   |

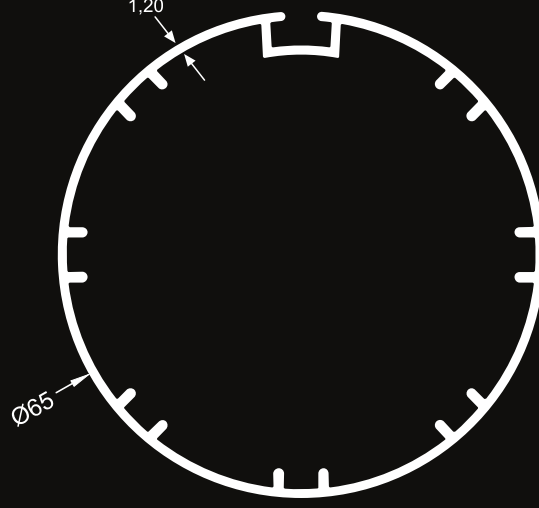

**1887**

|                                 |       |
|---------------------------------|-------|
| Çevre (mm)<br>Perimeter         | 210.4 |
| Alan (mm <sup>2</sup> )<br>Area | 653   |
| Ağırlık (gr/m)<br>Weight        | 1769  |

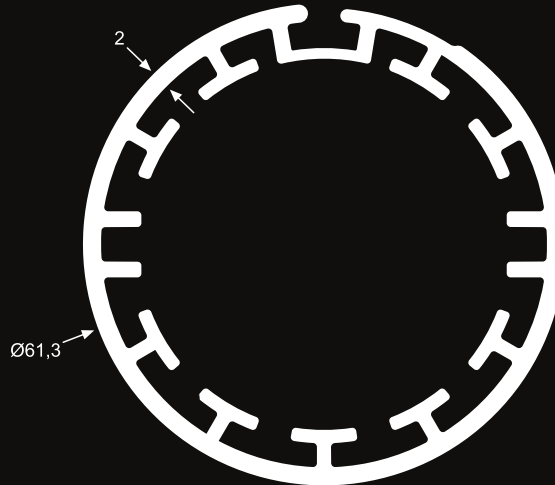

PERDE PROFİLLERİ  
BLINDS PROFILES





Alaşım Alüminyum

|              |  |     |
|--------------|--|-----|
| <b>10540</b> | Çevre (mm)<br><i>Perimeter</i>         | 401 |
|              | Alan (mm <sup>2</sup> )<br><i>Area</i> | 170 |
|              | Ağırlık (gr/m)<br><i>Weight</i>        | 461 |

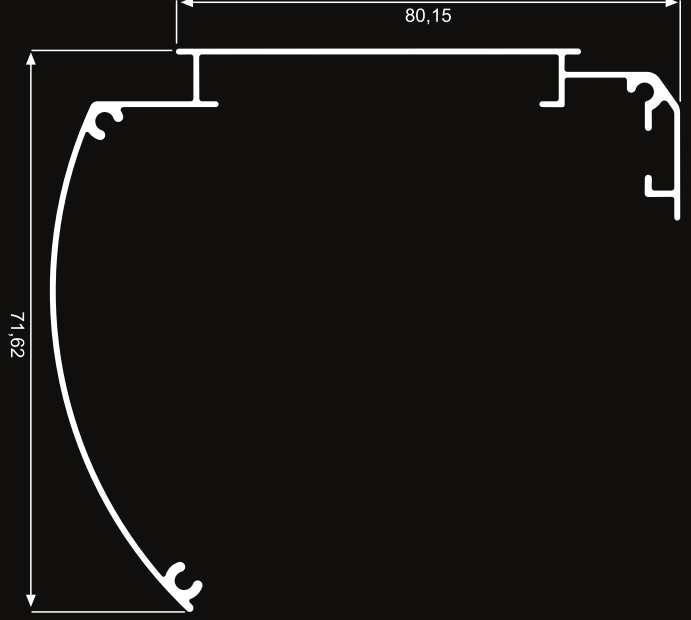

|              |  |     |
|--------------|--|-----|
| <b>10548</b> | Çevre (mm)<br><i>Perimeter</i>         | 434 |
|              | Alan (mm <sup>2</sup> )<br><i>Area</i> | 232 |
|              | Ağırlık (gr/m)<br><i>Weight</i>        | 629 |

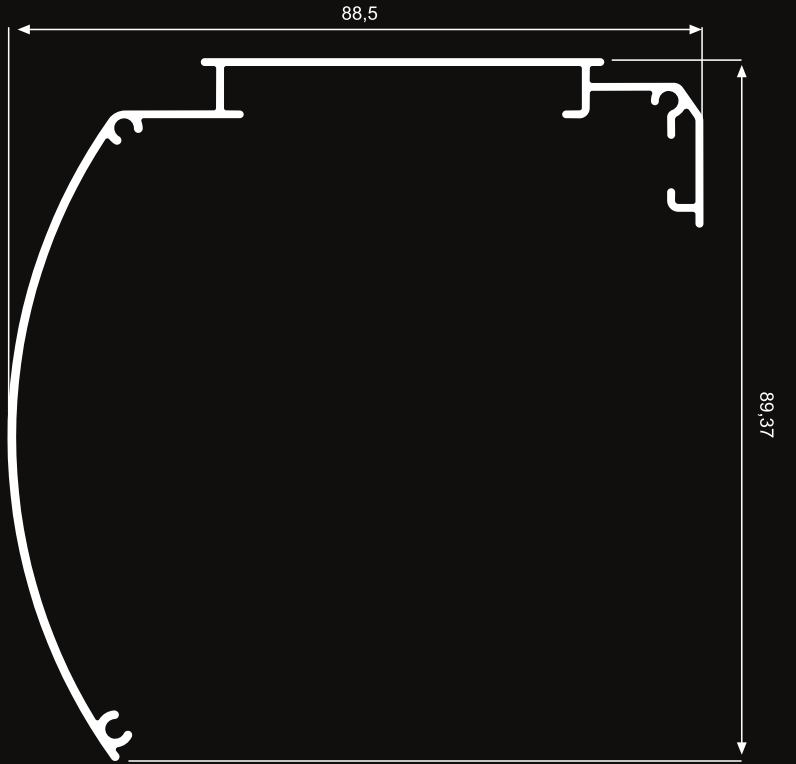



Alaşım Alüminyum

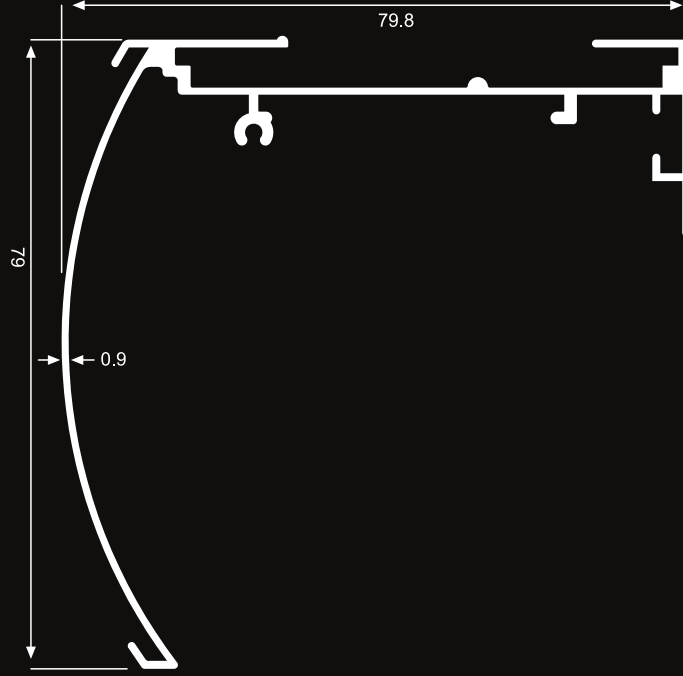

**2163**

Çevre (mm)  
Perimeter

487.8

\* Özel üründür

Alan (mm<sup>2</sup>)  
Area

256.9

Ağırlık (gr/m)  
Weight

696.3

**2165**

Çevre (mm)  
Perimeter

452

\* Özel üründür

Alan (mm<sup>2</sup>)  
Area

296.9

Ağırlık (gr/m)  
Weight

804.6

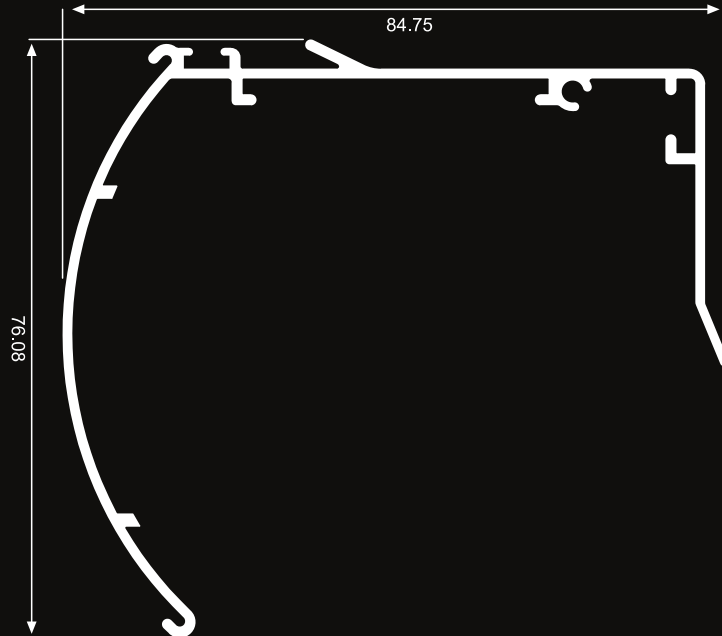

PERDE PROFİLLERİ  
BLINDS PROFILES



Alaşım Alüminyum

**2266**

\* Özel üründür

|                                 |       |
|---------------------------------|-------|
| Çevre (mm)<br>Perimeter         | 495.2 |
| Alan (mm <sup>2</sup> )<br>Area | 335.3 |
| Ağırlık (gr/m)<br>Weight        | 908   |

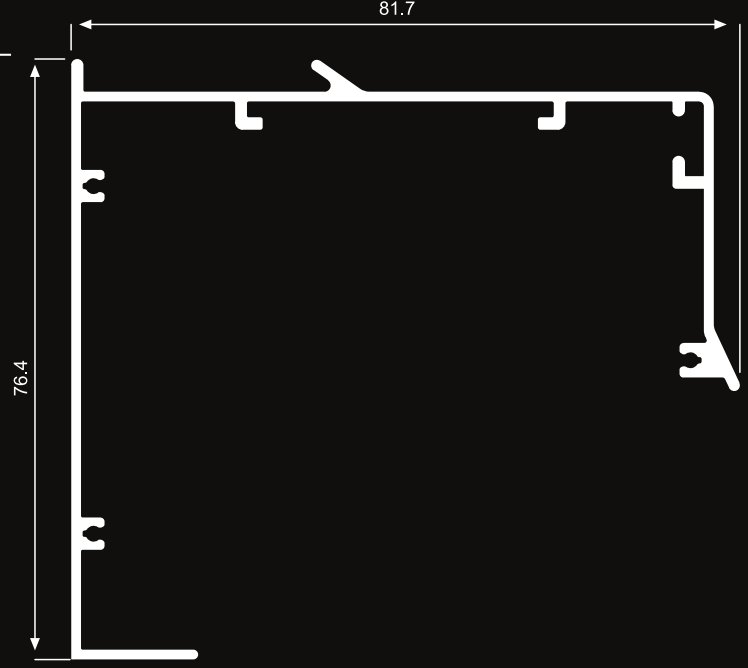

**2152**

\* Özel üründür

|                                 |       |
|---------------------------------|-------|
| Çevre (mm)<br>Perimeter         | 502.9 |
| Alan (mm <sup>2</sup> )<br>Area | 385.8 |
| Ağırlık (gr/m)<br>Weight        | 1045  |

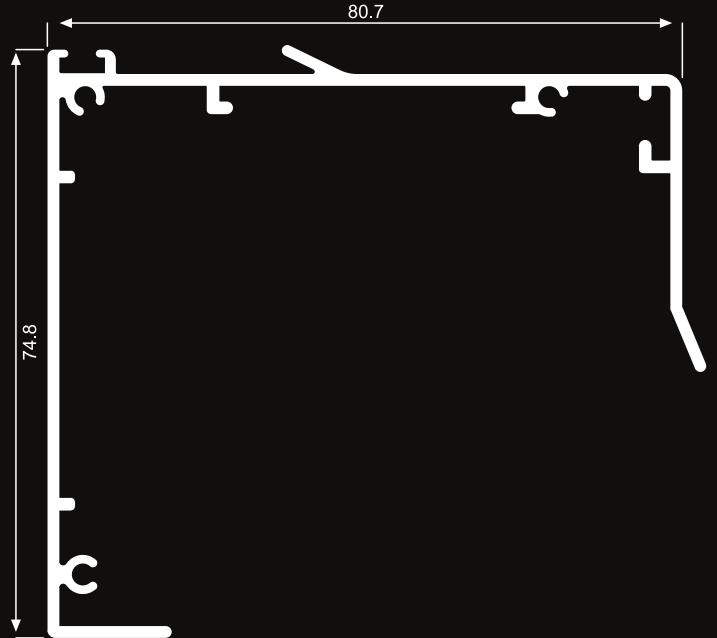



Alaşım Alüminyum

**2167**

Çevre (mm)  
Perimeter

294.9

\* Özel üründür

Alan (mm<sup>2</sup>)  
Area

183

Ağırlık (gr/m)  
Weight

496

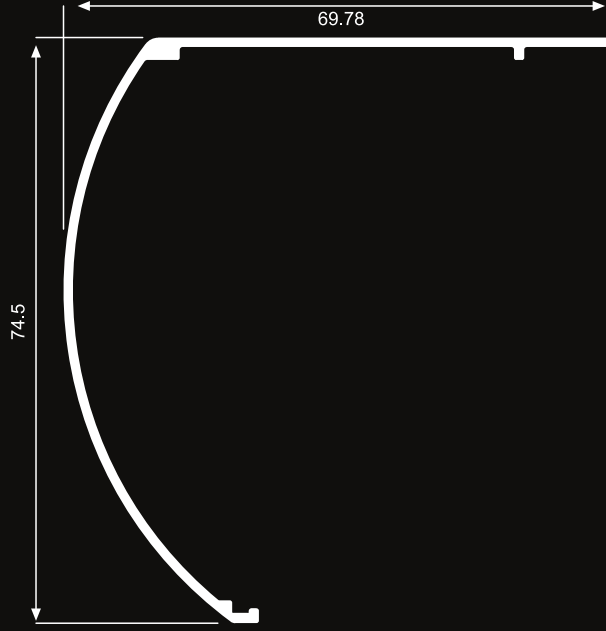

**2243**

Çevre (mm)  
Perimeter

467

Alan (mm<sup>2</sup>)  
Area

224

Ağırlık (gr/m)  
Weight

607

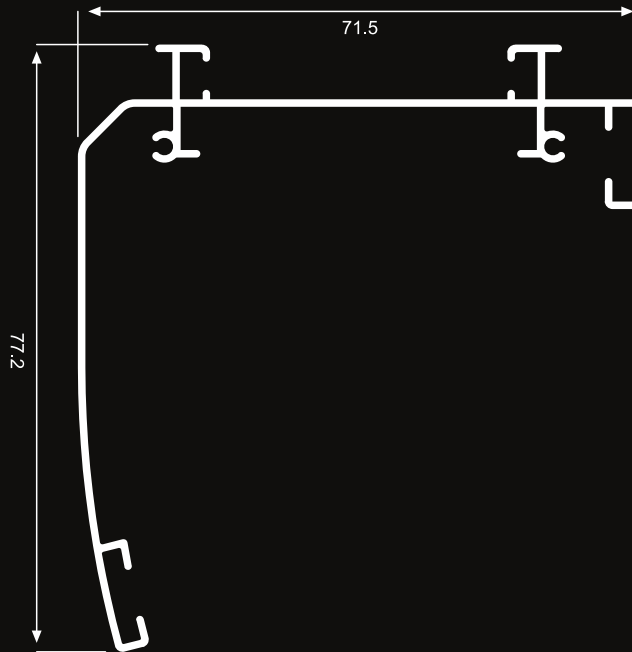

PERDE PROFİLLERİ  
BLINDS PROFILES



Alaşım Alüminyum

|             |  |        |
|-------------|--|--------|
| <b>1778</b> | Çevre (mm)<br><i>Perimeter</i>         | 368    |
|             | Alan (mm <sup>2</sup> )<br><i>Area</i> | 171.70 |
|             | Ağırlık (gr/m)<br><i>Weight</i>        | 465    |

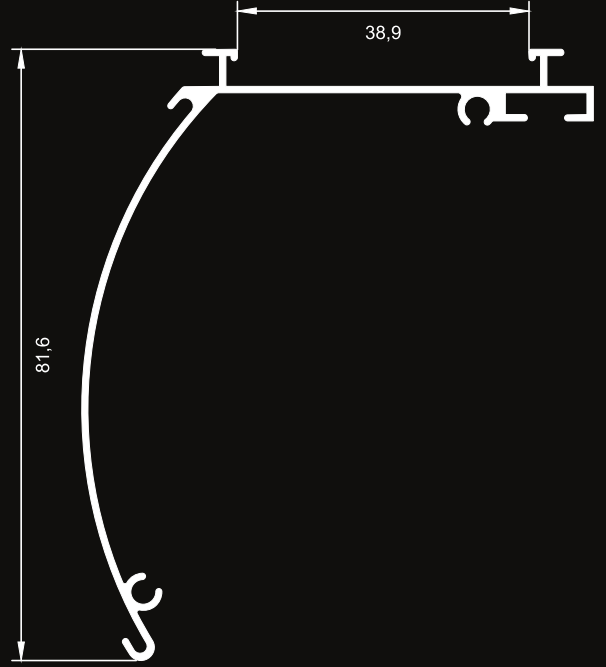

|             |  |       |
|-------------|--|-------|
| <b>1833</b> | Çevre (mm)<br><i>Perimeter</i>         | 415.2 |
|             | Alan (mm <sup>2</sup> )<br><i>Area</i> | 207.9 |
|             | Ağırlık (gr/m)<br><i>Weight</i>        | 563   |

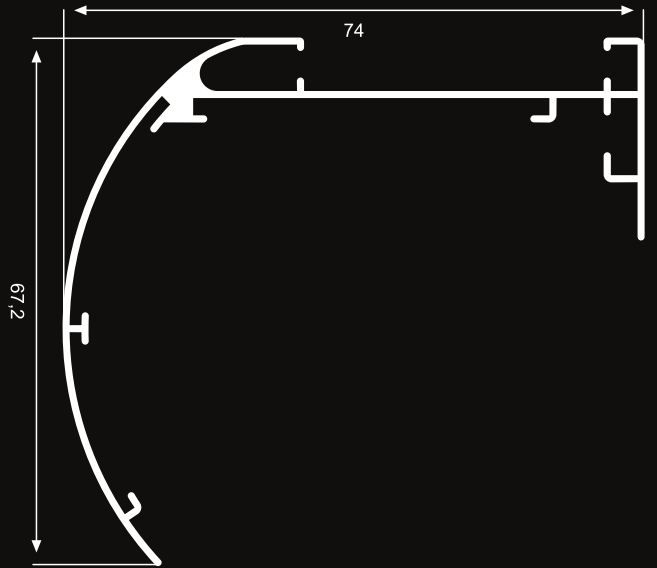



Alaşım Alüminyum

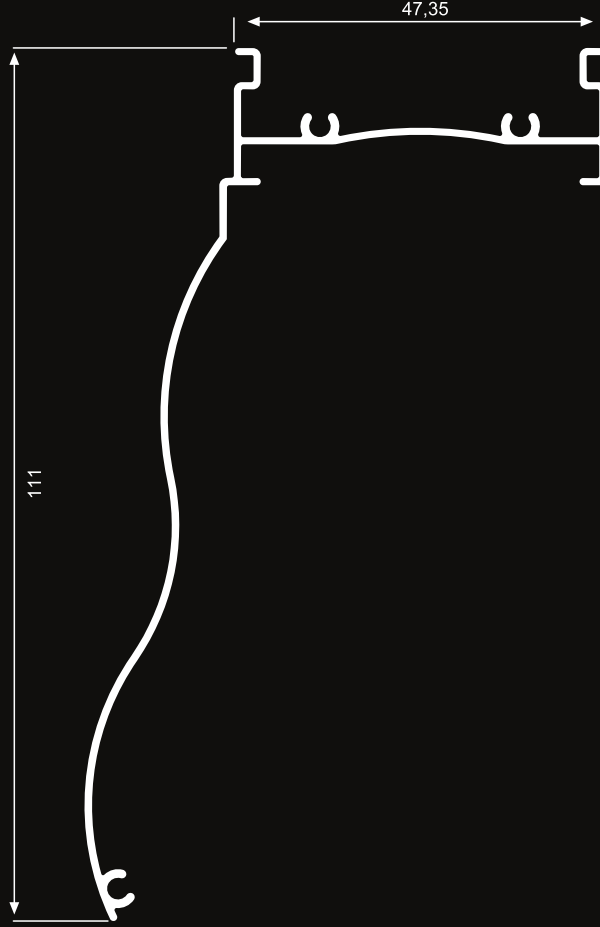

|              |                                 |     |
|--------------|---------------------------------|-----|
| <b>10760</b> | Çevre (mm)<br>Perimeter         | 416 |
|              | Alan (mm <sup>2</sup> )<br>Area | 200 |
|              | Ağırlık (gr/m)<br>Weight        | 544 |

|             |                                 |     |
|-------------|---------------------------------|-----|
| <b>1894</b> | Çevre (mm)<br>Perimeter         | 215 |
|             | Alan (mm <sup>2</sup> )<br>Area | 107 |
|             | Ağırlık (gr/m)<br>Weight        | 290 |

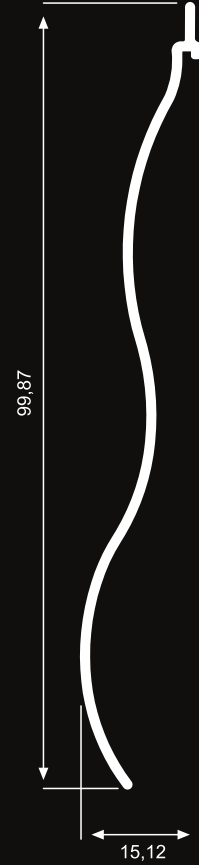

PERDE PROFİLLERİ  
BLINDS PROFILES



Alaşım Alüminyum

|             |                                 |       |
|-------------|---------------------------------|-------|
| <b>2035</b> | Çevre (mm)<br>Perimeter         | 201.8 |
|             | Alan (mm <sup>2</sup> )<br>Area | 112.9 |
|             | Ağırlık (gr/m)<br>Weight        | 305   |
|             |                                 |       |

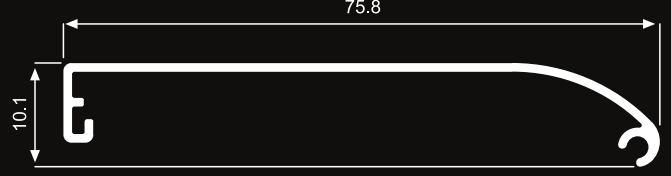

|             |                                 |       |
|-------------|---------------------------------|-------|
| <b>2037</b> | Çevre (mm)<br>Perimeter         | 337.6 |
|             | Alan (mm <sup>2</sup> )<br>Area | 185.6 |
|             | Ağırlık (gr/m)<br>Weight        | 502   |
|             |                                 |       |

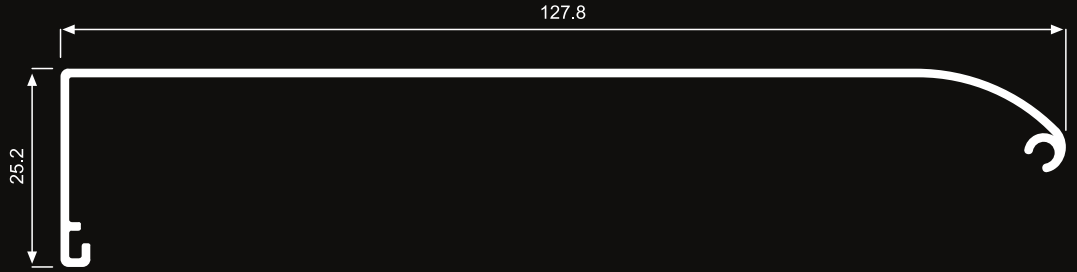

|             |                                 |       |
|-------------|---------------------------------|-------|
| <b>2038</b> | Çevre (mm)<br>Perimeter         | 246.9 |
|             | Alan (mm <sup>2</sup> )<br>Area | 143.6 |
|             | Ağırlık (gr/m)<br>Weight        | 389   |
|             |                                 |       |

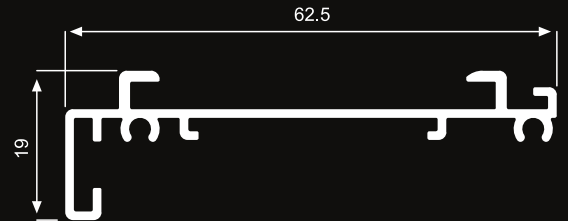



Alaşım Alüminyum

**2193**

\* Özel üründür

|                                 |       |
|---------------------------------|-------|
| Çevre (mm)<br>Perimeter         | 349.8 |
| Alan (mm <sup>2</sup> )<br>Area | 275.5 |
| Ağırlık (gr/m)<br>Weight        | 747   |

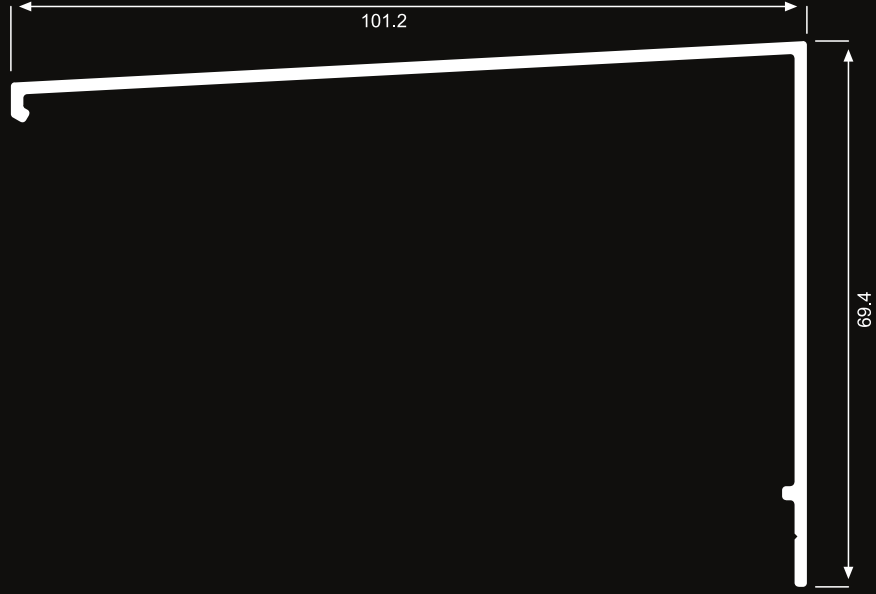

**2194**

\* Özel üründür

|                                 |       |
|---------------------------------|-------|
| Çevre (mm)<br>Perimeter         | 278.1 |
| Alan (mm <sup>2</sup> )<br>Area | 208.2 |
| Ağırlık (gr/m)<br>Weight        | 564   |



PERDE PROFİLLERİ  
BLINDS PROFILES





Alaşım Alüminyum

|              |  |     |
|--------------|--|-----|
| <b>10391</b> | Çevre (mm)<br><i>Perimeter</i>         | 176 |
|              | Alan (mm <sup>2</sup> )<br><i>Area</i> | 77  |
|              | Ağırlık (gr/m)<br><i>Weight</i>        | 209 |

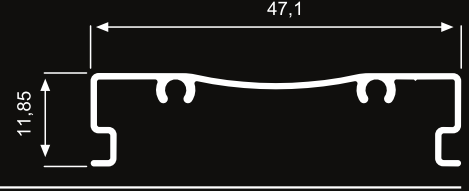

|              |  |     |
|--------------|--|-----|
| <b>10428</b> | Çevre (mm)<br><i>Perimeter</i>         | 209 |
|              | Alan (mm <sup>2</sup> )<br><i>Area</i> | 80  |
|              | Ağırlık (gr/m)<br><i>Weight</i>        | 217 |

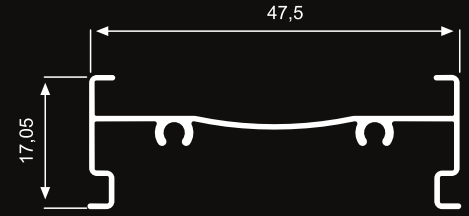

|              |  |       |
|--------------|--|-------|
| <b>10433</b> | Çevre (mm)<br><i>Perimeter</i>         | 178,2 |
|              | Alan (mm <sup>2</sup> )<br><i>Area</i> | 65,1  |
|              | Ağırlık (gr/m)<br><i>Weight</i>        | 176   |

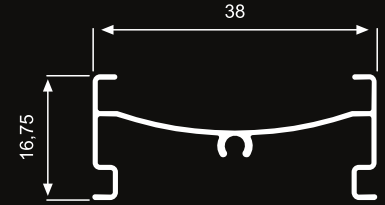

|             |  |     |
|-------------|--|-----|
| <b>9490</b> | Çevre (mm)<br><i>Perimeter</i>         | 198 |
|             | Alan (mm <sup>2</sup> )<br><i>Area</i> | 72  |
|             | Ağırlık (gr/m)<br><i>Weight</i>        | 195 |

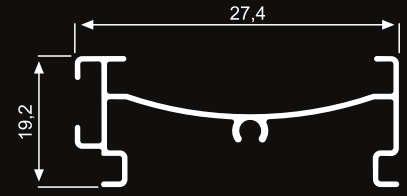

|              |  |     |
|--------------|--|-----|
| <b>10490</b> | Çevre (mm)<br><i>Perimeter</i>         | 226 |
|              | Alan (mm <sup>2</sup> )<br><i>Area</i> | 81  |
|              | Ağırlık (gr/m)<br><i>Weight</i>        | 220 |

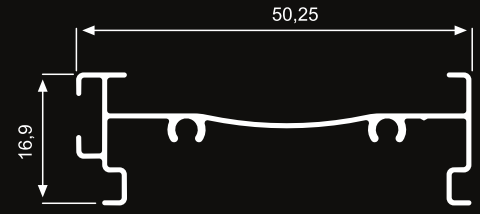



Alaşım Alüminyum

|             |                                 |    |
|-------------|---------------------------------|----|
| <b>1767</b> | Çevre (mm)<br>Perimeter         | 47 |
|             | Alan (mm <sup>2</sup> )<br>Area | 35 |
|             | Ağırlık (gr/m)<br>Weight        | 95 |



|             |                                 |     |
|-------------|---------------------------------|-----|
| <b>9516</b> | Çevre (mm)<br>Perimeter         | 43  |
|             | Alan (mm <sup>2</sup> )<br>Area | 45  |
|             | Ağırlık (gr/m)<br>Weight        | 122 |



|              |                                 |     |
|--------------|---------------------------------|-----|
| <b>10549</b> | Çevre (mm)<br>Perimeter         | 44  |
|              | Alan (mm <sup>2</sup> )<br>Area | 72  |
|              | Ağırlık (gr/m)<br>Weight        | 195 |



|             |                                 |      |
|-------------|---------------------------------|------|
| <b>2212</b> | Çevre (mm)<br>Perimeter         | 99.5 |
|             | Alan (mm <sup>2</sup> )<br>Area | 97.8 |
|             | Ağırlık (gr/m)<br>Weight        | 265  |



|             |                                 |      |
|-------------|---------------------------------|------|
| <b>2189</b> | Çevre (mm)<br>Perimeter         | 30.8 |
|             | Alan (mm <sup>2</sup> )<br>Area | 37.7 |
|             | Ağırlık (gr/m)<br>Weight        | 102  |



|             |                                 |      |
|-------------|---------------------------------|------|
| <b>2192</b> | Çevre (mm)<br>Perimeter         | 58.6 |
|             | Alan (mm <sup>2</sup> )<br>Area | 92.3 |
|             | Ağırlık (gr/m)<br>Weight        | 250  |



PERDE PROFİLLERİ  
BLINDS PROFILES



Alaşım Alüminyum

|             |                                 |       |
|-------------|---------------------------------|-------|
| <b>2190</b> | Çevre (mm)<br>Perimeter         | 100.5 |
|             | Alan (mm <sup>2</sup> )<br>Area | 86.1  |
|             | Ağırlık (gr/m)<br>Weight        | 233   |

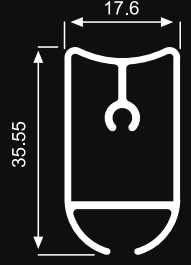

|              |                                 |      |
|--------------|---------------------------------|------|
| <b>10542</b> | Çevre (mm)<br>Perimeter         | 75.8 |
|              | Alan (mm <sup>2</sup> )<br>Area | 81.3 |
|              | Ağırlık (gr/m)<br>Weight        | 220  |

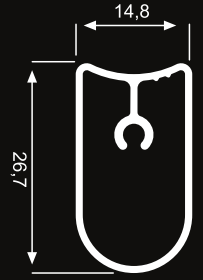

|             |                                 |     |
|-------------|---------------------------------|-----|
| <b>9664</b> | Çevre (mm)<br>Perimeter         | 92  |
|             | Alan (mm <sup>2</sup> )<br>Area | 65  |
|             | Ağırlık (gr/m)<br>Weight        | 176 |

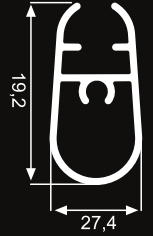

|             |                                 |     |
|-------------|---------------------------------|-----|
| <b>2097</b> | Çevre (mm)<br>Perimeter         | 62  |
|             | Alan (mm <sup>2</sup> )<br>Area | 69  |
|             | Ağırlık (gr/m)<br>Weight        | 187 |

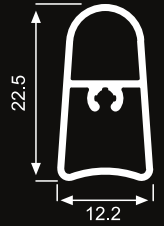

|              |                                 |     |
|--------------|---------------------------------|-----|
| <b>10443</b> | Çevre (mm)<br>Perimeter         | 65  |
|              | Alan (mm <sup>2</sup> )<br>Area | 62  |
|              | Ağırlık (gr/m)<br>Weight        | 168 |

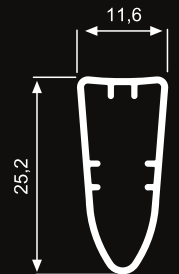



Alaşım Alüminyum

|             |                                 |     |
|-------------|---------------------------------|-----|
| <b>1834</b> | Çevre (mm)<br>Perimeter         | 115 |
|             | Alan (mm <sup>2</sup> )<br>Area | 111 |
|             | Ağırlık (gr/m)<br>Weight        | 301 |

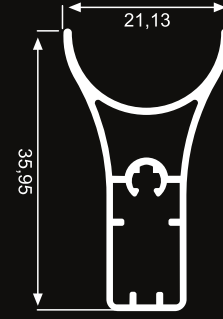

|             |                                 |       |
|-------------|---------------------------------|-------|
| <b>1906</b> | Çevre (mm)<br>Perimeter         | 158.7 |
|             | Alan (mm <sup>2</sup> )<br>Area | 147.8 |
|             | Ağırlık (gr/m)<br>Weight        | 400   |

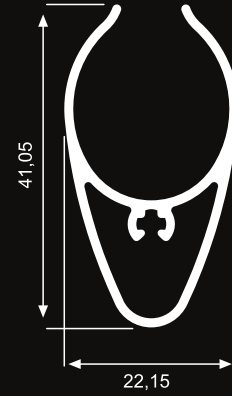

|              |                                 |       |
|--------------|---------------------------------|-------|
| <b>10471</b> | Çevre (mm)<br>Perimeter         | 118.9 |
|              | Alan (mm <sup>2</sup> )<br>Area | 67.8  |
|              | Ağırlık (gr/m)<br>Weight        | 183   |

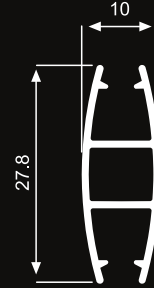

|             |                                 |       |
|-------------|---------------------------------|-------|
| <b>2032</b> | Çevre (mm)<br>Perimeter         | 106.5 |
|             | Alan (mm <sup>2</sup> )<br>Area | 112.7 |
|             | Ağırlık (gr/m)<br>Weight        | 306   |

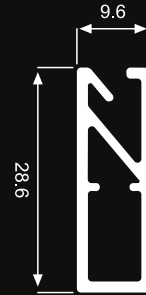

|             |                                 |       |
|-------------|---------------------------------|-------|
| <b>2036</b> | Çevre (mm)<br>Perimeter         | 165   |
|             | Alan (mm <sup>2</sup> )<br>Area | 162.1 |
|             | Ağırlık (gr/m)<br>Weight        | 439   |

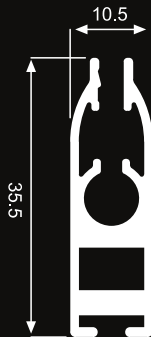

|             |                                 |       |
|-------------|---------------------------------|-------|
| <b>2166</b> | Çevre (mm)<br>Perimeter         | 163.3 |
|             | Alan (mm <sup>2</sup> )<br>Area | 135.1 |
|             | Ağırlık (gr/m)<br>Weight        | 366.1 |



PERDE PROFİLLERİ  
BLINDS PROFILES



Alaşım Alüminyum

|             |  |     |
|-------------|--|-----|
| <b>2045</b> | Çevre (mm)<br><i>Perimeter</i>         | 216 |
|             | Alan (mm <sup>2</sup> )<br><i>Area</i> | 162 |
|             | Ağırlık (gr/m)<br><i>Weight</i>        | 439 |

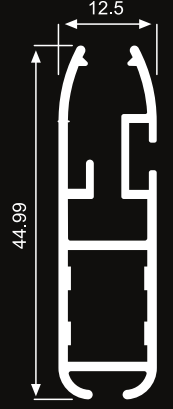

|             |  |       |
|-------------|--|-------|
| <b>2050</b> | Çevre (mm)<br><i>Perimeter</i>         | 95.47 |
|             | Alan (mm <sup>2</sup> )<br><i>Area</i> | 84    |
|             | Ağırlık (gr/m)<br><i>Weight</i>        | 277   |



|             |  |       |
|-------------|--|-------|
| <b>2162</b> | Çevre (mm)<br><i>Perimeter</i>         | 157.4 |
|             | Alan (mm <sup>2</sup> )<br><i>Area</i> | 82.9  |
|             | Ağırlık (gr/m)<br><i>Weight</i>        | 224.7 |

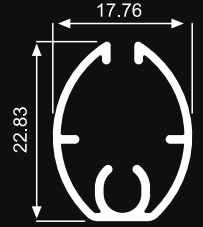

|             |  |       |
|-------------|--|-------|
| <b>2164</b> | Çevre (mm)<br><i>Perimeter</i>         | 235   |
|             | Alan (mm <sup>2</sup> )<br><i>Area</i> | 146.1 |
|             | Ağırlık (gr/m)<br><i>Weight</i>        | 395.9 |

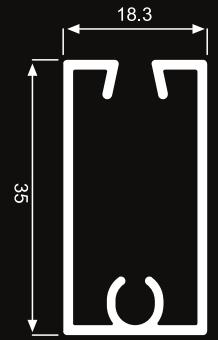

|             |  |       |
|-------------|--|-------|
| <b>2191</b> | Çevre (mm)<br><i>Perimeter</i>         | 197.8 |
|             | Alan (mm <sup>2</sup> )<br><i>Area</i> | 124.5 |
|             | Ağırlık (gr/m)<br><i>Weight</i>        | 337   |

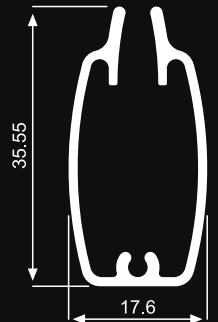



Alaşım Alüminyum

|             |                                 |      |
|-------------|---------------------------------|------|
| <b>1810</b> | Çevre (mm)<br>Perimeter         | 58.1 |
|             | Alan (mm <sup>2</sup> )<br>Area | 40   |
|             | Ağırlık (gr/m)<br>Weight        | 108  |



|             |                                 |     |
|-------------|---------------------------------|-----|
| <b>1811</b> | Çevre (mm)<br>Perimeter         | 94  |
|             | Alan (mm <sup>2</sup> )<br>Area | 51  |
|             | Ağırlık (gr/m)<br>Weight        | 138 |

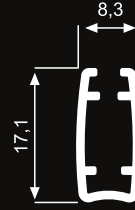

|             |                                 |       |
|-------------|---------------------------------|-------|
| <b>2043</b> | Çevre (mm)<br>Perimeter         | 238.4 |
|             | Alan (mm <sup>2</sup> )<br>Area | 124   |
|             | Ağırlık (gr/m)<br>Weight        | 336   |

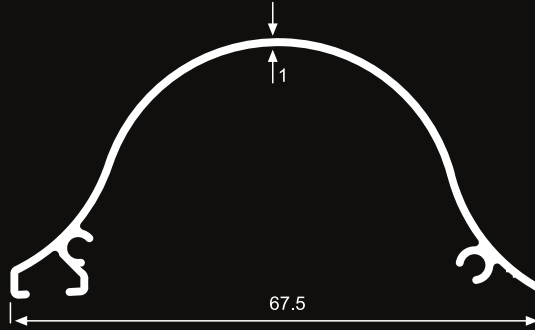

|             |                                 |     |
|-------------|---------------------------------|-----|
| <b>1813</b> | Çevre (mm)<br>Perimeter         | 241 |
|             | Alan (mm <sup>2</sup> )<br>Area | 113 |
|             | Ağırlık (gr/m)<br>Weight        | 306 |

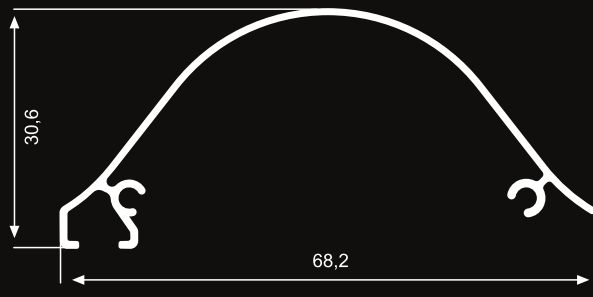

PERDE PROFİLLERİ  
BLINDS PROFILES



Alaşım Alüminyum

|             |                                 |     |
|-------------|---------------------------------|-----|
| <b>1812</b> | Çevre (mm)<br>Perimeter         | 72  |
|             | Alan (mm <sup>2</sup> )<br>Area | 50  |
|             | Ağırlık (gr/m)<br>Weight        | 136 |



|             |                                 |    |
|-------------|---------------------------------|----|
| <b>2399</b> | Çevre (mm)<br>Perimeter         | 65 |
|             | Alan (mm <sup>2</sup> )<br>Area | 32 |
|             | Ağırlık (gr/m)<br>Weight        | 87 |

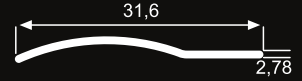

|             |                                 |       |
|-------------|---------------------------------|-------|
| <b>2044</b> | Çevre (mm)<br>Perimeter         | 109.4 |
|             | Alan (mm <sup>2</sup> )<br>Area | 53.9  |
|             | Ağırlık (gr/m)<br>Weight        | 146   |

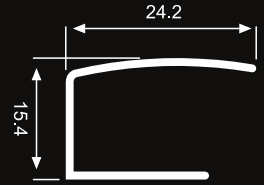

|             |                                 |      |
|-------------|---------------------------------|------|
| <b>1814</b> | Çevre (mm)<br>Perimeter         | 37.7 |
|             | Alan (mm <sup>2</sup> )<br>Area | 18.9 |
|             | Ağırlık (gr/m)<br>Weight        | 51   |



|             |                                 |     |
|-------------|---------------------------------|-----|
| <b>1815</b> | Çevre (mm)<br>Perimeter         | 70  |
|             | Alan (mm <sup>2</sup> )<br>Area | 37  |
|             | Ağırlık (gr/m)<br>Weight        | 100 |

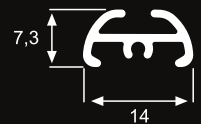



Alaşım Alüminyum

|             |                                 |      |
|-------------|---------------------------------|------|
| <b>1808</b> | Çevre (mm)<br>Perimeter         | 26.1 |
|             | Alan (mm <sup>2</sup> )<br>Area | 26.8 |
|             | Ağırlık (gr/m)<br>Weight        | 72   |

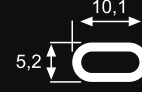

|             |                                 |      |
|-------------|---------------------------------|------|
| <b>1809</b> | Çevre (mm)<br>Perimeter         | 16.9 |
|             | Alan (mm <sup>2</sup> )<br>Area | 16.2 |
|             | Ağırlık (gr/m)<br>Weight        | 44   |

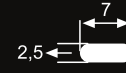

|             |                                 |      |
|-------------|---------------------------------|------|
| <b>1761</b> | Çevre (mm)<br>Perimeter         | 28   |
|             | Alan (mm <sup>2</sup> )<br>Area | 27.3 |
|             | Ağırlık (gr/m)<br>Weight        | 74   |



|             |                                 |      |
|-------------|---------------------------------|------|
| <b>1762</b> | Çevre (mm)<br>Perimeter         | 20.4 |
|             | Alan (mm <sup>2</sup> )<br>Area | 18.6 |
|             | Ağırlık (gr/m)<br>Weight        | 50   |



|             |                                 |      |
|-------------|---------------------------------|------|
| <b>2094</b> | Çevre (mm)<br>Perimeter         | 31.4 |
|             | Alan (mm <sup>2</sup> )<br>Area | 28.3 |
|             | Ağırlık (gr/m)<br>Weight        | 76   |



|             |                                 |       |
|-------------|---------------------------------|-------|
| <b>2121</b> | Çevre (mm)<br>Perimeter         | 22    |
|             | Alan (mm <sup>2</sup> )<br>Area | 18.85 |
|             | Ağırlık (gr/m)<br>Weight        | 51.1  |

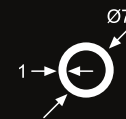

PERDE PROFİLLERİ  
BLINDS PROFILES





Alaşım Alüminyum

|             |                                 |       |
|-------------|---------------------------------|-------|
| <b>1700</b> | Çevre (mm)<br>Perimeter         | 229.5 |
|             | Alan (mm <sup>2</sup> )<br>Area | 119.7 |
|             | Ağırlık (gr/m)<br>Weight        | 0.324 |

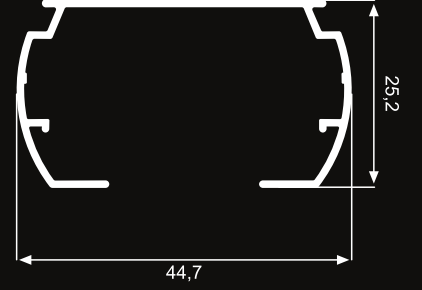

|              |                                 |       |
|--------------|---------------------------------|-------|
| <b>10448</b> | Çevre (mm)<br>Perimeter         | 275.9 |
|              | Alan (mm <sup>2</sup> )<br>Area | 121.4 |
|              | Ağırlık (gr/m)<br>Weight        | 329   |

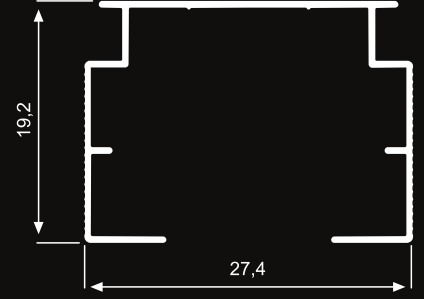

|             |                                 |      |
|-------------|---------------------------------|------|
| <b>1802</b> | Çevre (mm)<br>Perimeter         | 19.6 |
|             | Alan (mm <sup>2</sup> )<br>Area | 22.6 |
|             | Ağırlık (gr/m)<br>Weight        | 0.63 |



|             |                                 |      |
|-------------|---------------------------------|------|
| <b>2444</b> | Çevre (mm)<br>Perimeter         | 18,6 |
|             | Alan (mm <sup>2</sup> )<br>Area | 18,2 |
|             | Ağırlık (gr/m)<br>Weight        | 49   |

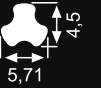

|             |                                 |      |
|-------------|---------------------------------|------|
| <b>2346</b> | Çevre (mm)<br>Perimeter         | 19,4 |
|             | Alan (mm <sup>2</sup> )<br>Area | 18,3 |
|             | Ağırlık (gr/m)<br>Weight        | 49   |





Alaşım Alüminyum

|             |  |       |
|-------------|--|-------|
| <b>1870</b> | Çevre (mm)<br><i>Perimeter</i>         | 148.1 |
|             | Alan (mm <sup>2</sup> )<br><i>Area</i> | 78.5  |
|             | Ağırlık (gr/m)<br><i>Weight</i>        | 212   |

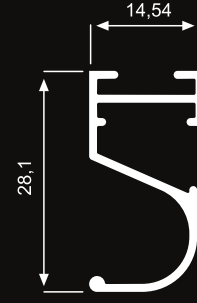

|             |  |     |
|-------------|--|-----|
| <b>1807</b> | Çevre (mm)<br><i>Perimeter</i>         | 131 |
|             | Alan (mm <sup>2</sup> )<br><i>Area</i> | 56  |
|             | Ağırlık (gr/m)<br><i>Weight</i>        | 152 |

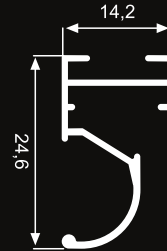

|             |  |     |
|-------------|--|-----|
| <b>1844</b> | Çevre (mm)<br><i>Perimeter</i>         | 138 |
|             | Alan (mm <sup>2</sup> )<br><i>Area</i> | 75  |
|             | Ağırlık (gr/m)<br><i>Weight</i>        | 203 |

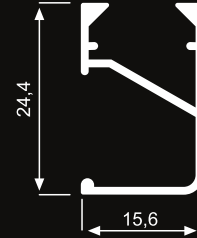

|             |  |    |
|-------------|--|----|
| <b>1845</b> | Çevre (mm)<br><i>Perimeter</i>         | 39 |
|             | Alan (mm <sup>2</sup> )<br><i>Area</i> | 18 |
|             | Ağırlık (gr/m)<br><i>Weight</i>        | 50 |

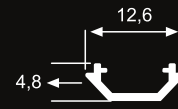

|             |  |       |
|-------------|--|-------|
| <b>2051</b> | Çevre (mm)<br><i>Perimeter</i>         | 137.8 |
|             | Alan (mm <sup>2</sup> )<br><i>Area</i> | 76    |
|             | Ağırlık (gr/m)<br><i>Weight</i>        | 206   |

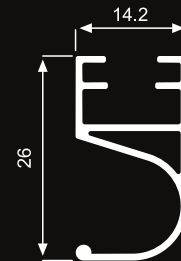

|             |  |      |
|-------------|--|------|
| <b>2160</b> | Çevre (mm)<br><i>Perimeter</i>         | 51.4 |
|             | Alan (mm <sup>2</sup> )<br><i>Area</i> | 43.4 |
|             | Ağırlık (gr/m)<br><i>Weight</i>        | 118  |

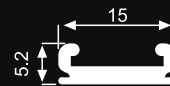

PERDE PROFİLLERİ  
BLINDS PROFILES



Alaşım Alüminyum

|             |  |     |
|-------------|--|-----|
| <b>2310</b> | Çevre (mm)<br><i>Perimeter</i>         | 83  |
|             | Alan (mm <sup>2</sup> )<br><i>Area</i> | 37  |
|             | Ağırlık (gr/m)<br><i>Weight</i>        | 100 |

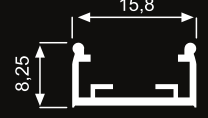

|             |  |       |
|-------------|--|-------|
| <b>2311</b> | Çevre (mm)<br><i>Perimeter</i>         | 106,2 |
|             | Alan (mm <sup>2</sup> )<br><i>Area</i> | 78,6  |
|             | Ağırlık (gr/m)<br><i>Weight</i>        | 213   |

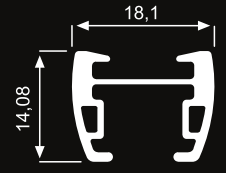

|             |  |      |
|-------------|--|------|
| <b>2356</b> | Çevre (mm)<br><i>Perimeter</i>         | 97,8 |
|             | Alan (mm <sup>2</sup> )<br><i>Area</i> | 41,2 |
|             | Ağırlık (gr/m)<br><i>Weight</i>        | 111  |

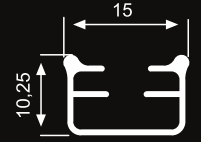

|             |  |      |
|-------------|--|------|
| <b>2422</b> | Çevre (mm)<br><i>Perimeter</i>         | 64,9 |
|             | Alan (mm <sup>2</sup> )<br><i>Area</i> | 35,8 |
|             | Ağırlık (gr/m)<br><i>Weight</i>        | 97   |

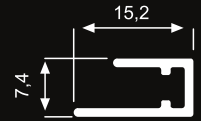

|             |  |      |
|-------------|--|------|
| <b>2122</b> | Çevre (mm)<br><i>Perimeter</i>         | 146  |
|             | Alan (mm <sup>2</sup> )<br><i>Area</i> | 57,5 |
|             | Ağırlık (gr/m)<br><i>Weight</i>        | 156  |

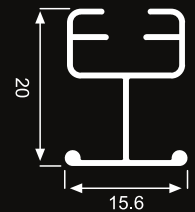



Alaşım Alüminyum

**2279**

|                                 |     |
|---------------------------------|-----|
| Çevre (mm)<br>Perimeter         | 115 |
| Alan (mm <sup>2</sup> )<br>Area | 94  |
| Ağırlık (gr/m)<br>Weight        | 255 |

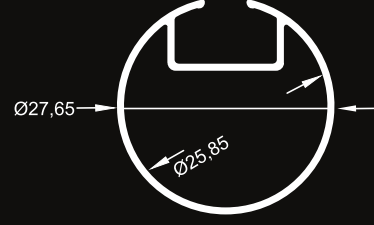

**2294**

|                                 |       |
|---------------------------------|-------|
| Çevre (mm)<br>Perimeter         | 139,8 |
| Alan (mm <sup>2</sup> )<br>Area | 191,4 |
| Ağırlık (gr/m)<br>Weight        | 518   |

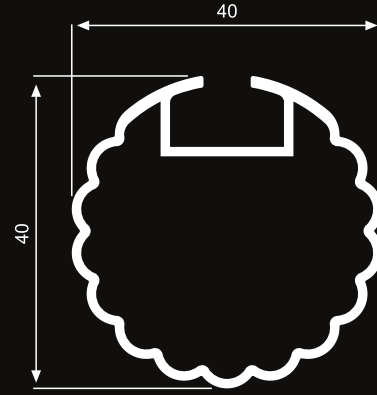

**2093**

|                                 |       |
|---------------------------------|-------|
| Çevre (mm)<br>Perimeter         | 346.5 |
| Alan (mm <sup>2</sup> )<br>Area | 193.7 |
| Ağırlık (gr/m)<br>Weight        | 525   |

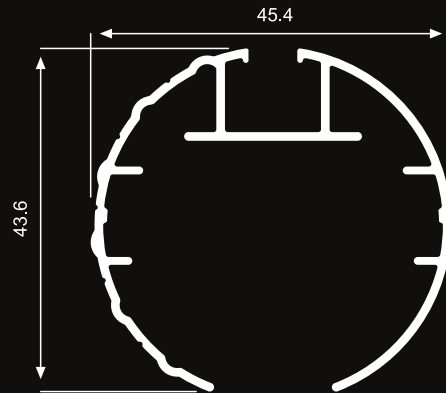

PERDE PROFİLLERİ  
BLINDS PROFILES



Alaşım Alüminyum

|             |  |     |
|-------------|--|-----|
| <b>1819</b> | Çevre (mm)<br><i>Perimeter</i>         | 99  |
|             | Alan (mm <sup>2</sup> )<br><i>Area</i> | 57  |
|             | Ağırlık (gr/m)<br><i>Weight</i>        | 154 |

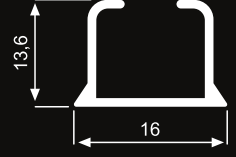

|             |  |       |
|-------------|--|-------|
| <b>2150</b> | Çevre (mm)<br><i>Perimeter</i>         | 223.9 |
|             | Alan (mm <sup>2</sup> )<br><i>Area</i> | 136   |
|             | Ağırlık (gr/m)<br><i>Weight</i>        | 369   |



|             |  |       |
|-------------|--|-------|
| <b>2151</b> | Çevre (mm)<br><i>Perimeter</i>         | 234.4 |
|             | Alan (mm <sup>2</sup> )<br><i>Area</i> | 231   |
|             | Ağırlık (gr/m)<br><i>Weight</i>        | 626   |

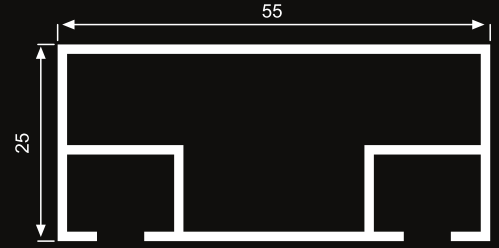

|             |  |       |
|-------------|--|-------|
| <b>2029</b> | Çevre (mm)<br><i>Perimeter</i>         | 221.5 |
|             | Alan (mm <sup>2</sup> )<br><i>Area</i> | 160.1 |
|             | Ağırlık (gr/m)<br><i>Weight</i>        | 434   |

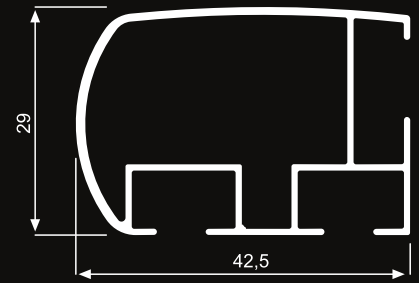



Alaşım Alüminyum

|             |  |     |
|-------------|--|-----|
| <b>1804</b> | Çevre (mm)<br><i>Perimeter</i>         | 135 |
|             | Alan (mm <sup>2</sup> )<br><i>Area</i> | 63  |
|             | Ağırlık (gr/m)<br><i>Weight</i>        | 171 |

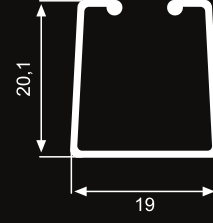

|             |  |      |
|-------------|--|------|
| <b>2211</b> | Çevre (mm)<br><i>Perimeter</i>         | 99.5 |
|             | Alan (mm <sup>2</sup> )<br><i>Area</i> | 97.8 |
|             | Ağırlık (gr/m)<br><i>Weight</i>        | 265  |

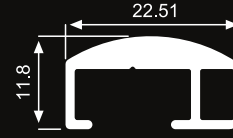

|             |  |      |
|-------------|--|------|
| <b>1805</b> | Çevre (mm)<br><i>Perimeter</i>         | 88   |
|             | Alan (mm <sup>2</sup> )<br><i>Area</i> | 84.8 |
|             | Ağırlık (gr/m)<br><i>Weight</i>        | 230  |

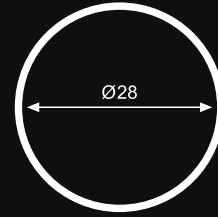

|             |  |       |
|-------------|--|-------|
| <b>1806</b> | Çevre (mm)<br><i>Perimeter</i>         | 118.8 |
|             | Alan (mm <sup>2</sup> )<br><i>Area</i> | 147   |
|             | Ağırlık (gr/m)<br><i>Weight</i>        | 398   |

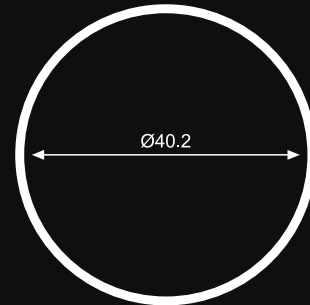

PERDE PROFİLLERİ  
BLINDS PROFILES



Alaşım Alüminyum

**1824**

|                                 |       |
|---------------------------------|-------|
| Çevre (mm)<br>Perimeter         | 287.7 |
| Alan (mm <sup>2</sup> )<br>Area | 171.6 |
| Ağırlık (gr/m)<br>Weight        | 465   |

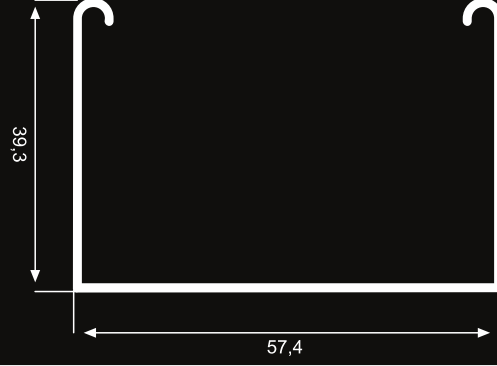

**1867**

|                                 |       |
|---------------------------------|-------|
| Çevre (mm)<br>Perimeter         | 409.4 |
| Alan (mm <sup>2</sup> )<br>Area | 235.9 |
| Ağırlık (gr/m)<br>Weight        | 639   |

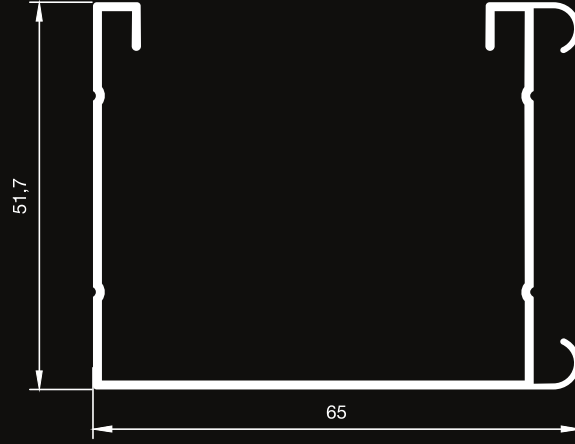

**2213**

|                                 |       |
|---------------------------------|-------|
| Çevre (mm)<br>Perimeter         | 409.5 |
| Alan (mm <sup>2</sup> )<br>Area | 223.5 |
| Ağırlık (gr/m)<br>Weight        | 434   |

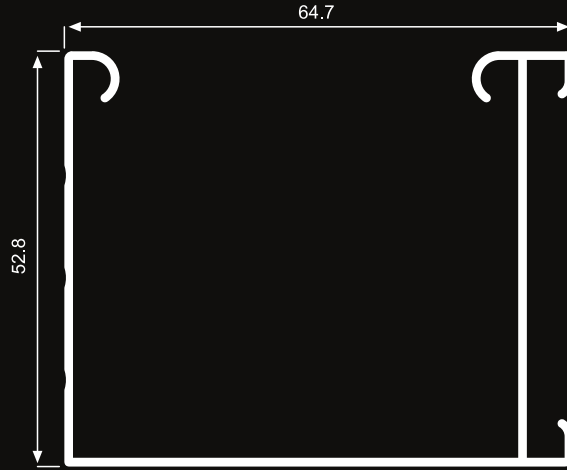

**1891**

|                                 |      |
|---------------------------------|------|
| Çevre (mm)<br>Perimeter         | 157  |
| Alan (mm <sup>2</sup> )<br>Area | 92   |
| Ağırlık (gr/m)<br>Weight        | 24.9 |

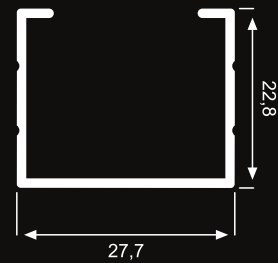

PERDE PROFİLLERİ  
BLINDS PROFILES



Alaşım Alüminyum

|             |  |       |
|-------------|--|-------|
| <b>1775</b> | Çevre (mm)<br><i>Perimeter</i>         | 164.7 |
|             | Alan (mm <sup>2</sup> )<br><i>Area</i> | 65.4  |
|             | Ağırlık (gr/m)<br><i>Weight</i>        | 177   |

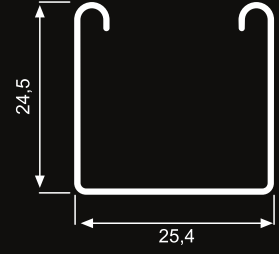

|             |  |       |
|-------------|--|-------|
| <b>1777</b> | Çevre (mm)<br><i>Perimeter</i>         | 145.4 |
|             | Alan (mm <sup>2</sup> )<br><i>Area</i> | 57.6  |
|             | Ağırlık (gr/m)<br><i>Weight</i>        | 156   |

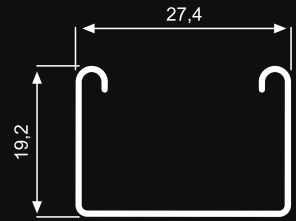

|             |  |      |
|-------------|--|------|
| <b>1776</b> | Çevre (mm)<br><i>Perimeter</i>         | 82   |
|             | Alan (mm <sup>2</sup> )<br><i>Area</i> | 32.3 |
|             | Ağırlık (gr/m)<br><i>Weight</i>        | 87   |

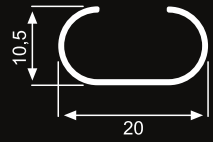

|             |  |       |
|-------------|--|-------|
| <b>1825</b> | Çevre (mm)<br><i>Perimeter</i>         | 128.9 |
|             | Alan (mm <sup>2</sup> )<br><i>Area</i> | 123.9 |
|             | Ağırlık (gr/m)<br><i>Weight</i>        | 335   |



|             |  |      |
|-------------|--|------|
| <b>2353</b> | Çevre (mm)<br><i>Perimeter</i>         | 79,5 |
|             | Alan (mm <sup>2</sup> )<br><i>Area</i> | 76,3 |
|             | Ağırlık (gr/m)<br><i>Weight</i>        | 206  |

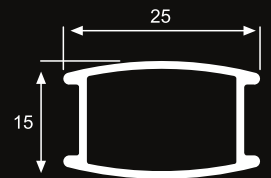





Alaşım Alüminyum

**2030**

|                                 |       |
|---------------------------------|-------|
| Çevre (mm)<br>Perimeter         | 131.8 |
| Alan (mm <sup>2</sup> )<br>Area | 116.1 |
| Ağırlık (gr/m)<br>Weight        | 314   |

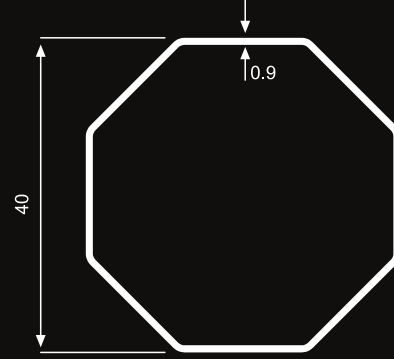

**1888**

|                                 |       |
|---------------------------------|-------|
| Çevre (mm)<br>Perimeter         | 414.6 |
| Alan (mm <sup>2</sup> )<br>Area | 296.8 |
| Ağırlık (gr/m)<br>Weight        | 804   |

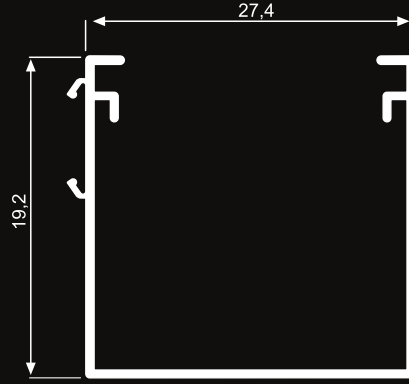

**1893**

|                                 |       |
|---------------------------------|-------|
| Çevre (mm)<br>Perimeter         | 283.2 |
| Alan (mm <sup>2</sup> )<br>Area | 125   |
| Ağırlık (gr/m)<br>Weight        | 338   |

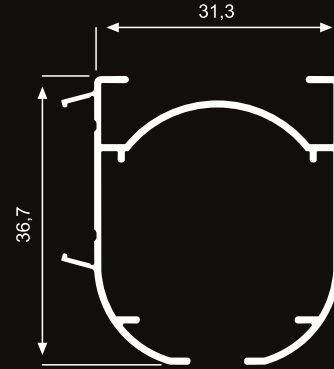

**10380**

|                                 |     |
|---------------------------------|-----|
| Çevre (mm)<br>Perimeter         | 62  |
| Alan (mm <sup>2</sup> )<br>Area | 45  |
| Ağırlık (gr/m)<br>Weight        | 122 |



**10168**

|                                 |       |
|---------------------------------|-------|
| Çevre (mm)<br>Perimeter         | 75.4  |
| Alan (mm <sup>2</sup> )<br>Area | 138.2 |
| Ağırlık (gr/m)<br>Weight        | 374   |

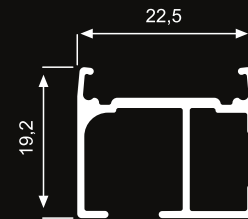

PERDE PROFİLLERİ  
BLINDS PROFILES



Alaşım Alüminyum

|             |  |     |
|-------------|--|-----|
| <b>1910</b> | Çevre (mm)<br><i>Perimeter</i>         | 25  |
|             | Alan (mm <sup>2</sup> )<br><i>Area</i> | 40  |
|             | Ağırlık (gr/m)<br><i>Weight</i>        | 108 |

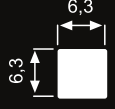

|             |  |      |
|-------------|--|------|
| <b>2361</b> | Çevre (mm)<br><i>Perimeter</i>         | 20,3 |
|             | Alan (mm <sup>2</sup> )<br><i>Area</i> | 24,6 |
|             | Ağırlık (gr/m)<br><i>Weight</i>        | 66   |



|             |  |      |
|-------------|--|------|
| <b>1814</b> | Çevre (mm)<br><i>Perimeter</i>         | 37,7 |
|             | Alan (mm <sup>2</sup> )<br><i>Area</i> | 18,9 |
|             | Ağırlık (gr/m)<br><i>Weight</i>        | 51   |



|             |  |       |
|-------------|--|-------|
| <b>1892</b> | Çevre (mm)<br><i>Perimeter</i>         | 240,6 |
|             | Alan (mm <sup>2</sup> )<br><i>Area</i> | 192,4 |
|             | Ağırlık (gr/m)<br><i>Weight</i>        | 521   |

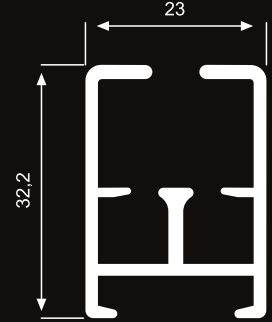

|             |  |       |
|-------------|--|-------|
| <b>1884</b> | Çevre (mm)<br><i>Perimeter</i>         | 240,9 |
|             | Alan (mm <sup>2</sup> )<br><i>Area</i> | 174,8 |
|             | Ağırlık (gr/m)<br><i>Weight</i>        | 474   |

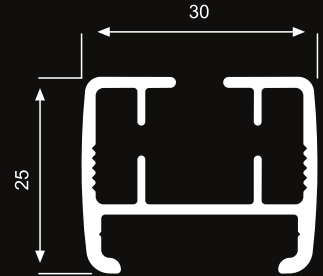

|             |  |       |
|-------------|--|-------|
| <b>1890</b> | Çevre (mm)<br><i>Perimeter</i>         | 162,5 |
|             | Alan (mm <sup>2</sup> )<br><i>Area</i> | 70    |
|             | Ağırlık (gr/m)<br><i>Weight</i>        | 190   |





**1752**

|                                 |       |
|---------------------------------|-------|
| Çevre (mm)<br>Perimeter         | 225   |
| Alan (mm <sup>2</sup> )<br>Area | 131   |
| Ağırlık (gr/m)<br>Weight        | 0.355 |

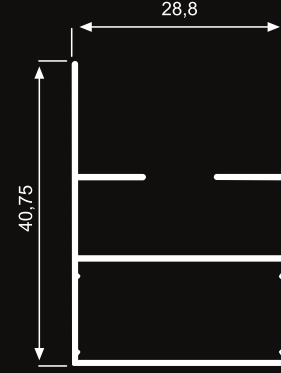

**1753**

|                                 |     |
|---------------------------------|-----|
| Çevre (mm)<br>Perimeter         | 223 |
| Alan (mm <sup>2</sup> )<br>Area | 129 |
| Ağırlık (gr/m)<br>Weight        | 349 |

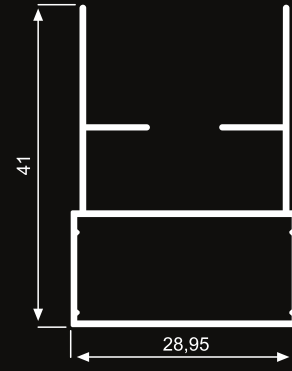

**1754**

|                                 |       |
|---------------------------------|-------|
| Çevre (mm)<br>Perimeter         | 320   |
| Alan (mm <sup>2</sup> )<br>Area | 206   |
| Ağırlık (gr/m)<br>Weight        | 0.558 |

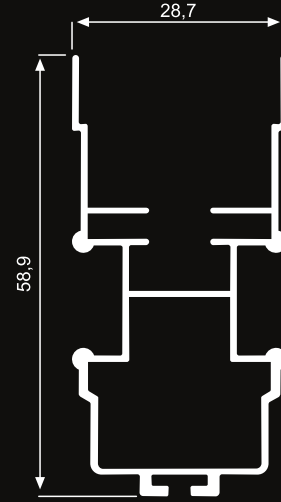

**1773**

|                                 |       |
|---------------------------------|-------|
| Çevre (mm)<br>Perimeter         | 238.5 |
| Alan (mm <sup>2</sup> )<br>Area | 318.5 |
| Ağırlık (gr/m)<br>Weight        | 864   |

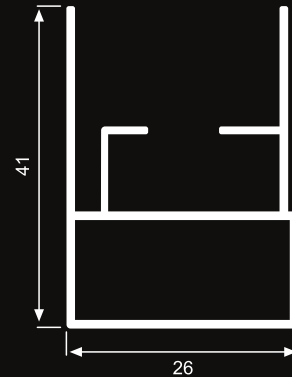



Alaşım Alüminyum

|             |  |     |
|-------------|--|-----|
| <b>1756</b> | Çevre (mm)<br><i>Perimeter</i>         | 118 |
|             | Alan (mm <sup>2</sup> )<br><i>Area</i> | 103 |
|             | Ağırlık (gr/m)<br><i>Weight</i>        | 279 |

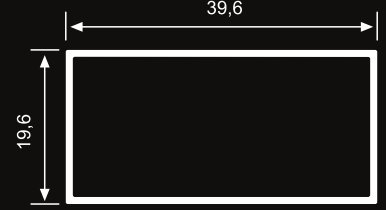

|             |  |     |
|-------------|--|-----|
| <b>1757</b> | Çevre (mm)<br><i>Perimeter</i>         | 132 |
|             | Alan (mm <sup>2</sup> )<br><i>Area</i> | 138 |
|             | Ağırlık (gr/m)<br><i>Weight</i>        | 374 |

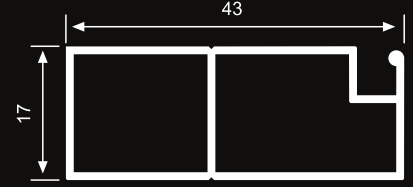

|             |  |      |
|-------------|--|------|
| <b>1758</b> | Çevre (mm)<br><i>Perimeter</i>         | 94,6 |
|             | Alan (mm <sup>2</sup> )<br><i>Area</i> | 77,5 |
|             | Ağırlık (gr/m)<br><i>Weight</i>        | 210  |

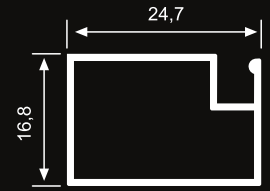

|             |  |       |
|-------------|--|-------|
| <b>1755</b> | Çevre (mm)<br><i>Perimeter</i>         | 115,9 |
|             | Alan (mm <sup>2</sup> )<br><i>Area</i> | 92,9  |
|             | Ağırlık (gr/m)<br><i>Weight</i>        | 252   |

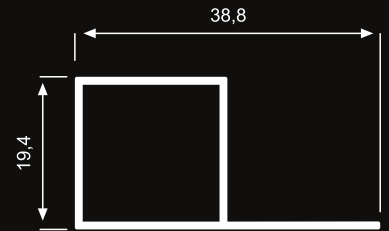



Alaşım Alüminyum

**2345**

|  |       |
|--|-------|
| Çevre (mm)<br><i>Perimeter</i>         | 139,2 |
| Alan (mm <sup>2</sup> )<br><i>Area</i> | 139,9 |
| Ağırlık (gr/m)<br><i>Weight</i>        | 379   |

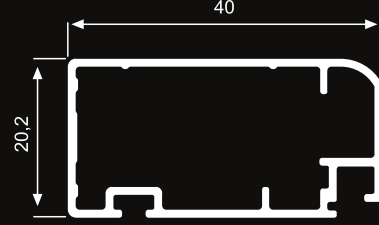

**2347**

|  |      |
|--|------|
| Çevre (mm)<br><i>Perimeter</i>         | 8,24 |
| Alan (mm <sup>2</sup> )<br><i>Area</i> | 57,5 |
| Ağırlık (gr/m)<br><i>Weight</i>        | 155  |

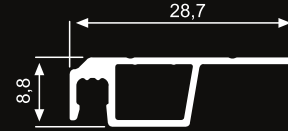

**2367**

|  |       |
|--|-------|
| Çevre (mm)<br><i>Perimeter</i>         | 139,3 |
| Alan (mm <sup>2</sup> )<br><i>Area</i> | 139,5 |
| Ağırlık (gr/m)<br><i>Weight</i>        | 378   |

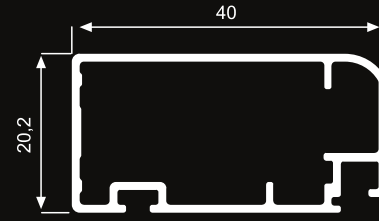

**2368**

|  |      |
|--|------|
| Çevre (mm)<br><i>Perimeter</i>         | 82,6 |
| Alan (mm <sup>2</sup> )<br><i>Area</i> | 57,7 |
| Ağırlık (gr/m)<br><i>Weight</i>        | 156  |

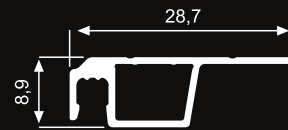

SİNEKLİK PROFİLLERİ  
INSECT SCREEN PROFILES



Alaşım Alüminyum

|             |  |       |
|-------------|--|-------|
| <b>2369</b> | Çevre (mm)<br><i>Perimeter</i>         | 129,7 |
|             | Alan (mm <sup>2</sup> )<br><i>Area</i> | 106,8 |
|             | Ağırlık (gr/m)<br><i>Weight</i>        | 289   |

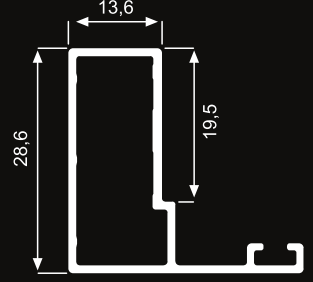

|             |  |      |
|-------------|--|------|
| <b>2370</b> | Çevre (mm)<br><i>Perimeter</i>         | 107  |
|             | Alan (mm <sup>2</sup> )<br><i>Area</i> | 61,7 |
|             | Ağırlık (gr/m)<br><i>Weight</i>        | 167  |



|             |  |       |
|-------------|--|-------|
| <b>2371</b> | Çevre (mm)<br><i>Perimeter</i>         | 266,8 |
|             | Alan (mm <sup>2</sup> )<br><i>Area</i> | 174,7 |
|             | Ağırlık (gr/m)<br><i>Weight</i>        | 473   |

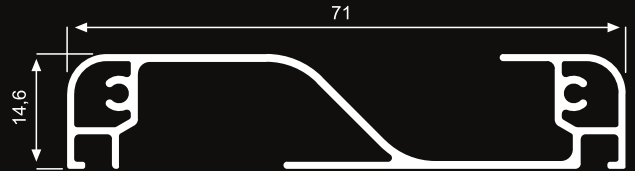



## Alaşım Alüminyum

|             |  |    |
|-------------|--|----|
| <b>1760</b> | Çevre (mm)<br><i>Perimeter</i>         | 80 |
|             | Alan (mm <sup>2</sup> )<br><i>Area</i> | 33 |
|             | Ağırlık (gr/m)<br><i>Weight</i>        | 91 |



|             |  |      |
|-------------|--|------|
| <b>1784</b> | Çevre (mm)<br><i>Perimeter</i>         | 81.9 |
|             | Alan (mm <sup>2</sup> )<br><i>Area</i> | 37.5 |
|             | Ağırlık (gr/m)<br><i>Weight</i>        | 101  |

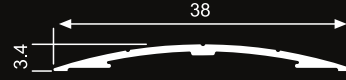

|             |  |      |
|-------------|--|------|
| <b>1787</b> | Çevre (mm)<br><i>Perimeter</i>         | 80.6 |
|             | Alan (mm <sup>2</sup> )<br><i>Area</i> | 34.8 |
|             | Ağırlık (gr/m)<br><i>Weight</i>        | 94   |



|             |  |      |
|-------------|--|------|
| <b>1829</b> | Çevre (mm)<br><i>Perimeter</i>         | 80.8 |
|             | Alan (mm <sup>2</sup> )<br><i>Area</i> | 32.1 |
|             | Ağırlık (gr/m)<br><i>Weight</i>        | 86   |



|             |  |      |
|-------------|--|------|
| <b>1835</b> | Çevre (mm)<br><i>Perimeter</i>         | 81.6 |
|             | Alan (mm <sup>2</sup> )<br><i>Area</i> | 38.2 |
|             | Ağırlık (gr/m)<br><i>Weight</i>        | 104  |

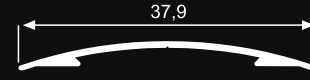

|             |  |    |
|-------------|--|----|
| <b>2119</b> | Çevre (mm)<br><i>Perimeter</i>         | 79 |
|             | Alan (mm <sup>2</sup> )<br><i>Area</i> | 30 |
|             | Ağırlık (gr/m)<br><i>Weight</i>        | 83 |



|             |  |      |
|-------------|--|------|
| <b>1854</b> | Çevre (mm)<br><i>Perimeter</i>         | 80.9 |
|             | Alan (mm <sup>2</sup> )<br><i>Area</i> | 32.2 |
|             | Ağırlık (gr/m)<br><i>Weight</i>        | 87   |





## Alaşım Alüminyum

|             |  |     |
|-------------|--|-----|
| <b>2039</b> | Çevre (mm)<br><i>Perimeter</i>         | 82  |
|             | Alan (mm <sup>2</sup> )<br><i>Area</i> | 42  |
|             | Ağırlık (gr/m)<br><i>Weight</i>        | 114 |



|             |  |     |
|-------------|--|-----|
| <b>1846</b> | Çevre (mm)<br><i>Perimeter</i>         | 97  |
|             | Alan (mm <sup>2</sup> )<br><i>Area</i> | 49  |
|             | Ağırlık (gr/m)<br><i>Weight</i>        | 135 |



|             |  |       |
|-------------|--|-------|
| <b>1786</b> | Çevre (mm)<br><i>Perimeter</i>         | 113.2 |
|             | Alan (mm <sup>2</sup> )<br><i>Area</i> | 49.1  |
|             | Ağırlık (gr/m)<br><i>Weight</i>        | 133   |

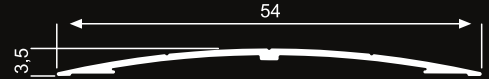

|             |  |      |
|-------------|--|------|
| <b>1840</b> | Çevre (mm)<br><i>Perimeter</i>         | 97.5 |
|             | Alan (mm <sup>2</sup> )<br><i>Area</i> | 54   |
|             | Ağırlık (gr/m)<br><i>Weight</i>        | 147  |

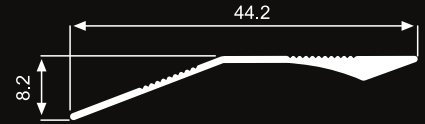

|             |  |      |
|-------------|--|------|
| <b>1783</b> | Çevre (mm)<br><i>Perimeter</i>         | 89   |
|             | Alan (mm <sup>2</sup> )<br><i>Area</i> | 49.3 |
|             | Ağırlık (gr/m)<br><i>Weight</i>        | 134  |

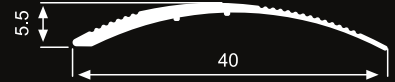

|             |  |      |
|-------------|--|------|
| <b>1836</b> | Çevre (mm)<br><i>Perimeter</i>         | 90.8 |
|             | Alan (mm <sup>2</sup> )<br><i>Area</i> | 53.9 |
|             | Ağırlık (gr/m)<br><i>Weight</i>        | 146  |



|             |  |      |
|-------------|--|------|
| <b>2127</b> | Çevre (mm)<br><i>Perimeter</i>         | 67.6 |
|             | Alan (mm <sup>2</sup> )<br><i>Area</i> | 46.3 |
|             | Ağırlık (gr/m)<br><i>Weight</i>        | 126  |

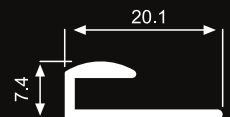





Alaşım Alüminyum

|             |                                 |      |
|-------------|---------------------------------|------|
| <b>2199</b> | Çevre (mm)<br>Perimeter         | 79   |
|             | Alan (mm <sup>2</sup> )<br>Area | 27.5 |
|             | Ağırlık (gr/m)<br>Weight        | 75   |



|             |                                 |      |
|-------------|---------------------------------|------|
| <b>1779</b> | Çevre (mm)<br>Perimeter         | 81   |
|             | Alan (mm <sup>2</sup> )<br>Area | 37.6 |
|             | Ağırlık (gr/m)<br>Weight        | 102  |

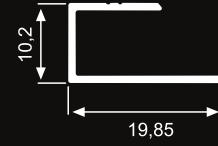

|             |                                 |      |
|-------------|---------------------------------|------|
| <b>1780</b> | Çevre (mm)<br>Perimeter         | 91.8 |
|             | Alan (mm <sup>2</sup> )<br>Area | 38.5 |
|             | Ağırlık (gr/m)<br>Weight        | 104  |

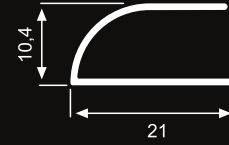

|             |                                 |       |
|-------------|---------------------------------|-------|
| <b>1818</b> | Çevre (mm)<br>Perimeter         | 123.5 |
|             | Alan (mm <sup>2</sup> )<br>Area | 42.7  |
|             | Ağırlık (gr/m)<br>Weight        | 116   |



|             |                                 |      |
|-------------|---------------------------------|------|
| <b>1781</b> | Çevre (mm)<br>Perimeter         | 141  |
|             | Alan (mm <sup>2</sup> )<br>Area | 55.4 |
|             | Ağırlık (gr/m)<br>Weight        | 150  |

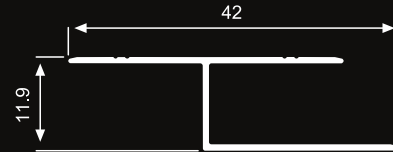

|             |                                 |     |
|-------------|---------------------------------|-----|
| <b>1782</b> | Çevre (mm)<br>Perimeter         | 125 |
|             | Alan (mm <sup>2</sup> )<br>Area | 49  |
|             | Ağırlık (gr/m)<br>Weight        | 132 |

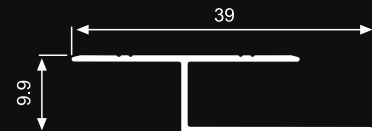

|             |                                 |      |
|-------------|---------------------------------|------|
| <b>1869</b> | Çevre (mm)<br>Perimeter         | 154  |
|             | Alan (mm <sup>2</sup> )<br>Area | 60.6 |
|             | Ağırlık (gr/m)<br>Weight        | 164  |

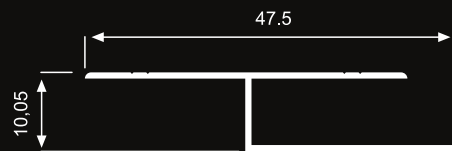



Alaşım Alüminyum

|             |  |       |
|-------------|--|-------|
| <b>1828</b> | Çevre (mm)<br><i>Perimeter</i>         | 122.1 |
|             | Alan (mm <sup>2</sup> )<br><i>Area</i> | 61.3  |
|             | Ağırlık (gr/m)<br><i>Weight</i>        | 166   |

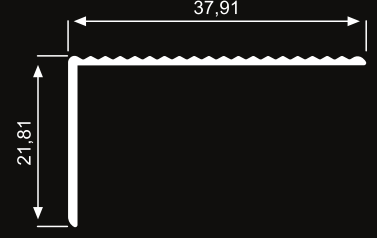

|             |  |       |
|-------------|--|-------|
| <b>2153</b> | Çevre (mm)<br><i>Perimeter</i>         | 135.4 |
|             | Alan (mm <sup>2</sup> )<br><i>Area</i> | 98.7  |
|             | Ağırlık (gr/m)<br><i>Weight</i>        | 268   |

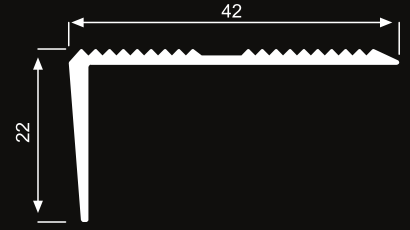

|             |  |      |
|-------------|--|------|
| <b>1785</b> | Çevre (mm)<br><i>Perimeter</i>         | 96.5 |
|             | Alan (mm <sup>2</sup> )<br><i>Area</i> | 48.4 |
|             | Ağırlık (gr/m)<br><i>Weight</i>        | 131  |

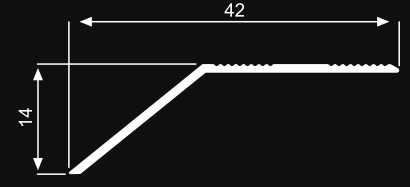

|             |  |      |
|-------------|--|------|
| <b>1826</b> | Çevre (mm)<br><i>Perimeter</i>         | 80.4 |
|             | Alan (mm <sup>2</sup> )<br><i>Area</i> | 32.6 |
|             | Ağırlık (gr/m)<br><i>Weight</i>        | 88   |

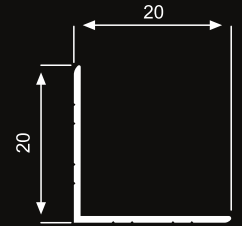

|             |  |       |
|-------------|--|-------|
| <b>1827</b> | Çevre (mm)<br><i>Perimeter</i>         | 121.1 |
|             | Alan (mm <sup>2</sup> )<br><i>Area</i> | 46.6  |
|             | Ağırlık (gr/m)<br><i>Weight</i>        | 126   |

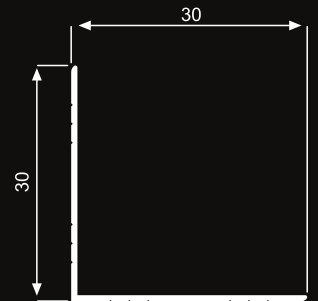



Alaşım Alüminyum

|             |                                 |     |
|-------------|---------------------------------|-----|
| <b>1853</b> | Çevre (mm)<br>Perimeter         | 154 |
|             | Alan (mm <sup>2</sup> )<br>Area | 86  |
|             | Ağırlık (gr/m)<br>Weight        | 235 |

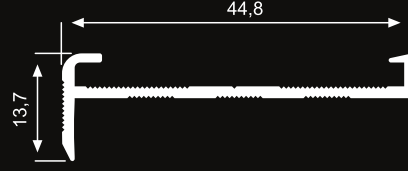

|             |                                 |      |
|-------------|---------------------------------|------|
| <b>2437</b> | Çevre (mm)<br>Perimeter         | 58,1 |
|             | Alan (mm <sup>2</sup> )<br>Area | 44   |
|             | Ağırlık (gr/m)<br>Weight        | 119  |

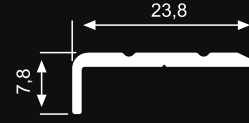

|             |                                 |      |
|-------------|---------------------------------|------|
| <b>1839</b> | Çevre (mm)<br>Perimeter         | 66,3 |
|             | Alan (mm <sup>2</sup> )<br>Area | 39,4 |
|             | Ağırlık (gr/m)<br>Weight        | 107  |

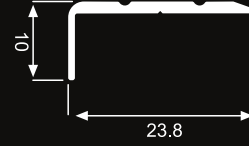

|             |                                 |      |
|-------------|---------------------------------|------|
| <b>2436</b> | Çevre (mm)<br>Perimeter         | 78,1 |
|             | Alan (mm <sup>2</sup> )<br>Area | 56   |
|             | Ağırlık (gr/m)<br>Weight        | 152  |

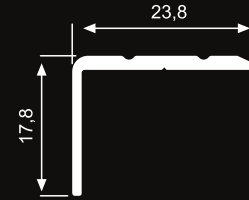

|             |                                 |     |
|-------------|---------------------------------|-----|
| <b>2040</b> | Çevre (mm)<br>Perimeter         | 90  |
|             | Alan (mm <sup>2</sup> )<br>Area | 56  |
|             | Ağırlık (gr/m)<br>Weight        | 151 |

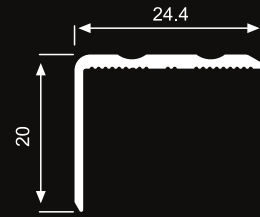

|             |                                 |     |
|-------------|---------------------------------|-----|
| <b>2041</b> | Çevre (mm)<br>Perimeter         | 89  |
|             | Alan (mm <sup>2</sup> )<br>Area | 72  |
|             | Ağırlık (gr/m)<br>Weight        | 194 |

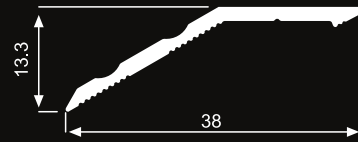

|             |                                 |     |
|-------------|---------------------------------|-----|
| <b>2042</b> | Çevre (mm)<br>Perimeter         | 97  |
|             | Alan (mm <sup>2</sup> )<br>Area | 77  |
|             | Ağırlık (gr/m)<br>Weight        | 207 |

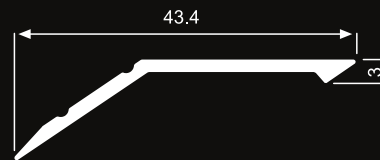



Alaşım Alüminyum

**2332**

\* Özel üründür

|  |      |
|--|------|
| Çevre (mm)<br><i>Perimeter</i>         | 93,9 |
| Alan (mm <sup>2</sup> )<br><i>Area</i> | 67,6 |
| Ağırlık (gr/m)<br><i>Weight</i>        | 184  |

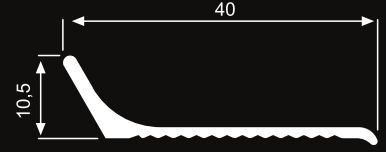

**2205**

\* Özel üründür

|  |       |
|--|-------|
| Çevre (mm)<br><i>Perimeter</i>         | 132,8 |
| Alan (mm <sup>2</sup> )<br><i>Area</i> | 117,7 |
| Ağırlık (gr/m)<br><i>Weight</i>        | 319   |



**2206**

\* Özel üründür

|  |       |
|--|-------|
| Çevre (mm)<br><i>Perimeter</i>         | 137,6 |
| Alan (mm <sup>2</sup> )<br><i>Area</i> | 84,5  |
| Ağırlık (gr/m)<br><i>Weight</i>        | 229   |



**2331**

\* Özel üründür

|  |       |
|--|-------|
| Çevre (mm)<br><i>Perimeter</i>         | 177,4 |
| Alan (mm <sup>2</sup> )<br><i>Area</i> | 116   |
| Ağırlık (gr/m)<br><i>Weight</i>        | 314   |





Alaşım Alüminyum

## 2296

\* Özel üründür

|                                 |       |
|---------------------------------|-------|
| Çevre (mm)<br>Perimeter         | 214,6 |
| Alan (mm <sup>2</sup> )<br>Area | 176,8 |
| Ağırlık (gr/m)<br>Weight        | 479   |



## 2333

\* Özel üründür

|                                 |       |
|---------------------------------|-------|
| Çevre (mm)<br>Perimeter         | 221,1 |
| Alan (mm <sup>2</sup> )<br>Area | 140,4 |
| Ağırlık (gr/m)<br>Weight        | 380   |

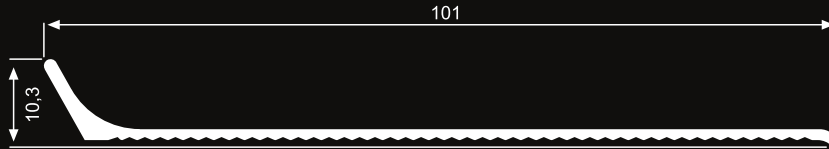

## 2362

\* Özel üründür

|                                 |       |
|---------------------------------|-------|
| Çevre (mm)<br>Perimeter         | 171,7 |
| Alan (mm <sup>2</sup> )<br>Area | 133,9 |
| Ağırlık (gr/m)<br>Weight        | 363   |

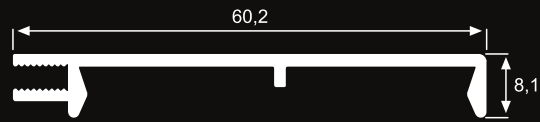



## Alaşım Alüminyum

|             |  |     |
|-------------|--|-----|
| <b>1868</b> | Çevre (mm)<br><i>Perimeter</i>         | 287 |
|             | Alan (mm <sup>2</sup> )<br><i>Area</i> | 362 |
|             | Ağırlık (gr/m)<br><i>Weight</i>        | 981 |



|             |  |      |
|-------------|--|------|
| <b>2033</b> | Çevre (mm)<br><i>Perimeter</i>         | 304  |
|             | Alan (mm <sup>2</sup> )<br><i>Area</i> | 600  |
|             | Ağırlık (gr/m)<br><i>Weight</i>        | 1626 |

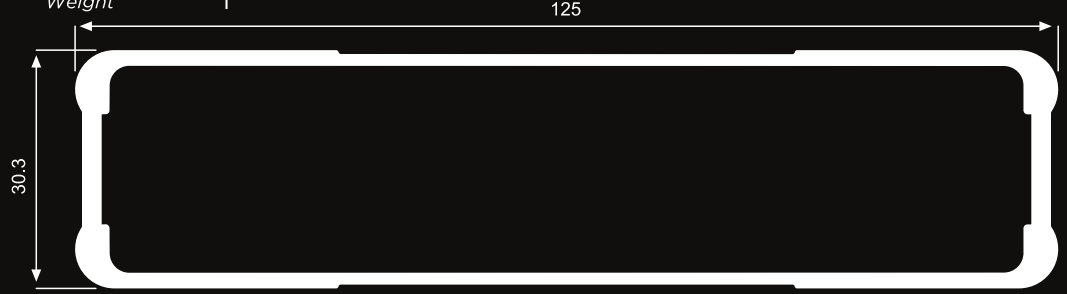

|             |  |      |
|-------------|--|------|
| <b>2034</b> | Çevre (mm)<br><i>Perimeter</i>         | 282  |
|             | Alan (mm <sup>2</sup> )<br><i>Area</i> | 490  |
|             | Ağırlık (gr/m)<br><i>Weight</i>        | 1328 |

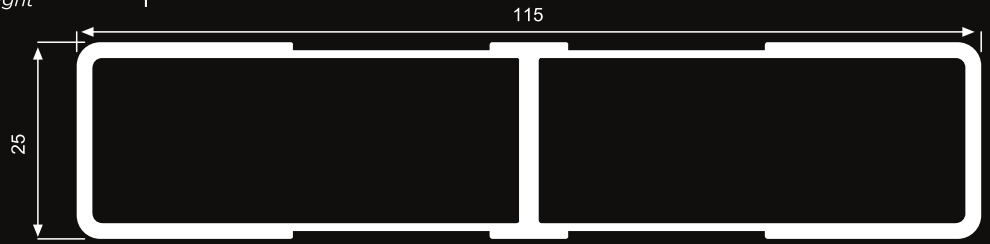

|             |  |      |
|-------------|--|------|
| <b>1883</b> | Çevre (mm)<br><i>Perimeter</i>         | 263  |
|             | Alan (mm <sup>2</sup> )<br><i>Area</i> | 383  |
|             | Ağırlık (gr/m)<br><i>Weight</i>        | 1037 |

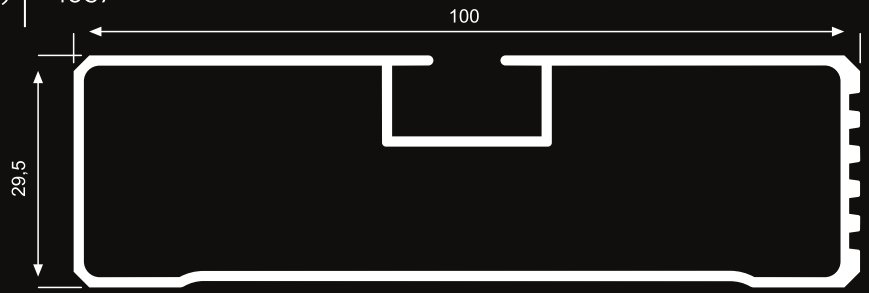



## 1990

|                                   |       |
|-----------------------------------|-------|
| Genişlik (mm)<br><i>Width</i>     | 21.7  |
| Yükseklik (mm)<br><i>Height</i>   | 14.4  |
| Gramaj (kg/mt)<br><i>Weight</i>   | 0.138 |
| Kalınlık (mm)<br><i>Thickness</i> | 0.75  |

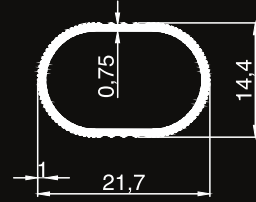

## 1991

|                                   |       |
|-----------------------------------|-------|
| Genişlik (mm)<br><i>Width</i>     | 6.7   |
| Yükseklik (mm)<br><i>Height</i>   | 14.7  |
| Gramaj (kg/mt)<br><i>Weight</i>   | 0.066 |
| Kalınlık (mm)<br><i>Thickness</i> | 0.7   |



## 1992

|                                   |       |
|-----------------------------------|-------|
| Genişlik (mm)<br><i>Width</i>     | 29.2  |
| Yükseklik (mm)<br><i>Height</i>   | 15.8  |
| Gramaj (kg/mt)<br><i>Weight</i>   | 0.192 |
| Kalınlık (mm)<br><i>Thickness</i> | 1     |

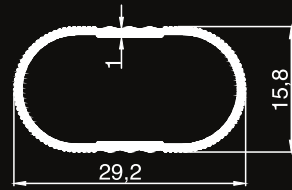

## 1993

|                                   |       |
|-----------------------------------|-------|
| Genişlik (mm)<br><i>Width</i>     | 30    |
| Yükseklik (mm)<br><i>Height</i>   | 15    |
| Gramaj (kg/mt)<br><i>Weight</i>   | 0.238 |
| Kalınlık (mm)<br><i>Thickness</i> | 1.2   |

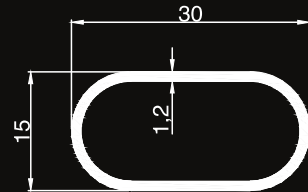



Alaşım Alüminyum

|             |                                   |       |
|-------------|-----------------------------------|-------|
| <b>1994</b> | Genişlik (mm)<br><i>Width</i>     | 27    |
|             | Yükseklik (mm)<br><i>Height</i>   | 14    |
|             | Gramaj (kg/mt)<br><i>Weight</i>   | 0.195 |
|             | Kalınlık (mm)<br><i>Thickness</i> | 1.2   |

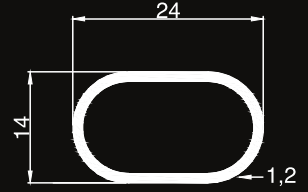

|             |                                   |       |
|-------------|-----------------------------------|-------|
| <b>1995</b> | Genişlik (mm)<br><i>Width</i>     | 27    |
|             | Yükseklik (mm)<br><i>Height</i>   | 15.2  |
|             | Gramaj (kg/mt)<br><i>Weight</i>   | 0.138 |
|             | Kalınlık (mm)<br><i>Thickness</i> | 0.83  |

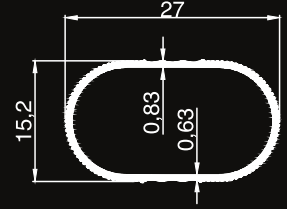

|             |                                   |       |
|-------------|-----------------------------------|-------|
| <b>1996</b> | Genişlik (mm)<br><i>Width</i>     | 26.4  |
|             | Yükseklik (mm)<br><i>Height</i>   | -     |
|             | Gramaj (kg/mt)<br><i>Weight</i>   | 0.127 |
|             | Kalınlık (mm)<br><i>Thickness</i> | 0.8   |

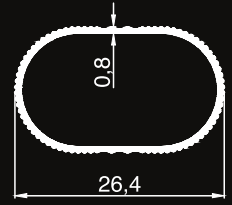

|             |                                   |       |
|-------------|-----------------------------------|-------|
| <b>1997</b> | Genişlik (mm)<br><i>Width</i>     | 9.97  |
|             | Yükseklik (mm)<br><i>Height</i>   | 8     |
|             | Gramaj (kg/mt)<br><i>Weight</i>   | 0.068 |
|             | Kalınlık (mm)<br><i>Thickness</i> | 0.8   |

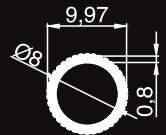





Alaşım Alüminyum

**1998**

|                                   |       |
|-----------------------------------|-------|
| Genişlik (mm)<br><i>Width</i>     | 54.4  |
| Yükseklik (mm)<br><i>Height</i>   | 5.8   |
| Gramaj (kg/mt)<br><i>Weight</i>   | 0.190 |
| Kalınlık (mm)<br><i>Thickness</i> | 0.8   |

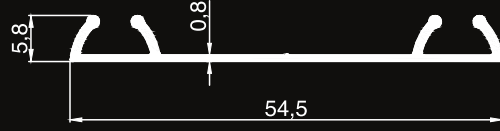

**1999**

|                                   |       |
|-----------------------------------|-------|
| Genişlik (mm)<br><i>Width</i>     | 60    |
| Yükseklik (mm)<br><i>Height</i>   | 6.3   |
| Gramaj (kg/mt)<br><i>Weight</i>   | 0.252 |
| Kalınlık (mm)<br><i>Thickness</i> | 1.1   |

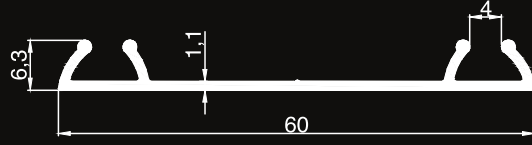

**2000**

|                                   |       |
|-----------------------------------|-------|
| Genişlik (mm)<br><i>Width</i>     | 59.88 |
| Yükseklik (mm)<br><i>Height</i>   | 6     |
| Gramaj (kg/mt)<br><i>Weight</i>   | 0.203 |
| Kalınlık (mm)<br><i>Thickness</i> | 0.8   |

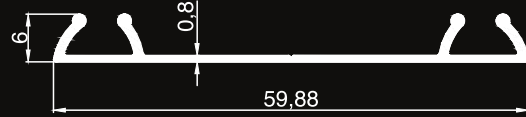

**2001**

|                                   |       |
|-----------------------------------|-------|
| Genişlik (mm)<br><i>Width</i>     | 29.9  |
| Yükseklik (mm)<br><i>Height</i>   | 14.9  |
| Gramaj (kg/mt)<br><i>Weight</i>   | 0.173 |
| Kalınlık (mm)<br><i>Thickness</i> | 0.9   |

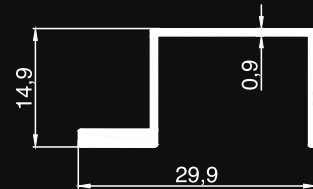



Alaşım Alüminyum

|             |                                   |       |
|-------------|-----------------------------------|-------|
| <b>2002</b> | Genişlik (mm)<br><i>Width</i>     | 30    |
|             | Yükseklik (mm)<br><i>Height</i>   | 15    |
|             | Gramaj (kg/mt)<br><i>Weight</i>   | 0.206 |
|             | Kalınlık (mm)<br><i>Thickness</i> | 1     |

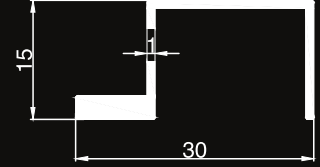

|             |                                   |       |
|-------------|-----------------------------------|-------|
| <b>2003</b> | Genişlik (mm)<br><i>Width</i>     | 33.2  |
|             | Yükseklik (mm)<br><i>Height</i>   | 15    |
|             | Gramaj (kg/mt)<br><i>Weight</i>   | 0.274 |
|             | Kalınlık (mm)<br><i>Thickness</i> | 1.1   |

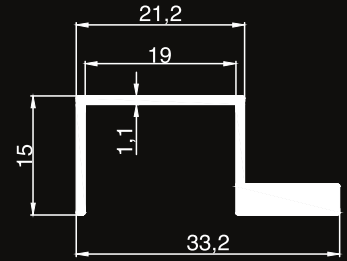

|             |                                   |       |
|-------------|-----------------------------------|-------|
| <b>2004</b> | Genişlik (mm)<br><i>Width</i>     | 32.5  |
|             | Yükseklik (mm)<br><i>Height</i>   | 14.9  |
|             | Gramaj (kg/mt)<br><i>Weight</i>   | 0.238 |
|             | Kalınlık (mm)<br><i>Thickness</i> | 0.9   |

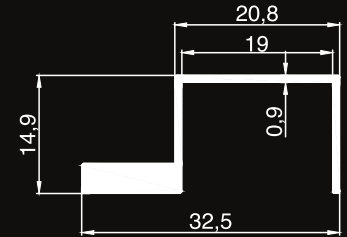

|             |                                   |       |
|-------------|-----------------------------------|-------|
| <b>2005</b> | Genişlik (mm)<br><i>Width</i>     | 35.9  |
|             | Yükseklik (mm)<br><i>Height</i>   | 39.9  |
|             | Gramaj (kg/mt)<br><i>Weight</i>   | 0.425 |
|             | Kalınlık (mm)<br><i>Thickness</i> | 1.2   |

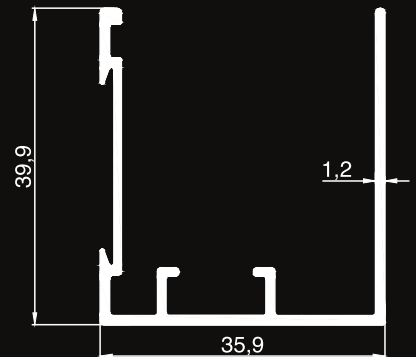



Alaşım Alüminyum

## 2006

|                                   |       |
|-----------------------------------|-------|
| Genişlik (mm)<br><i>Width</i>     | 71.6  |
| Yükseklik (mm)<br><i>Height</i>   | 41.5  |
| Gramaj (kg/mt)<br><i>Weight</i>   | 0.615 |
| Kalınlık (mm)<br><i>Thickness</i> | 1     |

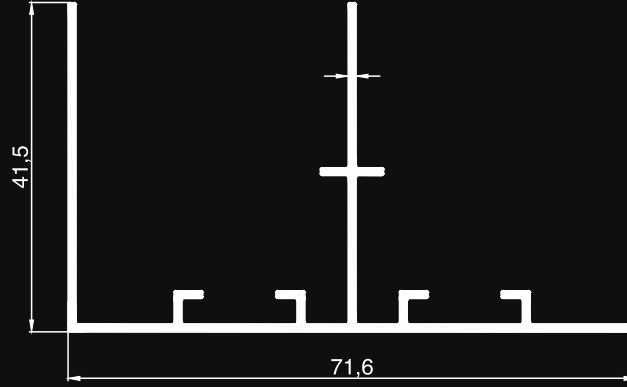

## 2007

|                                   |       |
|-----------------------------------|-------|
| Genişlik (mm)<br><i>Width</i>     | 71.6  |
| Yükseklik (mm)<br><i>Height</i>   | 41.5  |
| Gramaj (kg/mt)<br><i>Weight</i>   | 0.748 |
| Kalınlık (mm)<br><i>Thickness</i> | 1.3   |

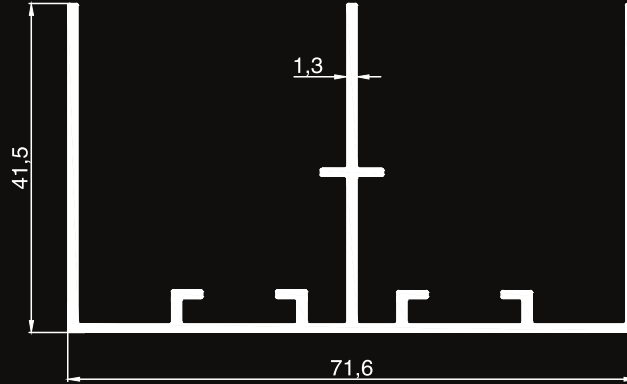

## 2008

|                                   |       |
|-----------------------------------|-------|
| Genişlik (mm)<br><i>Width</i>     | 67.95 |
| Yükseklik (mm)<br><i>Height</i>   | 39.89 |
| Gramaj (kg/mt)<br><i>Weight</i>   | 0.596 |
| Kalınlık (mm)<br><i>Thickness</i> | 1     |

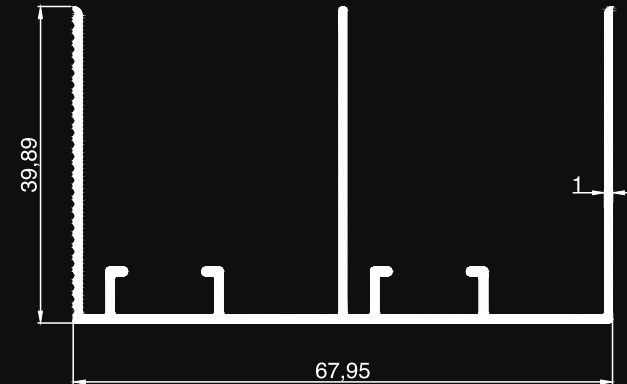



Alaşım Alüminyum

**2009**

|                                   |       |
|-----------------------------------|-------|
| Genişlik (mm)<br><i>Width</i>     | 79    |
| Yükseklik (mm)<br><i>Height</i>   | 45    |
| Gramaj (kg/mt)<br><i>Weight</i>   | 0.655 |
| Kalınlık (mm)<br><i>Thickness</i> | 1     |

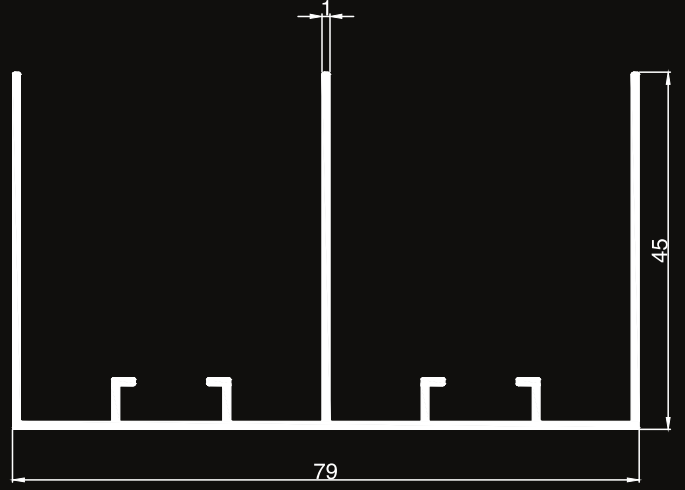

**2010**

|                                   |       |
|-----------------------------------|-------|
| Genişlik (mm)<br><i>Width</i>     | 70.9  |
| Yükseklik (mm)<br><i>Height</i>   | 51.4  |
| Gramaj (kg/mt)<br><i>Weight</i>   | 0.802 |
| Kalınlık (mm)<br><i>Thickness</i> | 1.1   |

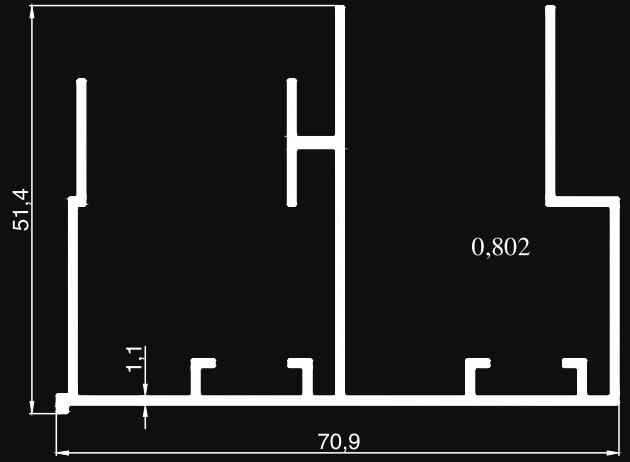

**2011**

|                                   |       |
|-----------------------------------|-------|
| Genişlik (mm)<br><i>Width</i>     | 58.8  |
| Yükseklik (mm)<br><i>Height</i>   | 19.8  |
| Gramaj (kg/mt)<br><i>Weight</i>   | 0.398 |
| Kalınlık (mm)<br><i>Thickness</i> | 1     |

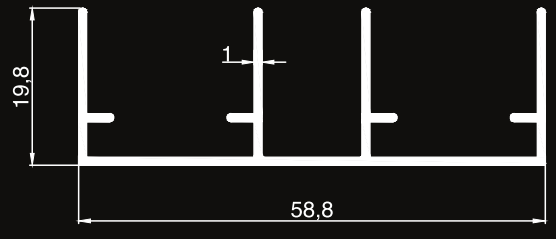



## 2012

|                                   |       |
|-----------------------------------|-------|
| Genişlik (mm)<br><i>Width</i>     | 79.6  |
| Yükseklik (mm)<br><i>Height</i>   | 44.5  |
| Gramaj (kg/mt)<br><i>Weight</i>   | 0.569 |
| Kalınlık (mm)<br><i>Thickness</i> | 1     |

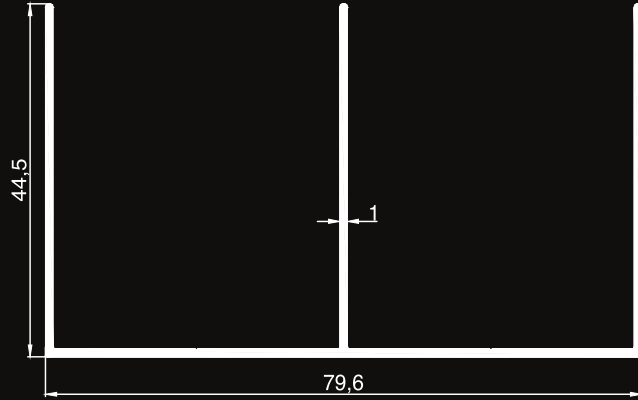

## 2013

|                                   |       |
|-----------------------------------|-------|
| Genişlik (mm)<br><i>Width</i>     | 67.8  |
| Yükseklik (mm)<br><i>Height</i>   | 39.7  |
| Gramaj (kg/mt)<br><i>Weight</i>   | 0.566 |
| Kalınlık (mm)<br><i>Thickness</i> | 1     |

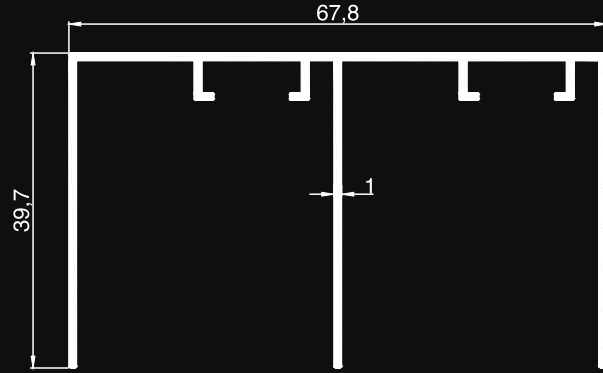

## 2014

|                                   |       |
|-----------------------------------|-------|
| Genişlik (mm)<br><i>Width</i>     | 40.5  |
| Yükseklik (mm)<br><i>Height</i>   | 20    |
| Gramaj (kg/mt)<br><i>Weight</i>   | 0.304 |
| Kalınlık (mm)<br><i>Thickness</i> | 1.2   |

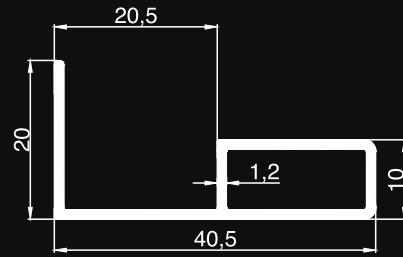

## 2015

|                                   |       |
|-----------------------------------|-------|
| Genişlik (mm)<br><i>Width</i>     | 40.6  |
| Yükseklik (mm)<br><i>Height</i>   | 19.8  |
| Gramaj (kg/mt)<br><i>Weight</i>   | 0.255 |
| Kalınlık (mm)<br><i>Thickness</i> | 1     |

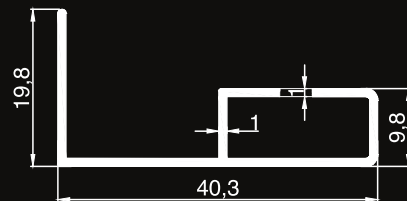



Alaşım Alüminyum

|             |                                   |       |
|-------------|-----------------------------------|-------|
| <b>2016</b> | Genişlik (mm)<br><i>Width</i>     | 33.1  |
|             | Yükseklik (mm)<br><i>Height</i>   | 25.2  |
|             | Gramaj (kg/mt)<br><i>Weight</i>   | 0.360 |
|             | Kalınlık (mm)<br><i>Thickness</i> | 1.3   |

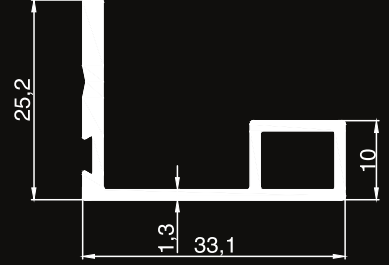

|             |                                   |       |
|-------------|-----------------------------------|-------|
| <b>2017</b> | Genişlik (mm)<br><i>Width</i>     | 21.2  |
|             | Yükseklik (mm)<br><i>Height</i>   | 20.8  |
|             | Gramaj (kg/mt)<br><i>Weight</i>   | 0.195 |
|             | Kalınlık (mm)<br><i>Thickness</i> | 1     |

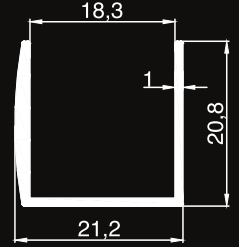

|             |                                   |       |
|-------------|-----------------------------------|-------|
| <b>2018</b> | Genişlik (mm)<br><i>Width</i>     | 19.2  |
|             | Yükseklik (mm)<br><i>Height</i>   | 17.8  |
|             | Gramaj (kg/mt)<br><i>Weight</i>   | 0.171 |
|             | Kalınlık (mm)<br><i>Thickness</i> | 1     |

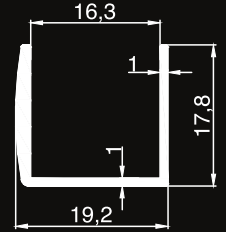

|             |                                   |       |
|-------------|-----------------------------------|-------|
| <b>2019</b> | Genişlik (mm)<br><i>Width</i>     | 20.6  |
|             | Yükseklik (mm)<br><i>Height</i>   | 15    |
|             | Gramaj (kg/mt)<br><i>Weight</i>   | 0.127 |
|             | Kalınlık (mm)<br><i>Thickness</i> | 1     |

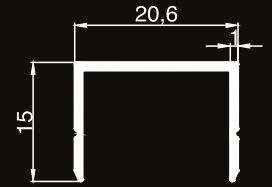

|             |                                   |       |
|-------------|-----------------------------------|-------|
| <b>2020</b> | Genişlik (mm)<br><i>Width</i>     | 21.1  |
|             | Yükseklik (mm)<br><i>Height</i>   | 19.4  |
|             | Gramaj (kg/mt)<br><i>Weight</i>   | 0.146 |
|             | Kalınlık (mm)<br><i>Thickness</i> | 1.1   |

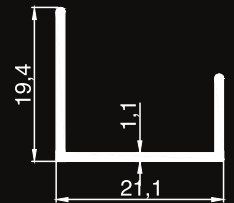



## Alaşım Alüminyum

### 2021

|                                   |       |
|-----------------------------------|-------|
| Genişlik (mm)<br><i>Width</i>     | 8.98  |
| Yükseklik (mm)<br><i>Height</i>   | 6.87  |
| Gramaj (kg/mt)<br><i>Weight</i>   | 0.087 |
| Kalınlık (mm)<br><i>Thickness</i> | -     |

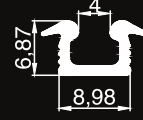

### 2022

|                                   |       |
|-----------------------------------|-------|
| Genişlik (mm)<br><i>Width</i>     | 20.3  |
| Yükseklik (mm)<br><i>Height</i>   | 38    |
| Gramaj (kg/mt)<br><i>Weight</i>   | 0.225 |
| Kalınlık (mm)<br><i>Thickness</i> | 0.9   |

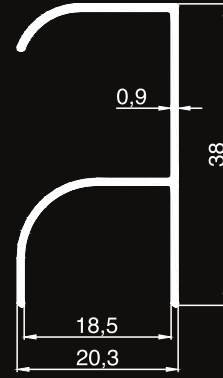

### 2023

|                                   |       |
|-----------------------------------|-------|
| Genişlik (mm)<br><i>Width</i>     | 21.1  |
| Yükseklik (mm)<br><i>Height</i>   | 42.4  |
| Gramaj (kg/mt)<br><i>Weight</i>   | 0.268 |
| Kalınlık (mm)<br><i>Thickness</i> | 0.8   |

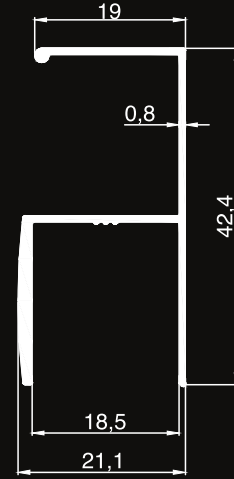

### 2024

|                                   |       |
|-----------------------------------|-------|
| Genişlik (mm)<br><i>Width</i>     | 20.3  |
| Yükseklik (mm)<br><i>Height</i>   | 38    |
| Gramaj (kg/mt)<br><i>Weight</i>   | 0.301 |
| Kalınlık (mm)<br><i>Thickness</i> | 0.9   |

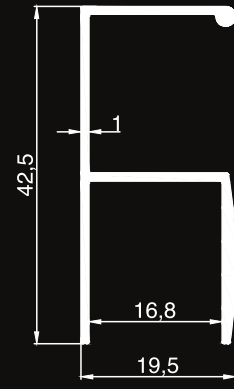



Alaşım Alüminyum

|             |                                   |       |
|-------------|-----------------------------------|-------|
| <b>2025</b> | Genişlik (mm)<br><i>Width</i>     | 16.3  |
|             | Yükseklik (mm)<br><i>Height</i>   | 34.89 |
|             | Gramaj (kg/mt)<br><i>Weight</i>   | 0.276 |
|             | Kalınlık (mm)<br><i>Thickness</i> | 1     |

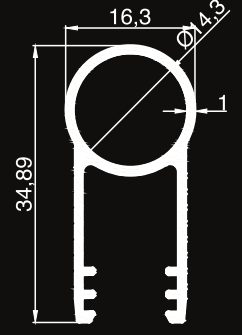

|             |                                   |       |
|-------------|-----------------------------------|-------|
| <b>2026</b> | Genişlik (mm)<br><i>Width</i>     | 36.8  |
|             | Yükseklik (mm)<br><i>Height</i>   | 29.8  |
|             | Gramaj (kg/mt)<br><i>Weight</i>   | 0.314 |
|             | Kalınlık (mm)<br><i>Thickness</i> | 0.9   |

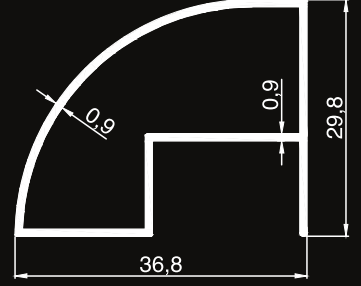

|             |                                   |       |
|-------------|-----------------------------------|-------|
| <b>2027</b> | Genişlik (mm)<br><i>Width</i>     | 35.3  |
|             | Yükseklik (mm)<br><i>Height</i>   | 22.4  |
|             | Gramaj (kg/mt)<br><i>Weight</i>   | 0.333 |
|             | Kalınlık (mm)<br><i>Thickness</i> | -     |

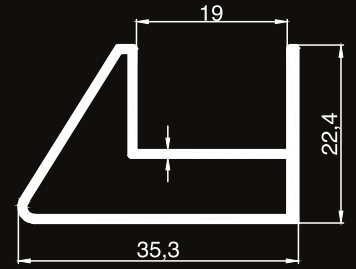

|             |  |     |
|-------------|--|-----|
| <b>2052</b> | Çevre (mm)<br><i>Perimeter</i>         | 43  |
|             | Alan (mm <sup>2</sup> )<br><i>Area</i> | 60  |
|             | Ağırlık (gr/m)<br><i>Weight</i>        | 163 |







Alaşım Alüminyum

|             |  |       |
|-------------|--|-------|
| <b>2173</b> | Çevre (mm)<br><i>Perimeter</i>         | 79,8  |
|             | Alan (mm <sup>2</sup> )<br><i>Area</i> | 109,3 |
|             | Ağırlık (gr/m)<br><i>Weight</i>        | 296   |

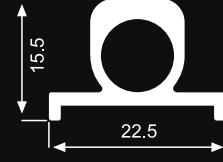

|             |  |     |
|-------------|--|-----|
| <b>2177</b> | Çevre (mm)<br><i>Perimeter</i>         | 42  |
|             | Alan (mm <sup>2</sup> )<br><i>Area</i> | 41  |
|             | Ağırlık (gr/m)<br><i>Weight</i>        | 111 |



|             |  |      |
|-------------|--|------|
| <b>2470</b> | Çevre (mm)<br><i>Perimeter</i>         | 57,7 |
|             | Alan (mm <sup>2</sup> )<br><i>Area</i> | 30,2 |
|             | Ağırlık (gr/m)<br><i>Weight</i>        | 81,8 |

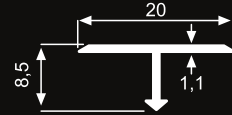

|             |  |       |
|-------------|--|-------|
| <b>2472</b> | Çevre (mm)<br><i>Perimeter</i>         | 151,2 |
|             | Alan (mm <sup>2</sup> )<br><i>Area</i> | 109,3 |
|             | Ağırlık (gr/m)<br><i>Weight</i>        | 296   |

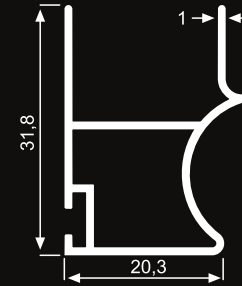

|             |  |       |
|-------------|--|-------|
| <b>2473</b> | Çevre (mm)<br><i>Perimeter</i>         | 159,2 |
|             | Alan (mm <sup>2</sup> )<br><i>Area</i> | 76,3  |
|             | Ağırlık (gr/m)<br><i>Weight</i>        | 207   |

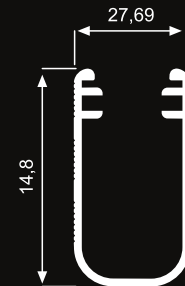



Alaşım Alüminyum

|             |  |       |
|-------------|--|-------|
| <b>2487</b> | Çevre (mm)<br><i>Perimeter</i>         | 163,8 |
|             | Alan (mm <sup>2</sup> )<br><i>Area</i> | 131,9 |
|             | Ağırlık (gr/m)<br><i>Weight</i>        | 357   |

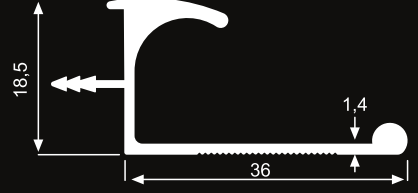

|             |  |       |
|-------------|--|-------|
| <b>2488</b> | Çevre (mm)<br><i>Perimeter</i>         | 159,4 |
|             | Alan (mm <sup>2</sup> )<br><i>Area</i> | 134   |
|             | Ağırlık (gr/m)<br><i>Weight</i>        | 363   |

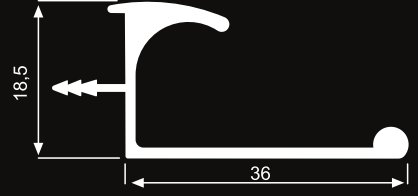

|             |  |      |
|-------------|--|------|
| <b>2489</b> | Çevre (mm)<br><i>Perimeter</i>         | 11,2 |
|             | Alan (mm <sup>2</sup> )<br><i>Area</i> | 57,8 |
|             | Ağırlık (gr/m)<br><i>Weight</i>        | 156  |

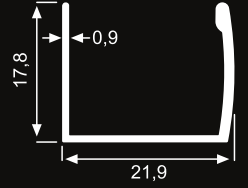

|             |  |      |
|-------------|--|------|
| <b>2490</b> | Çevre (mm)<br><i>Perimeter</i>         | 70,3 |
|             | Alan (mm <sup>2</sup> )<br><i>Area</i> | 34,5 |
|             | Ağırlık (gr/m)<br><i>Weight</i>        | 93   |

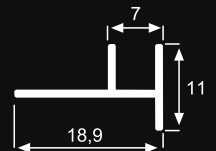



Alaşım Alüminyum

**2491**

|  |       |
|--|-------|
| Çevre (mm)<br><i>Perimeter</i>         | 255,5 |
| Alan (mm <sup>2</sup> )<br><i>Area</i> | 193,7 |
| Ağırlık (gr/m)<br><i>Weight</i>        | 525   |

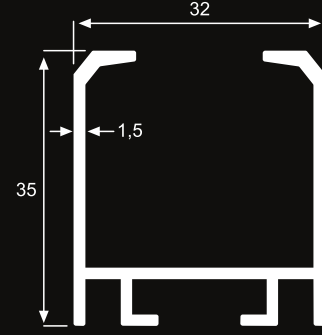

**2496**

|  |       |
|--|-------|
| Çevre (mm)<br><i>Perimeter</i>         | 190,9 |
| Alan (mm <sup>2</sup> )<br><i>Area</i> | 87,6  |
| Ağırlık (gr/m)<br><i>Weight</i>        | 237   |

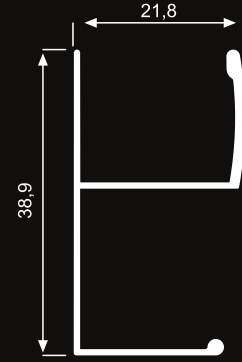

**2497**

|  |       |
|--|-------|
| Çevre (mm)<br><i>Perimeter</i>         | 165,3 |
| Alan (mm <sup>2</sup> )<br><i>Area</i> | 106,6 |
| Ağırlık (gr/m)<br><i>Weight</i>        | 289   |

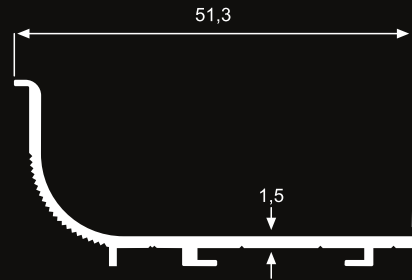

**2498**

|  |       |
|--|-------|
| Çevre (mm)<br><i>Perimeter</i>         | 243,9 |
| Alan (mm <sup>2</sup> )<br><i>Area</i> | 155,8 |
| Ağırlık (gr/m)<br><i>Weight</i>        | 422   |

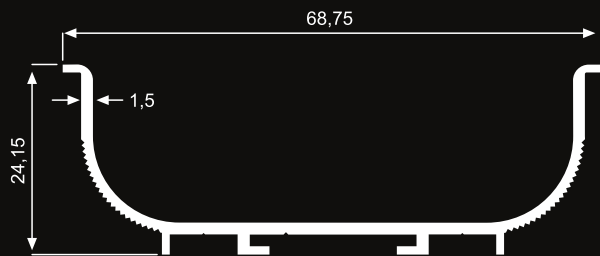



Alaşım Alüminyum

|             |  |       |
|-------------|--|-------|
| <b>2321</b> | Çevre (mm)<br><i>Perimeter</i>         | 160,3 |
|             | Alan (mm <sup>2</sup> )<br><i>Area</i> | 160,3 |
|             | Ağırlık (gr/m)<br><i>Weight</i>        | 433   |

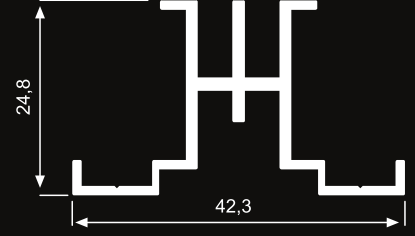

|             |  |       |
|-------------|--|-------|
| <b>2322</b> | Çevre (mm)<br><i>Perimeter</i>         | 231,4 |
|             | Alan (mm <sup>2</sup> )<br><i>Area</i> | 172,6 |
|             | Ağırlık (gr/m)<br><i>Weight</i>        | 468   |

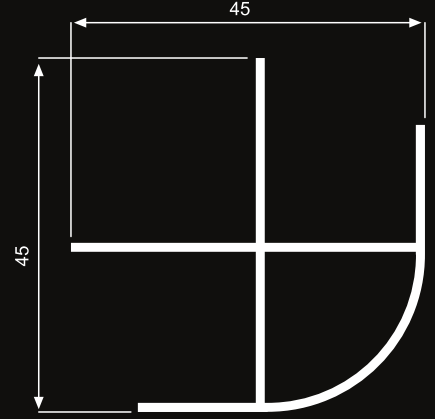

|             |  |      |
|-------------|--|------|
| <b>2323</b> | Çevre (mm)<br><i>Perimeter</i>         | 76,6 |
|             | Alan (mm <sup>2</sup> )<br><i>Area</i> | 35,7 |
|             | Ağırlık (gr/m)<br><i>Weight</i>        | 97   |

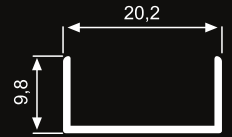

|             |  |       |
|-------------|--|-------|
| <b>2324</b> | Çevre (mm)<br><i>Perimeter</i>         | 145,8 |
|             | Alan (mm <sup>2</sup> )<br><i>Area</i> | 65,1  |
|             | Ağırlık (gr/m)<br><i>Weight</i>        | 176   |

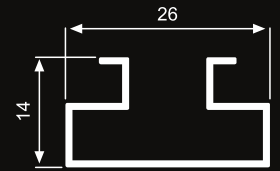



Alaşım Alüminyum

|             |  |       |
|-------------|--|-------|
| <b>1763</b> | Çevre (mm)<br><i>Perimeter</i>         | 119.4 |
|             | Alan (mm <sup>2</sup> )<br><i>Area</i> | 60.2  |
|             | Ağırlık (gr/m)<br><i>Weight</i>        | 163   |

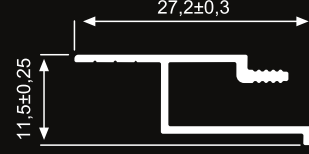

|             |  |      |
|-------------|--|------|
| <b>1759</b> | Çevre (mm)<br><i>Perimeter</i>         | 101  |
|             | Alan (mm <sup>2</sup> )<br><i>Area</i> | 47.6 |
|             | Ağırlık (gr/m)<br><i>Weight</i>        | 129  |



|             |  |     |
|-------------|--|-----|
| <b>2120</b> | Çevre (mm)<br><i>Perimeter</i>         | 103 |
|             | Alan (mm <sup>2</sup> )<br><i>Area</i> | 46  |
|             | Ağırlık (gr/m)<br><i>Weight</i>        | 125 |

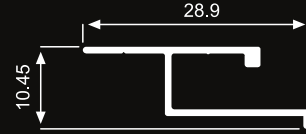

|             |  |    |
|-------------|--|----|
| <b>1886</b> | Çevre (mm)<br><i>Perimeter</i>         | 59 |
|             | Alan (mm <sup>2</sup> )<br><i>Area</i> | 33 |
|             | Ağırlık (gr/m)<br><i>Weight</i>        | 89 |

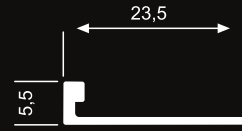

|             |  |      |
|-------------|--|------|
| <b>1788</b> | Çevre (mm)<br><i>Perimeter</i>         | 54.6 |
|             | Alan (mm <sup>2</sup> )<br><i>Area</i> | 50.3 |
|             | Ağırlık (gr/m)<br><i>Weight</i>        | 137  |

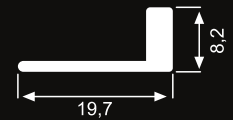



Alaşım Alüminyum

|             |  |    |
|-------------|--|----|
| <b>1858</b> | Çevre (mm)<br><i>Perimeter</i>         | 46 |
|             | Alan (mm <sup>2</sup> )<br><i>Area</i> | 31 |
|             | Ağırlık (gr/m)<br><i>Weight</i>        | 84 |

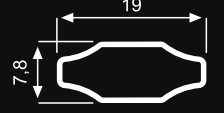

|             |  |    |
|-------------|--|----|
| <b>1878</b> | Çevre (mm)<br><i>Perimeter</i>         | 44 |
|             | Alan (mm <sup>2</sup> )<br><i>Area</i> | 25 |
|             | Ağırlık (gr/m)<br><i>Weight</i>        | 68 |

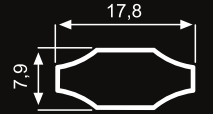

|             |  |      |
|-------------|--|------|
| <b>2427</b> | Çevre (mm)<br><i>Perimeter</i>         | 43,4 |
|             | Alan (mm <sup>2</sup> )<br><i>Area</i> | 21   |
|             | Ağırlık (gr/m)<br><i>Weight</i>        | 60   |

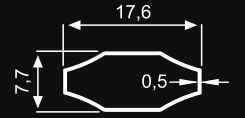

|             |  |    |
|-------------|--|----|
| <b>2104</b> | Çevre (mm)<br><i>Perimeter</i>         | 42 |
|             | Alan (mm <sup>2</sup> )<br><i>Area</i> | 32 |
|             | Ağırlık (gr/m)<br><i>Weight</i>        | 87 |

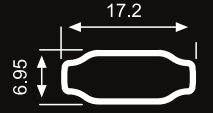

|             |  |      |
|-------------|--|------|
| <b>2202</b> | Çevre (mm)<br><i>Perimeter</i>         | 43.9 |
|             | Alan (mm <sup>2</sup> )<br><i>Area</i> | 27.2 |
|             | Ağırlık (gr/m)<br><i>Weight</i>        | 73   |

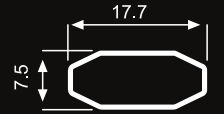

|             |  |      |
|-------------|--|------|
| <b>2417</b> | Çevre (mm)<br><i>Perimeter</i>         | 42,9 |
|             | Alan (mm <sup>2</sup> )<br><i>Area</i> | 20,7 |
|             | Ağırlık (gr/m)<br><i>Weight</i>        | 56   |

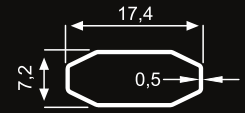

|             |  |      |
|-------------|--|------|
| <b>2429</b> | Çevre (mm)<br><i>Perimeter</i>         | 41,6 |
|             | Alan (mm <sup>2</sup> )<br><i>Area</i> | 25,7 |
|             | Ağırlık (gr/m)<br><i>Weight</i>        | 70   |

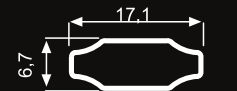



## Alaşım Alüminyum

|             |                                 |     |
|-------------|---------------------------------|-----|
| <b>1880</b> | Çevre (mm)<br>Perimeter         | 56  |
|             | Alan (mm <sup>2</sup> )<br>Area | 42  |
|             | Ağırlık (gr/m)<br>Weight        | 114 |

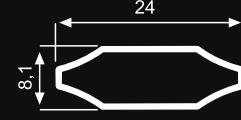

|             |                                 |     |
|-------------|---------------------------------|-----|
| <b>2251</b> | Çevre (mm)<br>Perimeter         | 60  |
|             | Alan (mm <sup>2</sup> )<br>Area | 40  |
|             | Ağırlık (gr/m)<br>Weight        | 108 |



|             |                                 |    |
|-------------|---------------------------------|----|
| <b>1881</b> | Çevre (mm)<br>Perimeter         | 28 |
|             | Alan (mm <sup>2</sup> )<br>Area | 21 |
|             | Ağırlık (gr/m)<br>Weight        | 57 |

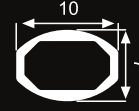

|             |                                 |    |
|-------------|---------------------------------|----|
| <b>1882</b> | Çevre (mm)<br>Perimeter         | 31 |
|             | Alan (mm <sup>2</sup> )<br>Area | 19 |
|             | Ağırlık (gr/m)<br>Weight        | 52 |

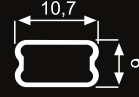

|             |                                 |    |
|-------------|---------------------------------|----|
| <b>2105</b> | Çevre (mm)<br>Perimeter         | 21 |
|             | Alan (mm <sup>2</sup> )<br>Area | 29 |
|             | Ağırlık (gr/m)<br>Weight        | 57 |

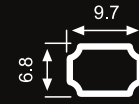

|             |                                 |    |
|-------------|---------------------------------|----|
| <b>2203</b> | Çevre (mm)<br>Perimeter         | 28 |
|             | Alan (mm <sup>2</sup> )<br>Area | 20 |
|             | Ağırlık (gr/m)<br>Weight        | 60 |

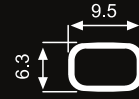

|             |                                 |    |
|-------------|---------------------------------|----|
| <b>2204</b> | Çevre (mm)<br>Perimeter         | 29 |
|             | Alan (mm <sup>2</sup> )<br>Area | 22 |
|             | Ağırlık (gr/m)<br>Weight        | 60 |



|             |                                 |      |
|-------------|---------------------------------|------|
| <b>2462</b> | Çevre (mm)<br>Perimeter         | 28,9 |
|             | Alan (mm <sup>2</sup> )<br>Area | 19,9 |
|             | Ağırlık (gr/m)<br>Weight        | 54   |

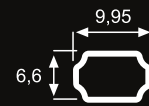



Alaşım Alüminyum

|             |  |       |
|-------------|--|-------|
| <b>1766</b> | Çevre (mm)<br><i>Perimeter</i>         | 103.4 |
|             | Alan (mm <sup>2</sup> )<br><i>Area</i> | 31.6  |
|             | Ağırlık (gr/m)<br><i>Weight</i>        | 85    |

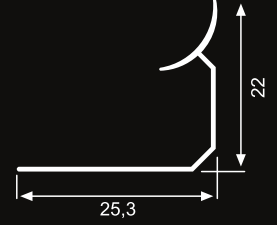

|             |  |      |
|-------------|--|------|
| <b>1767</b> | Çevre (mm)<br><i>Perimeter</i>         | 69.1 |
|             | Alan (mm <sup>2</sup> )<br><i>Area</i> | 59.6 |
|             | Ağırlık (gr/m)<br><i>Weight</i>        | 162  |

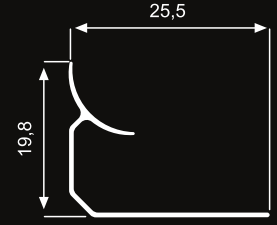

|             |  |      |
|-------------|--|------|
| <b>1768</b> | Çevre (mm)<br><i>Perimeter</i>         | 90.5 |
|             | Alan (mm <sup>2</sup> )<br><i>Area</i> | 24   |
|             | Ağırlık (gr/m)<br><i>Weight</i>        | 65   |

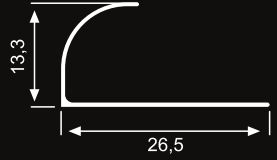

|             |  |      |
|-------------|--|------|
| <b>1769</b> | Çevre (mm)<br><i>Perimeter</i>         | 77.9 |
|             | Alan (mm <sup>2</sup> )<br><i>Area</i> | 21.5 |
|             | Ağırlık (gr/m)<br><i>Weight</i>        | 59   |

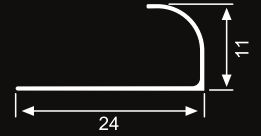

|             |  |      |
|-------------|--|------|
| <b>1770</b> | Çevre (mm)<br><i>Perimeter</i>         | 78.7 |
|             | Alan (mm <sup>2</sup> )<br><i>Area</i> | 53.3 |
|             | Ağırlık (gr/m)<br><i>Weight</i>        | 144  |

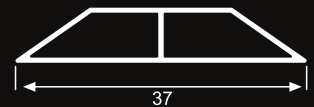





Alaşım Alüminyum

**1914**

|                                   |       |
|-----------------------------------|-------|
| Genişlik (mm)<br><i>Width</i>     | 20    |
| Yükseklik (mm)<br><i>Height</i>   | 8     |
| Gramaj (kg/mt)<br><i>Weight</i>   | 0.052 |
| Kalınlık (mm)<br><i>Thickness</i> | 0.9   |

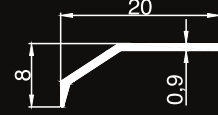

**1915**

|                                   |       |
|-----------------------------------|-------|
| Genişlik (mm)<br><i>Width</i>     | 51.9  |
| Yükseklik (mm)<br><i>Height</i>   | 29.8  |
| Gramaj (kg/mt)<br><i>Weight</i>   | 0.257 |
| Kalınlık (mm)<br><i>Thickness</i> | 1     |

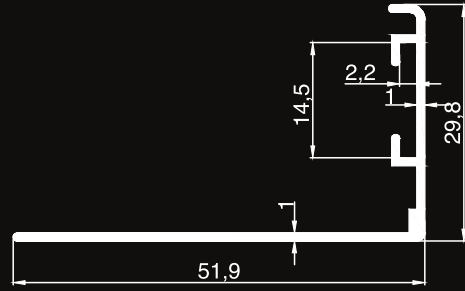

**1916**

|                                   |       |
|-----------------------------------|-------|
| Genişlik (mm)<br><i>Width</i>     | 40    |
| Yükseklik (mm)<br><i>Height</i>   | 5     |
| Gramaj (kg/mt)<br><i>Weight</i>   | 0.130 |
| Kalınlık (mm)<br><i>Thickness</i> | 1     |

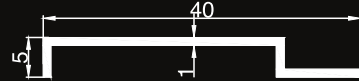

**1917**

|                                   |       |
|-----------------------------------|-------|
| Genişlik (mm)<br><i>Width</i>     | 45.5  |
| Yükseklik (mm)<br><i>Height</i>   | 73    |
| Gramaj (kg/mt)<br><i>Weight</i>   | 0.385 |
| Kalınlık (mm)<br><i>Thickness</i> | 1     |

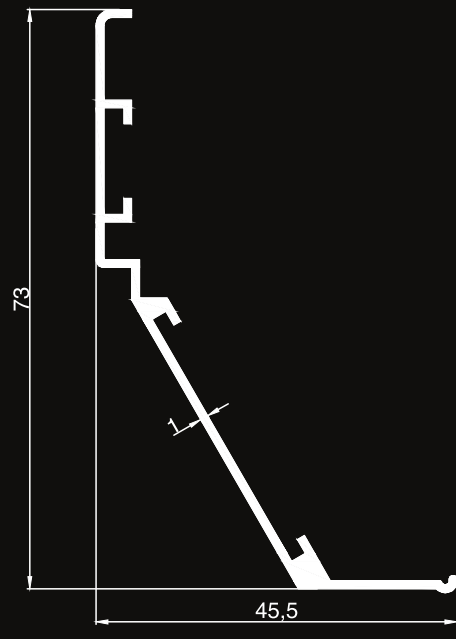

MENFEZ PROFİLLERİ  
CLIMATES PROFILES



Alaşım Alüminyum

|             |                                   |       |
|-------------|-----------------------------------|-------|
| <b>1918</b> | Genişlik (mm)<br><i>Width</i>     | 42    |
|             | Yükseklik (mm)<br><i>Height</i>   | 6.6   |
|             | Gramaj (kg/mt)<br><i>Weight</i>   | 0.130 |
|             | Kalınlık (mm)<br><i>Thickness</i> | 0.9   |

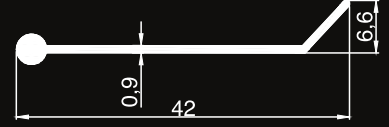

|             |                                   |       |
|-------------|-----------------------------------|-------|
| <b>1920</b> | Genişlik (mm)<br><i>Width</i>     | 29.9  |
|             | Yükseklik (mm)<br><i>Height</i>   | 29.9  |
|             | Gramaj (kg/mt)<br><i>Weight</i>   | 0.206 |
|             | Kalınlık (mm)<br><i>Thickness</i> | 1     |

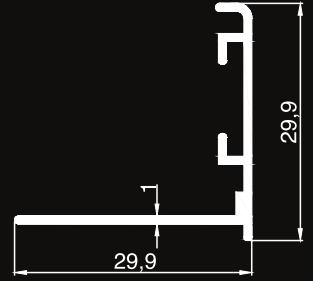

|             |                                   |       |
|-------------|-----------------------------------|-------|
| <b>1921</b> | Genişlik (mm)<br><i>Width</i>     | 15    |
|             | Yükseklik (mm)<br><i>Height</i>   | 3.8   |
|             | Gramaj (kg/mt)<br><i>Weight</i>   | 0.060 |
|             | Kalınlık (mm)<br><i>Thickness</i> | -     |



|             |                                   |       |
|-------------|-----------------------------------|-------|
| <b>1922</b> | Genişlik (mm)<br><i>Width</i>     | 29.9  |
|             | Yükseklik (mm)<br><i>Height</i>   | 29.8  |
|             | Gramaj (kg/mt)<br><i>Weight</i>   | 0.209 |
|             | Kalınlık (mm)<br><i>Thickness</i> | 1     |

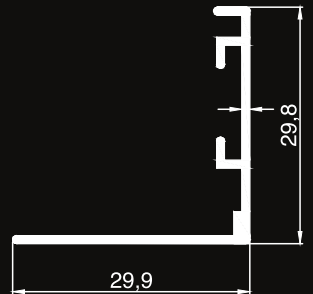



## 1923

|                                   |       |
|-----------------------------------|-------|
| Genişlik (mm)<br><i>Width</i>     | 103.5 |
| Yükseklik (mm)<br><i>Height</i>   | 17.2  |
| Gramaj (kg/mt)<br><i>Weight</i>   | 0.626 |
| Kalınlık (mm)<br><i>Thickness</i> | 1     |

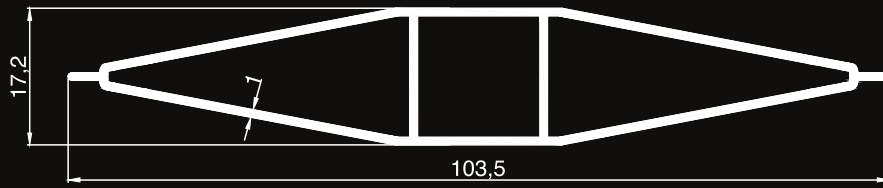

## 1925

|                                   |       |
|-----------------------------------|-------|
| Genişlik (mm)<br><i>Width</i>     | 84.25 |
| Yükseklik (mm)<br><i>Height</i>   | 12.15 |
| Gramaj (kg/mt)<br><i>Weight</i>   | 0.396 |
| Kalınlık (mm)<br><i>Thickness</i> | 0.95  |

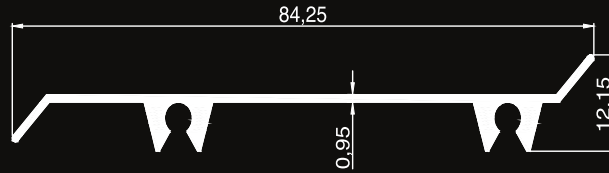

## 1934

|                                   |       |
|-----------------------------------|-------|
| Genişlik (mm)<br><i>Width</i>     | 70.5  |
| Yükseklik (mm)<br><i>Height</i>   | 26.2  |
| Gramaj (kg/mt)<br><i>Weight</i>   | 0.404 |
| Kalınlık (mm)<br><i>Thickness</i> | 1.2   |

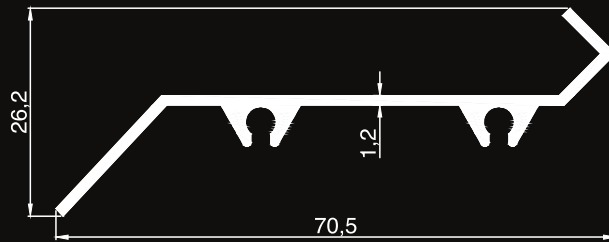

## 1919

|                                   |       |
|-----------------------------------|-------|
| Genişlik (mm)<br><i>Width</i>     | 54.14 |
| Yükseklik (mm)<br><i>Height</i>   | 16.6  |
| Gramaj (kg/mt)<br><i>Weight</i>   | 0.203 |
| Kalınlık (mm)<br><i>Thickness</i> | 1     |

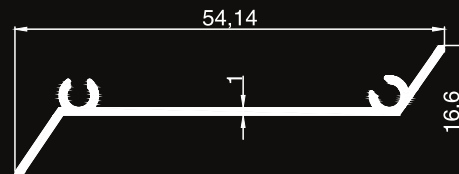



Alaşım Alüminyum

**1924**

|                                   |       |
|-----------------------------------|-------|
| Genişlik (mm)<br><i>Width</i>     | 119.4 |
| Yükseklik (mm)<br><i>Height</i>   | 2.15  |
| Gramaj (kg/mt)<br><i>Weight</i>   | 1.172 |
| Kalınlık (mm)<br><i>Thickness</i> | 1.4   |

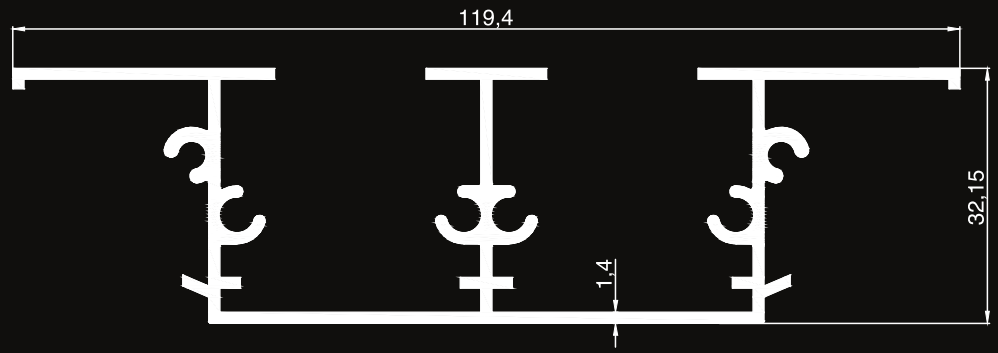

**1927**

|                                   |       |
|-----------------------------------|-------|
| Genişlik (mm)<br><i>Width</i>     | 153.7 |
| Yükseklik (mm)<br><i>Height</i>   | 32.15 |
| Gramaj (kg/mt)<br><i>Weight</i>   | 1.629 |
| Kalınlık (mm)<br><i>Thickness</i> | 1.4   |

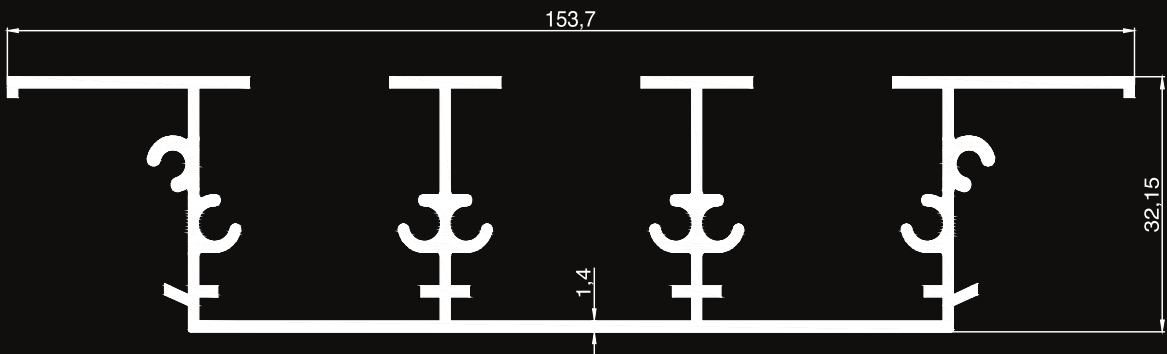

**1926**

|                                   |       |
|-----------------------------------|-------|
| Genişlik (mm)<br><i>Width</i>     | 22.8  |
| Yükseklik (mm)<br><i>Height</i>   | 30.32 |
| Gramaj (kg/mt)<br><i>Weight</i>   | 0.169 |
| Kalınlık (mm)<br><i>Thickness</i> | 0.9   |

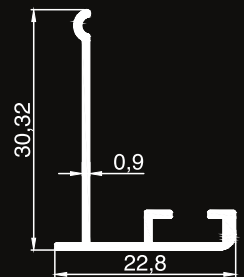



Alaşım Alüminyum

**1930**

|                                   |       |
|-----------------------------------|-------|
| Genişlik (mm)<br><i>Width</i>     | 35.41 |
| Yükseklik (mm)<br><i>Height</i>   | 30.85 |
| Gramaj (kg/mt)<br><i>Weight</i>   | 0.230 |
| Kalınlık (mm)<br><i>Thickness</i> | 0.9   |

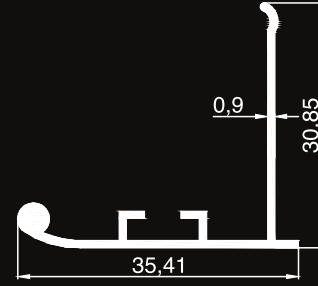

**1928**

|                                   |       |
|-----------------------------------|-------|
| Genişlik (mm)<br><i>Width</i>     | 27.7  |
| Yükseklik (mm)<br><i>Height</i>   | 21    |
| Gramaj (kg/mt)<br><i>Weight</i>   | 0.247 |
| Kalınlık (mm)<br><i>Thickness</i> | 1.2   |

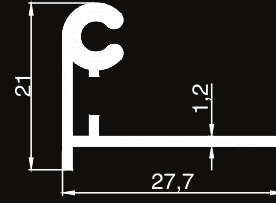

**1929**

|                                   |       |
|-----------------------------------|-------|
| Genişlik (mm)<br><i>Width</i>     | 51.83 |
| Yükseklik (mm)<br><i>Height</i>   | 32    |
| Gramaj (kg/mt)<br><i>Weight</i>   | 0.282 |
| Kalınlık (mm)<br><i>Thickness</i> | 1     |

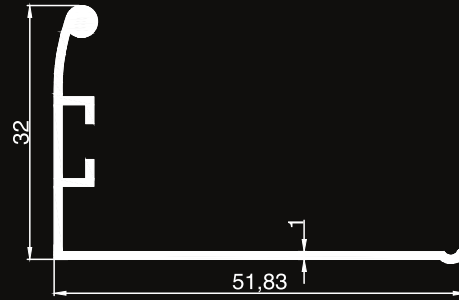

**1931**

|                                   |       |
|-----------------------------------|-------|
| Genişlik (mm)<br><i>Width</i>     | 32.61 |
| Yükseklik (mm)<br><i>Height</i>   | 30.85 |
| Gramaj (kg/mt)<br><i>Weight</i>   | 0.228 |
| Kalınlık (mm)<br><i>Thickness</i> | 0.9   |

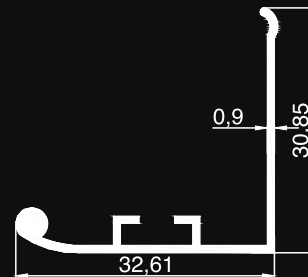

MENFEZ PROFİLLERİ  
CLIMATES PROFILES



Alaşım Alüminyum

**1932**

|                                   |       |
|-----------------------------------|-------|
| Genişlik (mm)<br><i>Width</i>     | 70    |
| Yükseklik (mm)<br><i>Height</i>   | 45    |
| Gramaj (kg/mt)<br><i>Weight</i>   | 0.761 |
| Kalınlık (mm)<br><i>Thickness</i> | 1.3   |

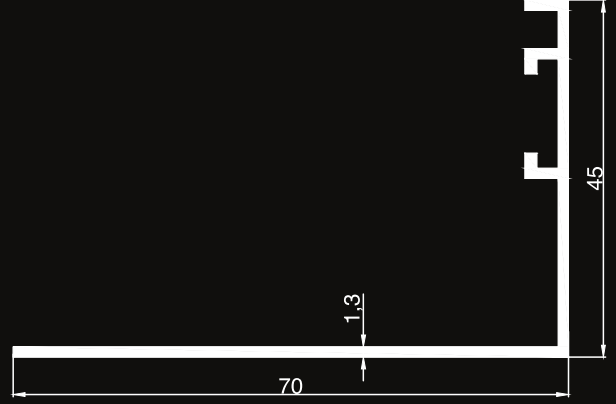

**1933**

|                                   |       |
|-----------------------------------|-------|
| Genişlik (mm)<br><i>Width</i>     | 47    |
| Yükseklik (mm)<br><i>Height</i>   | 47    |
| Gramaj (kg/mt)<br><i>Weight</i>   | 0.396 |
| Kalınlık (mm)<br><i>Thickness</i> | 1     |

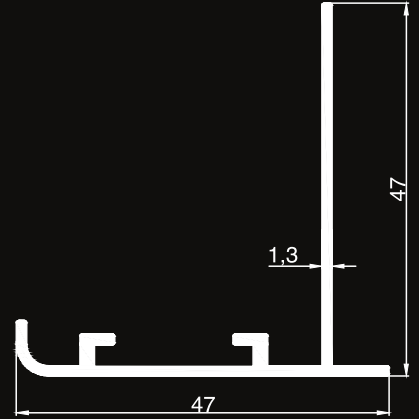

**1935**

|                                   |       |
|-----------------------------------|-------|
| Genişlik (mm)<br><i>Width</i>     | 7     |
| Yükseklik (mm)<br><i>Height</i>   | 5     |
| Gramaj (kg/mt)<br><i>Weight</i>   | 0.052 |
| Kalınlık (mm)<br><i>Thickness</i> | 1     |



**1936**

|                                   |       |
|-----------------------------------|-------|
| Genişlik (mm)<br><i>Width</i>     | 10    |
| Yükseklik (mm)<br><i>Height</i>   | 8     |
| Gramaj (kg/mt)<br><i>Weight</i>   | 0.076 |
| Kalınlık (mm)<br><i>Thickness</i> | 1     |





Alaşım Alüminyum

**1937**

|                                   |       |
|-----------------------------------|-------|
| Genişlik (mm)<br><i>Width</i>     | 80    |
| Yükseklik (mm)<br><i>Height</i>   | 50    |
| Gramaj (kg/mt)<br><i>Weight</i>   | 0.482 |
| Kalınlık (mm)<br><i>Thickness</i> | 1.1   |

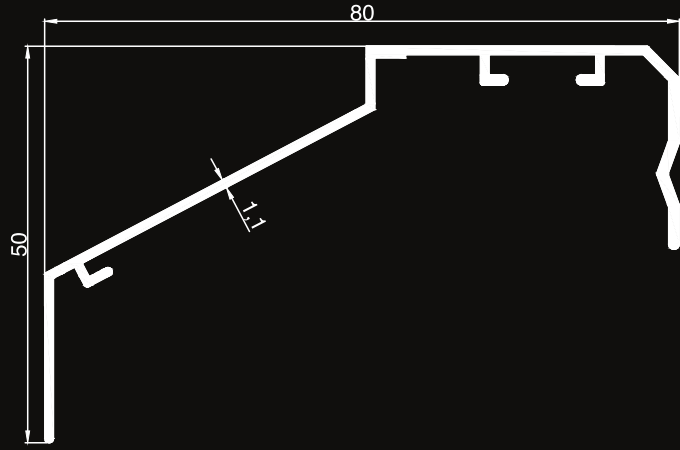

**1938**

|                                   |       |
|-----------------------------------|-------|
| Genişlik (mm)<br><i>Width</i>     | 110   |
| Yükseklik (mm)<br><i>Height</i>   | 25    |
| Gramaj (kg/mt)<br><i>Weight</i>   | 0.558 |
| Kalınlık (mm)<br><i>Thickness</i> | 1.2   |



**1939**

|                                   |       |
|-----------------------------------|-------|
| Genişlik (mm)<br><i>Width</i>     | 110   |
| Yükseklik (mm)<br><i>Height</i>   | 25    |
| Gramaj (kg/mt)<br><i>Weight</i>   | 0.772 |
| Kalınlık (mm)<br><i>Thickness</i> | 1.2   |

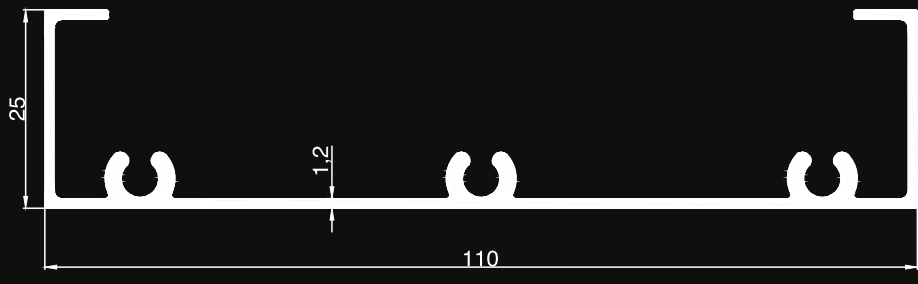

MENFEZ PROFİLLERİ  
CLIMATES PROFILES



Alaşım Alüminyum

**1940**

|                                   |       |
|-----------------------------------|-------|
| Genişlik (mm)<br><i>Width</i>     | 80    |
| Yükseklik (mm)<br><i>Height</i>   | 50    |
| Gramaj (kg/mt)<br><i>Weight</i>   | 0.482 |
| Kalınlık (mm)<br><i>Thickness</i> | 1.1   |

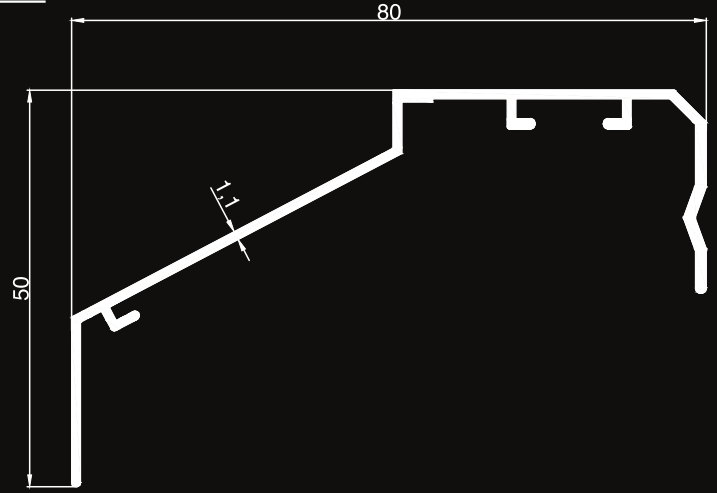

**1941**

|                                   |       |
|-----------------------------------|-------|
| Genişlik (mm)<br><i>Width</i>     | 30    |
| Yükseklik (mm)<br><i>Height</i>   | 25    |
| Gramaj (kg/mt)<br><i>Weight</i>   | 0.515 |
| Kalınlık (mm)<br><i>Thickness</i> | 1.5   |

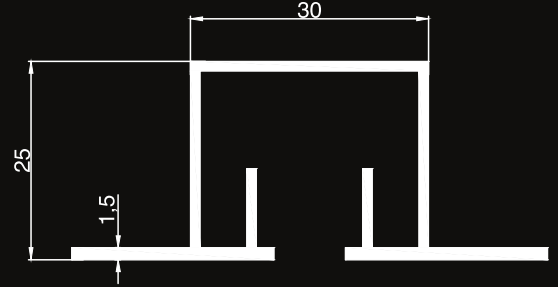

**1942**

|                                   |       |
|-----------------------------------|-------|
| Genişlik (mm)<br><i>Width</i>     | 110   |
| Yükseklik (mm)<br><i>Height</i>   | 25    |
| Gramaj (kg/mt)<br><i>Weight</i>   | 0.558 |
| Kalınlık (mm)<br><i>Thickness</i> | 1.2   |

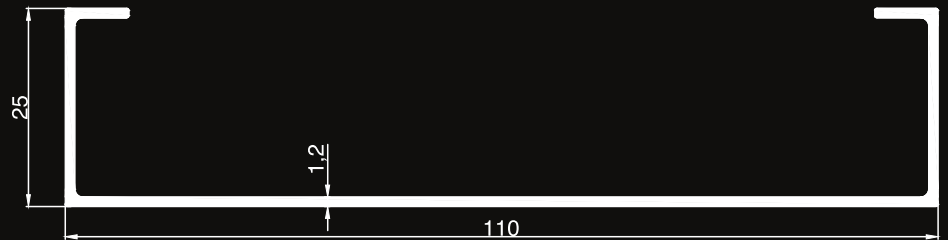





Alaşım Alüminyum

**1944**

|                                   |       |
|-----------------------------------|-------|
| Genişlik (mm)<br><i>Width</i>     | 103   |
| Yükseklik (mm)<br><i>Height</i>   | 18.8  |
| Gramaj (kg/mt)<br><i>Weight</i>   | 0.729 |
| Kalınlık (mm)<br><i>Thickness</i> | 1.4   |

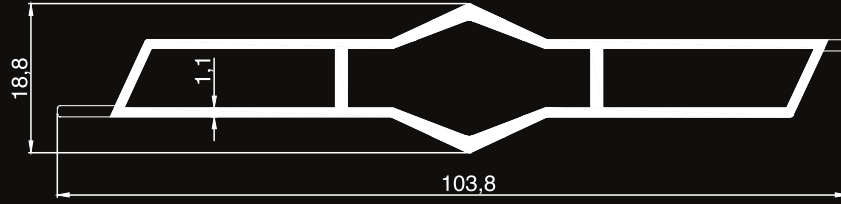

**1850**

|                                   |       |
|-----------------------------------|-------|
| Genişlik (mm)<br><i>Width</i>     | 25    |
| Yükseklik (mm)<br><i>Height</i>   | 35    |
| Gramaj (kg/mt)<br><i>Weight</i>   | 0.252 |
| Kalınlık (mm)<br><i>Thickness</i> | 1.2   |

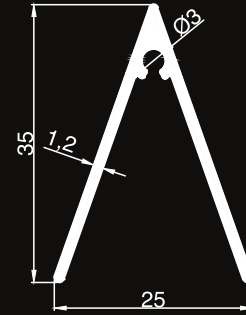

**1946**

|                                   |       |
|-----------------------------------|-------|
| Genişlik (mm)<br><i>Width</i>     | 48.5  |
| Yükseklik (mm)<br><i>Height</i>   | 24.7  |
| Gramaj (kg/mt)<br><i>Weight</i>   | 0.252 |
| Kalınlık (mm)<br><i>Thickness</i> | 1.1   |

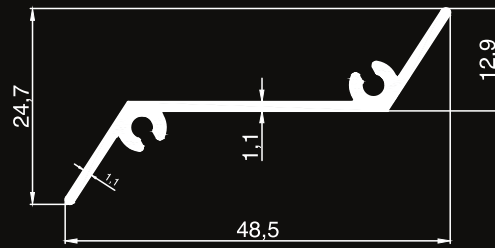

**1947**

|                                   |       |
|-----------------------------------|-------|
| Genişlik (mm)<br><i>Width</i>     | 68.7  |
| Yükseklik (mm)<br><i>Height</i>   | 45.35 |
| Gramaj (kg/mt)<br><i>Weight</i>   | 0.816 |
| Kalınlık (mm)<br><i>Thickness</i> | 1.4   |

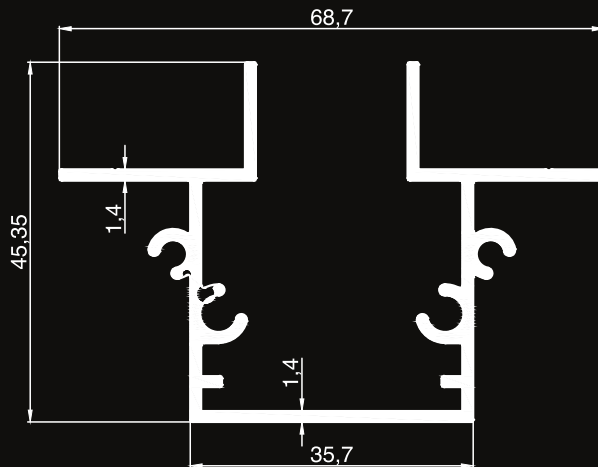

MENFEZ PROFİLLERİ  
CLIMATES PROFILES



Alaşım Alüminyum

**1948**

|                                   |       |
|-----------------------------------|-------|
| Genişlik (mm)<br><i>Width</i>     | 4.99  |
| Yükseklik (mm)<br><i>Height</i>   | 18    |
| Gramaj (kg/mt)<br><i>Weight</i>   | 0.125 |
| Kalınlık (mm)<br><i>Thickness</i> | 2.22  |

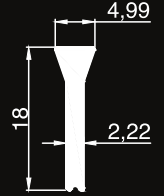

**1949**

|                                   |       |
|-----------------------------------|-------|
| Genişlik (mm)<br><i>Width</i>     | 38.5  |
| Yükseklik (mm)<br><i>Height</i>   | 20    |
| Gramaj (kg/mt)<br><i>Weight</i>   | 0.252 |
| Kalınlık (mm)<br><i>Thickness</i> | 1.2   |

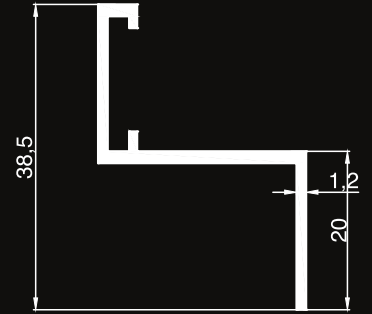

**1955**

|                                   |       |
|-----------------------------------|-------|
| Genişlik (mm)<br><i>Width</i>     | 19.7  |
| Yükseklik (mm)<br><i>Height</i>   | 4.3   |
| Gramaj (kg/mt)<br><i>Weight</i>   | 0.100 |
| Kalınlık (mm)<br><i>Thickness</i> | 1.4   |



**1956**

|                                   |       |
|-----------------------------------|-------|
| Genişlik (mm)<br><i>Width</i>     | 20    |
| Yükseklik (mm)<br><i>Height</i>   | 4.3   |
| Gramaj (kg/mt)<br><i>Weight</i>   | 0.106 |
| Kalınlık (mm)<br><i>Thickness</i> | 1.3   |

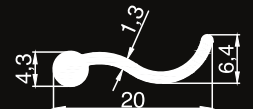



Alaşım Alüminyum

**1943**

|                                   |       |
|-----------------------------------|-------|
| Genişlik (mm)<br><i>Width</i>     | 44    |
| Yükseklik (mm)<br><i>Height</i>   | 38.8  |
| Gramaj (kg/mt)<br><i>Weight</i>   | 0.268 |
| Kalınlık (mm)<br><i>Thickness</i> | 1.4   |

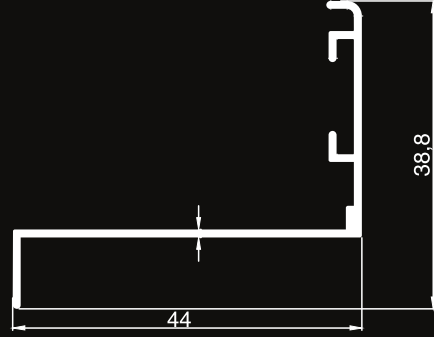

**1950**

|                                   |       |
|-----------------------------------|-------|
| Genişlik (mm)<br><i>Width</i>     | 13.7  |
| Yükseklik (mm)<br><i>Height</i>   | 103.8 |
| Gramaj (kg/mt)<br><i>Weight</i>   | 0.683 |
| Kalınlık (mm)<br><i>Thickness</i> | 1.1   |



**1953**

|                                   |       |
|-----------------------------------|-------|
| Genişlik (mm)<br><i>Width</i>     | 4.99  |
| Yükseklik (mm)<br><i>Height</i>   | 18    |
| Gramaj (kg/mt)<br><i>Weight</i>   | 0.125 |
| Kalınlık (mm)<br><i>Thickness</i> | 2.22  |

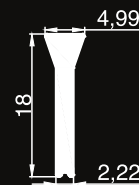

MENFEZ PROFİLLERİ  
CLIMATES PROFILES



Alaşım Alüminyum

**1949**

|                                   |       |
|-----------------------------------|-------|
| Genişlik (mm)<br><i>Width</i>     | 38.5  |
| Yükseklik (mm)<br><i>Height</i>   | 20    |
| Gramaj (kg/mt)<br><i>Weight</i>   | 0.252 |
| Kalınlık (mm)<br><i>Thickness</i> | 1.2   |

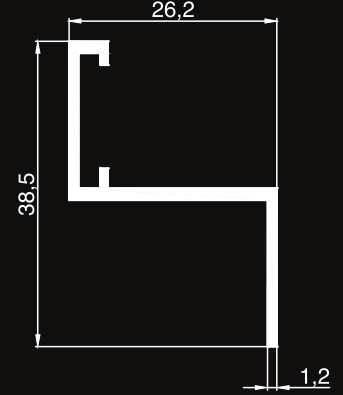

**1951**

|                                   |       |
|-----------------------------------|-------|
| Genişlik (mm)<br><i>Width</i>     | 19.7  |
| Yükseklik (mm)<br><i>Height</i>   | 4.3   |
| Gramaj (kg/mt)<br><i>Weight</i>   | 0.100 |
| Kalınlık (mm)<br><i>Thickness</i> | 1.4   |

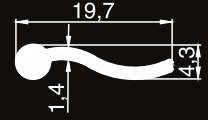

**1952**

|                                   |       |
|-----------------------------------|-------|
| Genişlik (mm)<br><i>Width</i>     | 20    |
| Yükseklik (mm)<br><i>Height</i>   | 4.3   |
| Gramaj (kg/mt)<br><i>Weight</i>   | 0.106 |
| Kalınlık (mm)<br><i>Thickness</i> | 1.3   |

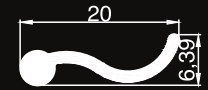

**1957**

|                                   |       |
|-----------------------------------|-------|
| Genişlik (mm)<br><i>Width</i>     | 20    |
| Yükseklik (mm)<br><i>Height</i>   | 16    |
| Gramaj (kg/mt)<br><i>Weight</i>   | 0.222 |
| Kalınlık (mm)<br><i>Thickness</i> | 1     |

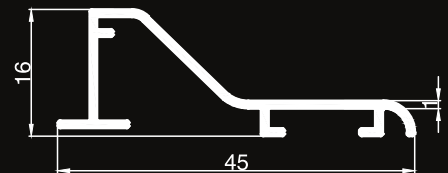



## 1958

|                                   |       |
|-----------------------------------|-------|
| Genişlik (mm)<br><i>Width</i>     | 17.9  |
| Yükseklik (mm)<br><i>Height</i>   | 4.4   |
| Gramaj (kg/mt)<br><i>Weight</i>   | 0.087 |
| Kalınlık (mm)<br><i>Thickness</i> | 1.5   |

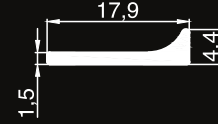

## 1959

|                                   |       |
|-----------------------------------|-------|
| Genişlik (mm)<br><i>Width</i>     | 49    |
| Yükseklik (mm)<br><i>Height</i>   | 4.9   |
| Gramaj (kg/mt)<br><i>Weight</i>   | 0.209 |
| Kalınlık (mm)<br><i>Thickness</i> | 1     |



## 1960

|                                   |       |
|-----------------------------------|-------|
| Genişlik (mm)<br><i>Width</i>     | 32.4  |
| Yükseklik (mm)<br><i>Height</i>   | 31    |
| Gramaj (kg/mt)<br><i>Weight</i>   | 0.225 |
| Kalınlık (mm)<br><i>Thickness</i> | 1.1   |

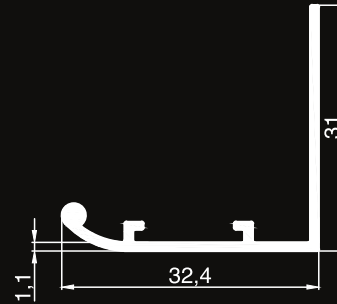

## 1961

|                                   |       |
|-----------------------------------|-------|
| Genişlik (mm)<br><i>Width</i>     | 46.8  |
| Yükseklik (mm)<br><i>Height</i>   | 32.4  |
| Gramaj (kg/mt)<br><i>Weight</i>   | 0.271 |
| Kalınlık (mm)<br><i>Thickness</i> | 1.1   |

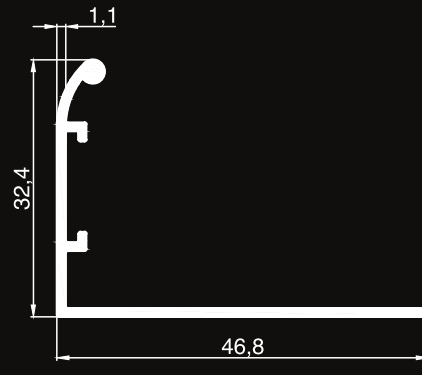



Alaşım Alüminyum

**1962**

|                                   |       |
|-----------------------------------|-------|
| Genişlik (mm)<br><i>Width</i>     | 60    |
| Yükseklik (mm)<br><i>Height</i>   | 43.4  |
| Gramaj (kg/mt)<br><i>Weight</i>   | 0.347 |
| Kalınlık (mm)<br><i>Thickness</i> | 1.1   |

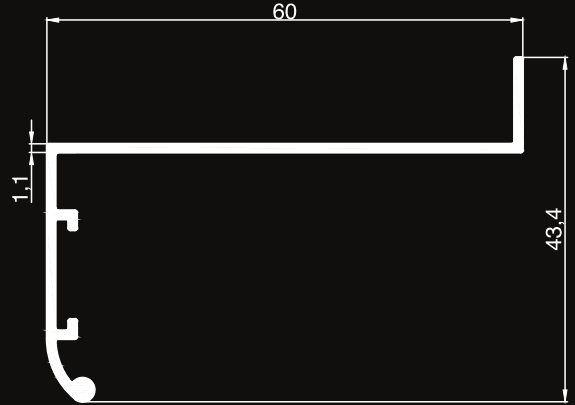

**1963**

|                                   |       |
|-----------------------------------|-------|
| Genişlik (mm)<br><i>Width</i>     | 74    |
| Yükseklik (mm)<br><i>Height</i>   | 40.21 |
| Gramaj (kg/mt)<br><i>Weight</i>   | 0.396 |
| Kalınlık (mm)<br><i>Thickness</i> | 1.2   |

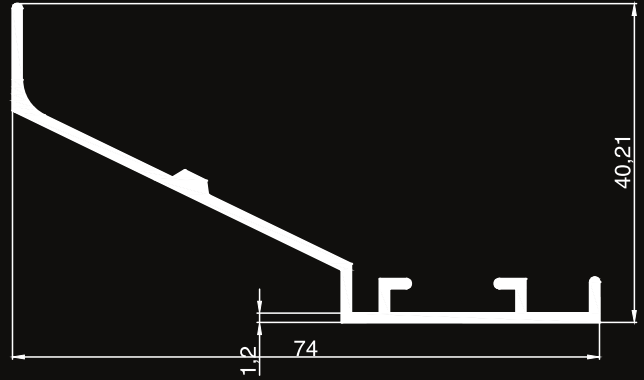

**1964**

|                                   |       |
|-----------------------------------|-------|
| Genişlik (mm)<br><i>Width</i>     | 12    |
| Yükseklik (mm)<br><i>Height</i>   | 2     |
| Gramaj (kg/mt)<br><i>Weight</i>   | 0.065 |
| Kalınlık (mm)<br><i>Thickness</i> | 2     |

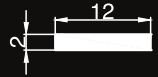

**1965**

|                                   |       |
|-----------------------------------|-------|
| Genişlik (mm)<br><i>Width</i>     | 60.18 |
| Yükseklik (mm)<br><i>Height</i>   | 15.4  |
| Gramaj (kg/mt)<br><i>Weight</i>   | 0.182 |
| Kalınlık (mm)<br><i>Thickness</i> | 0.6   |

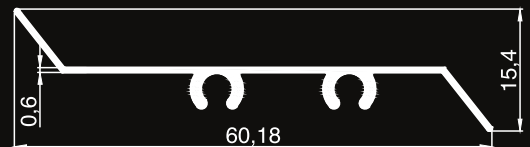



## 1966

|                                   |       |
|-----------------------------------|-------|
| Genişlik (mm)<br><i>Width</i>     | 48.2  |
| Yükseklik (mm)<br><i>Height</i>   | 30.1  |
| Gramaj (kg/mt)<br><i>Weight</i>   | 0.455 |
| Kalınlık (mm)<br><i>Thickness</i> | 1.1   |

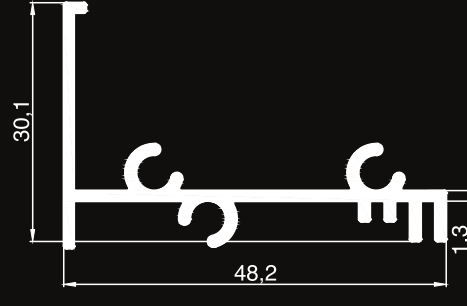

## 1967

|                                   |       |
|-----------------------------------|-------|
| Genişlik (mm)<br><i>Width</i>     | 13.13 |
| Yükseklik (mm)<br><i>Height</i>   | 48.2  |
| Gramaj (kg/mt)<br><i>Weight</i>   | 0.442 |
| Kalınlık (mm)<br><i>Thickness</i> | 1.3   |

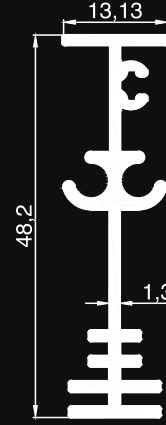

## 1968

|                                   |       |
|-----------------------------------|-------|
| Genişlik (mm)<br><i>Width</i>     | 42    |
| Yükseklik (mm)<br><i>Height</i>   | 16    |
| Gramaj (kg/mt)<br><i>Weight</i>   | 0.220 |
| Kalınlık (mm)<br><i>Thickness</i> | 1     |

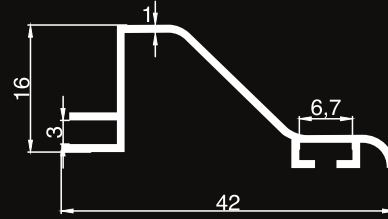

## 1969

|                                   |       |
|-----------------------------------|-------|
| Genişlik (mm)<br><i>Width</i>     | 31.85 |
| Yükseklik (mm)<br><i>Height</i>   | 52    |
| Gramaj (kg/mt)<br><i>Weight</i>   | 0.276 |
| Kalınlık (mm)<br><i>Thickness</i> | 1.1   |

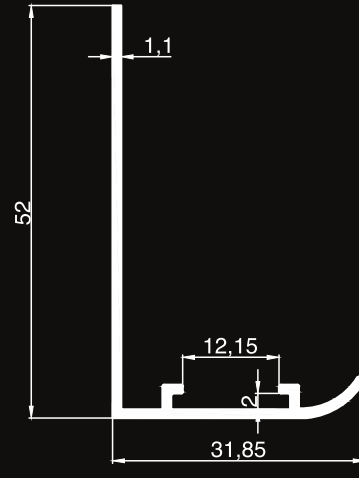



Alaşım Alüminyum

|             |                                   |       |
|-------------|-----------------------------------|-------|
| <b>1970</b> | Genişlik (mm)<br><i>Width</i>     | 49    |
|             | Yükseklik (mm)<br><i>Height</i>   | 29.4  |
|             | Gramaj (kg/mt)<br><i>Weight</i>   | 0.366 |
|             | Kalınlık (mm)<br><i>Thickness</i> | 1.2   |
|             |                                   |       |

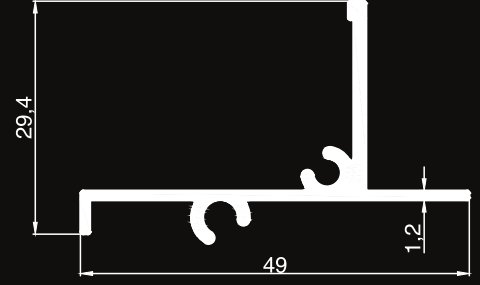

|             |                                   |       |
|-------------|-----------------------------------|-------|
| <b>1971</b> | Genişlik (mm)<br><i>Width</i>     | 41    |
|             | Yükseklik (mm)<br><i>Height</i>   | 3.65  |
|             | Gramaj (kg/mt)<br><i>Weight</i>   | 0.103 |
|             | Kalınlık (mm)<br><i>Thickness</i> | 0.7   |
|             |                                   |       |

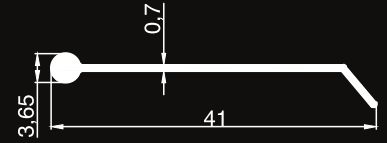

|             |                                   |       |
|-------------|-----------------------------------|-------|
| <b>1972</b> | Genişlik (mm)<br><i>Width</i>     | 80    |
|             | Yükseklik (mm)<br><i>Height</i>   | 20    |
|             | Gramaj (kg/mt)<br><i>Weight</i>   | 0.686 |
|             | Kalınlık (mm)<br><i>Thickness</i> | 1.4   |
|             |                                   |       |

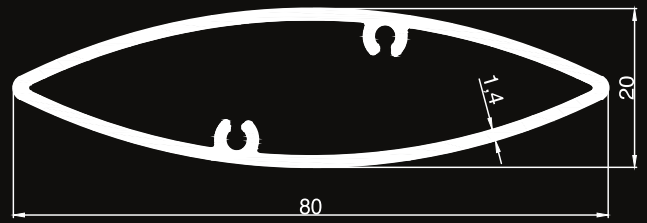

|             |                                   |       |
|-------------|-----------------------------------|-------|
| <b>1973</b> | Genişlik (mm)<br><i>Width</i>     | 22    |
|             | Yükseklik (mm)<br><i>Height</i>   | 25    |
|             | Gramaj (kg/mt)<br><i>Weight</i>   | 0.249 |
|             | Kalınlık (mm)<br><i>Thickness</i> | 0.9   |
|             |                                   |       |

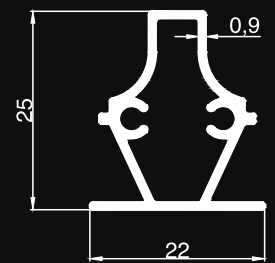





Alaşım Alüminyum

**1974**

|                                   |       |
|-----------------------------------|-------|
| Genişlik (mm)<br><i>Width</i>     | 23.5  |
| Yükseklik (mm)<br><i>Height</i>   | 22.2  |
| Gramaj (kg/mt)<br><i>Weight</i>   | 0.176 |
| Kalınlık (mm)<br><i>Thickness</i> | 0.9   |

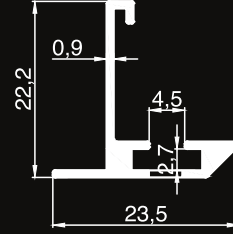

**1975**

|                                   |       |
|-----------------------------------|-------|
| Genişlik (mm)<br><i>Width</i>     | 89    |
| Yükseklik (mm)<br><i>Height</i>   | 25    |
| Gramaj (kg/mt)<br><i>Weight</i>   | 1.222 |
| Kalınlık (mm)<br><i>Thickness</i> | 1.3   |

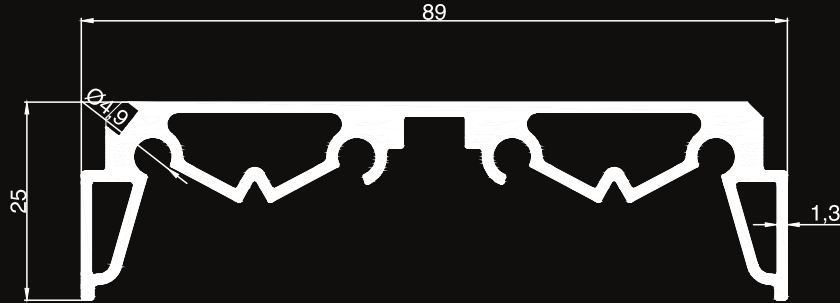

**1976**

|                                   |       |
|-----------------------------------|-------|
| Genişlik (mm)<br><i>Width</i>     | 19    |
| Yükseklik (mm)<br><i>Height</i>   | 4.3   |
| Gramaj (kg/mt)<br><i>Weight</i>   | 0.087 |
| Kalınlık (mm)<br><i>Thickness</i> | 1.1   |

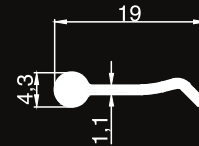

**1977**

|                                   |       |
|-----------------------------------|-------|
| Genişlik (mm)<br><i>Width</i>     | 64.7  |
| Yükseklik (mm)<br><i>Height</i>   | 43.92 |
| Gramaj (kg/mt)<br><i>Weight</i>   | 0.417 |
| Kalınlık (mm)<br><i>Thickness</i> | 1.1   |

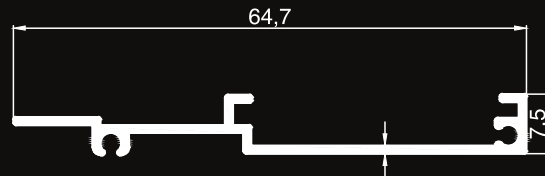

MENFEZ PROFİLLERİ  
CLIMATES PROFILES



Alaşım Alüminyum

**1978**

|                                   |       |
|-----------------------------------|-------|
| Genişlik (mm)<br><i>Width</i>     | 77.2  |
| Yükseklik (mm)<br><i>Height</i>   | 43.92 |
| Gramaj (kg/mt)<br><i>Weight</i>   | 0.417 |
| Kalınlık (mm)<br><i>Thickness</i> | 1.1   |

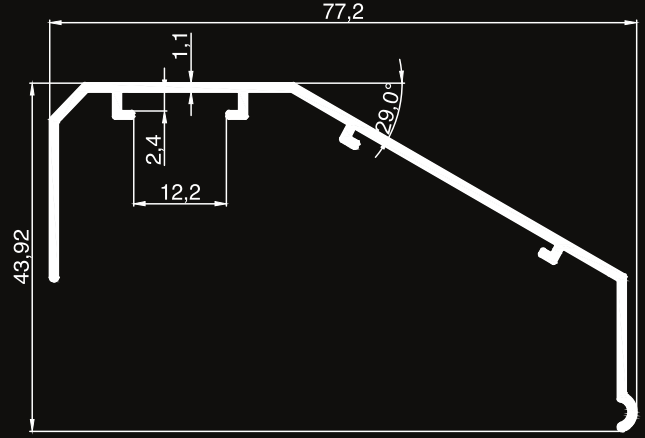

**1979**

|                                   |     |
|-----------------------------------|-----|
| Genişlik (mm)<br><i>Width</i>     | --- |
| Yükseklik (mm)<br><i>Height</i>   | --- |
| Gramaj (kg/mt)<br><i>Weight</i>   | --- |
| Kalınlık (mm)<br><i>Thickness</i> | --- |

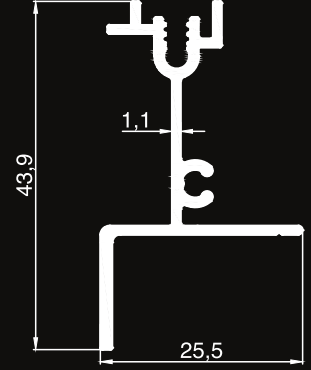

**1980**

|                                   |       |
|-----------------------------------|-------|
| Genişlik (mm)<br><i>Width</i>     | 38.3  |
| Yükseklik (mm)<br><i>Height</i>   | 20    |
| Gramaj (kg/mt)<br><i>Weight</i>   | 0.225 |
| Kalınlık (mm)<br><i>Thickness</i> | 1     |

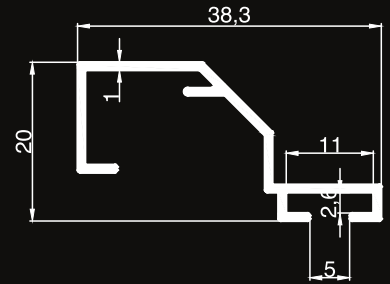

**1981**

|                                   |       |
|-----------------------------------|-------|
| Genişlik (mm)<br><i>Width</i>     | 18    |
| Yükseklik (mm)<br><i>Height</i>   | 8.5   |
| Gramaj (kg/mt)<br><i>Weight</i>   | 0.187 |
| Kalınlık (mm)<br><i>Thickness</i> | -     |

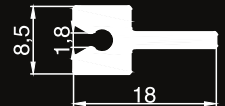



## 1982

|                                   |       |
|-----------------------------------|-------|
| Genişlik (mm)<br><i>Width</i>     | 13.5  |
| Yükseklik (mm)<br><i>Height</i>   | 5     |
| Gramaj (kg/mt)<br><i>Weight</i>   | 0.060 |
| Kalınlık (mm)<br><i>Thickness</i> | 1.6   |

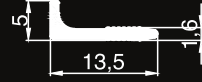

## 1983

|                                   |       |
|-----------------------------------|-------|
| Genişlik (mm)<br><i>Width</i>     | 15.6  |
| Yükseklik (mm)<br><i>Height</i>   | 24    |
| Gramaj (kg/mt)<br><i>Weight</i>   | 0.127 |
| Kalınlık (mm)<br><i>Thickness</i> | 1     |

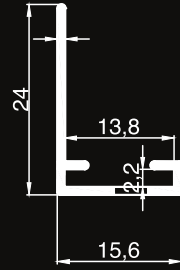

## 1984

|                                   |       |
|-----------------------------------|-------|
| Genişlik (mm)<br><i>Width</i>     | 40.7  |
| Yükseklik (mm)<br><i>Height</i>   | 32.6  |
| Gramaj (kg/mt)<br><i>Weight</i>   | 0.358 |
| Kalınlık (mm)<br><i>Thickness</i> | 1.3   |

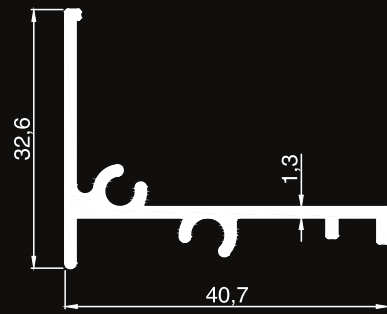

## 1985

|                |       |
|----------------|-------|
| Genişlik (mm)  | 40.7  |
| Yükseklik (mm) | 14    |
| Gramaj (kg/mt) | 0.298 |
| Kalınlık (mm)  | 1.3   |

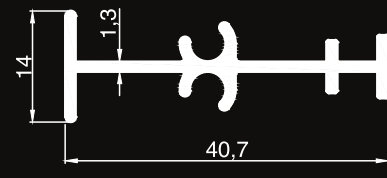



Alaşım Alüminyum

**1986**

|                                   |       |
|-----------------------------------|-------|
| Genişlik (mm)<br><i>Width</i>     | 30.8  |
| Yükseklik (mm)<br><i>Height</i>   | 30    |
| Gramaj (kg/mt)<br><i>Weight</i>   | 0.206 |
| Kalınlık (mm)<br><i>Thickness</i> | 1.1   |

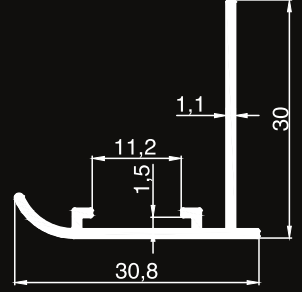

**1987**

|                                   |       |
|-----------------------------------|-------|
| Genişlik (mm)<br><i>Width</i>     | 22.2  |
| Yükseklik (mm)<br><i>Height</i>   | 52    |
| Gramaj (kg/mt)<br><i>Weight</i>   | 0.255 |
| Kalınlık (mm)<br><i>Thickness</i> | 1.1   |

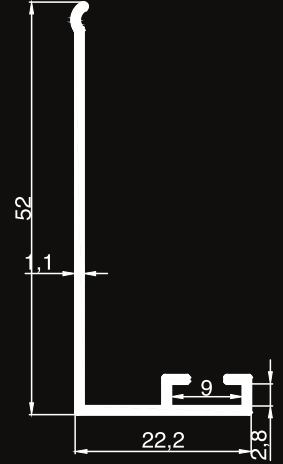

**1988**

|                                   |       |
|-----------------------------------|-------|
| Genişlik (mm)<br><i>Width</i>     | 22.2  |
| Yükseklik (mm)<br><i>Height</i>   | 28    |
| Gramaj (kg/mt)<br><i>Weight</i>   | 0.184 |
| Kalınlık (mm)<br><i>Thickness</i> | 1.1   |

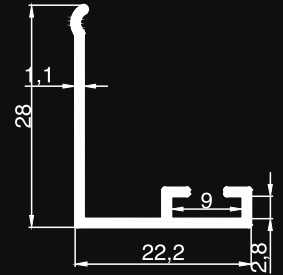

**1989**

|                                   |       |
|-----------------------------------|-------|
| Genişlik (mm)<br><i>Width</i>     | 29    |
| Yükseklik (mm)<br><i>Height</i>   | 7     |
| Gramaj (kg/mt)<br><i>Weight</i>   | 0.098 |
| Kalınlık (mm)<br><i>Thickness</i> | 0.9   |

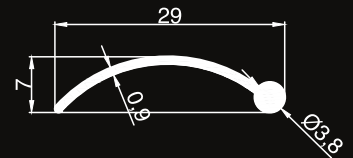



|             |  |      |
|-------------|--|------|
| <b>1848</b> | Çevre (mm)<br><i>Perimeter</i>         | 90.8 |
|             | Alan (mm <sup>2</sup> )<br><i>Area</i> | 37.5 |
|             | Ağırlık (gr/m)<br><i>Weight</i>        | 102  |

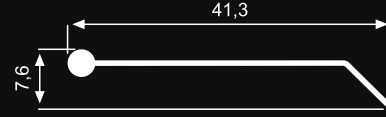

|             |  |       |
|-------------|--|-------|
| <b>1849</b> | Çevre (mm)<br><i>Perimeter</i>         | 152.7 |
|             | Alan (mm <sup>2</sup> )<br><i>Area</i> | 84.1  |
|             | Ağırlık (gr/m)<br><i>Weight</i>        | 228   |

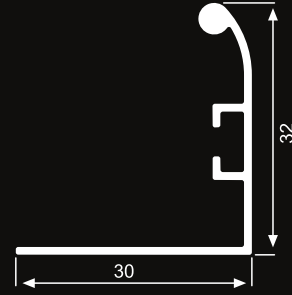

|             |  |      |
|-------------|--|------|
| <b>1850</b> | Çevre (mm)<br><i>Perimeter</i>         | 38.9 |
|             | Alan (mm <sup>2</sup> )<br><i>Area</i> | 29.4 |
|             | Ağırlık (gr/m)<br><i>Weight</i>        | 80   |



|             |  |       |
|-------------|--|-------|
| <b>1851</b> | Çevre (mm)<br><i>Perimeter</i>         | 123.1 |
|             | Alan (mm <sup>2</sup> )<br><i>Area</i> | 85.9  |
|             | Ağırlık (gr/m)<br><i>Weight</i>        | 233   |

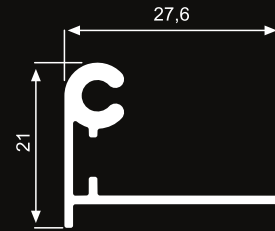

|             |  |       |
|-------------|--|-------|
| <b>1852</b> | Çevre (mm)<br><i>Perimeter</i>         | 192.7 |
|             | Alan (mm <sup>2</sup> )<br><i>Area</i> | 104.1 |
|             | Ağırlık (gr/m)<br><i>Weight</i>        | 282   |





Alaşım Alüminyum

|             |  |       |
|-------------|--|-------|
| <b>2069</b> | Çevre (mm)<br><i>Perimeter</i>         | 159.8 |
|             | Alan (mm <sup>2</sup> )<br><i>Area</i> | 80.7  |
|             | Ağırlık (gr/m)<br><i>Weight</i>        | 218   |



|             |  |     |
|-------------|--|-----|
| <b>2118</b> | Çevre (mm)<br><i>Perimeter</i>         | 177 |
|             | Alan (mm <sup>2</sup> )<br><i>Area</i> | 89  |
|             | Ağırlık (gr/m)<br><i>Weight</i>        | 241 |

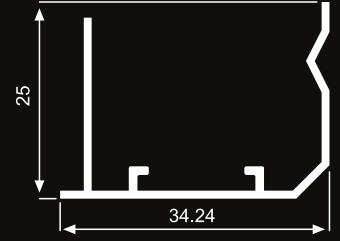



Alaşım Alüminyum

|             |                                 |      |
|-------------|---------------------------------|------|
| <b>1803</b> | Çevre (mm)<br>Perimeter         | 86   |
|             | Alan (mm <sup>2</sup> )<br>Area | 70.2 |
|             | Ağırlık (gr/m)<br>Weight        | 191  |

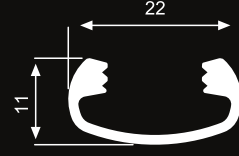

|             |                                 |      |
|-------------|---------------------------------|------|
| <b>1837</b> | Çevre (mm)<br>Perimeter         | 94.3 |
|             | Alan (mm <sup>2</sup> )<br>Area | 49.3 |
|             | Ağırlık (gr/m)<br>Weight        | 134  |

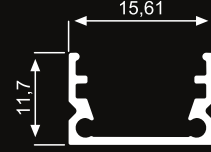

|             |                                 |      |
|-------------|---------------------------------|------|
| <b>2128</b> | Çevre (mm)<br>Perimeter         | 59.7 |
|             | Alan (mm <sup>2</sup> )<br>Area | 36.8 |
|             | Ağırlık (gr/m)<br>Weight        | 99.7 |

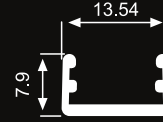

|             |                                 |       |
|-------------|---------------------------------|-------|
| <b>2129</b> | Çevre (mm)<br>Perimeter         | 96.8  |
|             | Alan (mm <sup>2</sup> )<br>Area | 51.4  |
|             | Ağırlık (gr/m)<br>Weight        | 140.6 |

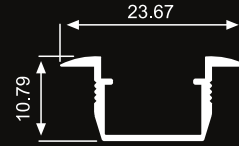

|             |                                 |       |
|-------------|---------------------------------|-------|
| <b>2435</b> | Çevre (mm)<br>Perimeter         | 92,7  |
|             | Alan (mm <sup>2</sup> )<br>Area | 38,3  |
|             | Ağırlık (gr/m)<br>Weight        | 103,8 |

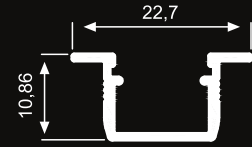

|             |                                 |     |
|-------------|---------------------------------|-----|
| <b>2284</b> | Çevre (mm)<br>Perimeter         | 61  |
|             | Alan (mm <sup>2</sup> )<br>Area | 50  |
|             | Ağırlık (gr/m)<br>Weight        | 136 |

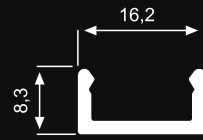

|             |                                 |      |
|-------------|---------------------------------|------|
| <b>2131</b> | Çevre (mm)<br>Perimeter         | 45.8 |
|             | Alan (mm <sup>2</sup> )<br>Area | 25.9 |
|             | Ağırlık (gr/m)<br>Weight        | 70.2 |

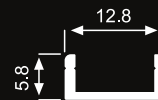



Alaşım Alüminyum

|             |  |      |
|-------------|--|------|
| <b>2133</b> | Çevre (mm)<br><i>Perimeter</i>         | 88   |
|             | Alan (mm <sup>2</sup> )<br><i>Area</i> | 30.2 |
|             | Ağırlık (gr/m)<br><i>Weight</i>        | 81.8 |

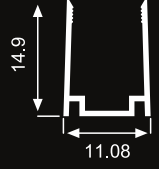

|             |  |      |
|-------------|--|------|
| <b>2140</b> | Çevre (mm)<br><i>Perimeter</i>         | 75.6 |
|             | Alan (mm <sup>2</sup> )<br><i>Area</i> | 34.2 |
|             | Ağırlık (gr/m)<br><i>Weight</i>        | 92.7 |

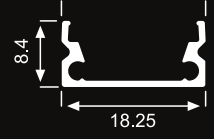

|             |  |      |
|-------------|--|------|
| <b>2155</b> | Çevre (mm)<br><i>Perimeter</i>         | 99.8 |
|             | Alan (mm <sup>2</sup> )<br><i>Area</i> | 62   |
|             | Ağırlık (gr/m)<br><i>Weight</i>        | 162  |

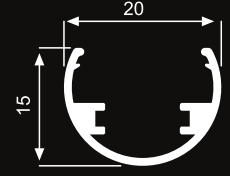

|             |  |      |
|-------------|--|------|
| <b>2130</b> | Çevre (mm)<br><i>Perimeter</i>         | 97.8 |
|             | Alan (mm <sup>2</sup> )<br><i>Area</i> | 62   |
|             | Ağırlık (gr/m)<br><i>Weight</i>        | 168  |

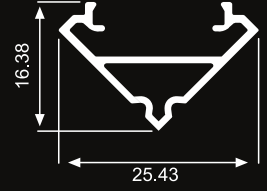

|             |  |      |
|-------------|--|------|
| <b>2278</b> | Çevre (mm)<br><i>Perimeter</i>         | 81.2 |
|             | Alan (mm <sup>2</sup> )<br><i>Area</i> | 63.5 |
|             | Ağırlık (gr/m)<br><i>Weight</i>        | 172  |

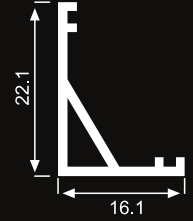

|             |  |       |
|-------------|--|-------|
| <b>2225</b> | Çevre (mm)<br><i>Perimeter</i>         | 141.8 |
|             | Alan (mm <sup>2</sup> )<br><i>Area</i> | 94.2  |
|             | Ağırlık (gr/m)<br><i>Weight</i>        | 255   |

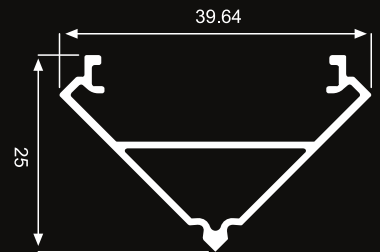





Alaşım Alüminyum

|             |                                 |      |
|-------------|---------------------------------|------|
| <b>2226</b> | Çevre (mm)<br>Perimeter         | 99   |
|             | Alan (mm <sup>2</sup> )<br>Area | 44.6 |
|             | Ağırlık (gr/m)<br>Weight        | 120  |



|             |                                 |     |
|-------------|---------------------------------|-----|
| <b>2227</b> | Çevre (mm)<br>Perimeter         | 80  |
|             | Alan (mm <sup>2</sup> )<br>Area | 54  |
|             | Ağırlık (gr/m)<br>Weight        | 146 |



|             |                                 |     |
|-------------|---------------------------------|-----|
| <b>2228</b> | Çevre (mm)<br>Perimeter         | 103 |
|             | Alan (mm <sup>2</sup> )<br>Area | 41  |
|             | Ağırlık (gr/m)<br>Weight        | 111 |

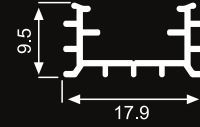

|             |                                 |      |
|-------------|---------------------------------|------|
| <b>2229</b> | Çevre (mm)<br>Perimeter         | 27.1 |
|             | Alan (mm <sup>2</sup> )<br>Area | 23.7 |
|             | Ağırlık (gr/m)<br>Weight        | 64   |

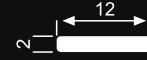

|             |                                 |      |
|-------------|---------------------------------|------|
| <b>2230</b> | Çevre (mm)<br>Perimeter         | 83.5 |
|             | Alan (mm <sup>2</sup> )<br>Area | 41.5 |
|             | Ağırlık (gr/m)<br>Weight        | 112  |

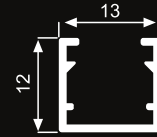

|             |                                 |      |
|-------------|---------------------------------|------|
| <b>1861</b> | Çevre (mm)<br>Perimeter         | 89   |
|             | Alan (mm <sup>2</sup> )<br>Area | 88.6 |
|             | Ağırlık (gr/m)<br>Weight        | 240  |



|             |                                 |       |
|-------------|---------------------------------|-------|
| <b>2146</b> | Çevre (mm)<br>Perimeter         | 102.3 |
|             | Alan (mm <sup>2</sup> )<br>Area | 182.3 |
|             | Ağırlık (gr/m)<br>Weight        | 494   |

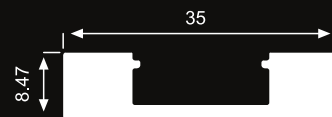



Alaşım Alüminyum

|             |  |      |
|-------------|--|------|
| <b>2301</b> | Çevre (mm)<br><i>Perimeter</i>         | 80,1 |
|             | Alan (mm <sup>2</sup> )<br><i>Area</i> | 63,2 |
|             | Ağırlık (gr/m)<br><i>Weight</i>        | 171  |

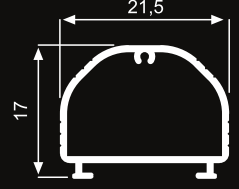

|             |  |       |
|-------------|--|-------|
| <b>2302</b> | Çevre (mm)<br><i>Perimeter</i>         | 145,2 |
|             | Alan (mm <sup>2</sup> )<br><i>Area</i> | 108,6 |
|             | Ağırlık (gr/m)<br><i>Weight</i>        | 294   |

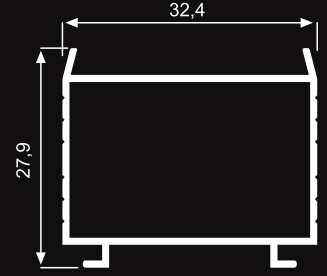

|             |  |      |
|-------------|--|------|
| <b>2469</b> | Çevre (mm)<br><i>Perimeter</i>         | 57   |
|             | Alan (mm <sup>2</sup> )<br><i>Area</i> | 37,2 |
|             | Ağırlık (gr/m)<br><i>Weight</i>        | 104  |

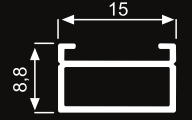

|             |  |      |
|-------------|--|------|
| <b>2460</b> | Çevre (mm)<br><i>Perimeter</i>         | 57,6 |
|             | Alan (mm <sup>2</sup> )<br><i>Area</i> | 55   |
|             | Ağırlık (gr/m)<br><i>Weight</i>        | 149  |

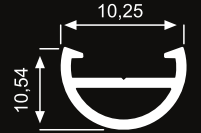

|             |  |       |
|-------------|--|-------|
| <b>2471</b> | Çevre (mm)<br><i>Perimeter</i>         | 78    |
|             | Alan (mm <sup>2</sup> )<br><i>Area</i> | 38,3  |
|             | Ağırlık (gr/m)<br><i>Weight</i>        | 103,8 |

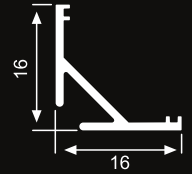

|             |  |      |
|-------------|--|------|
| <b>2492</b> | Çevre (mm)<br><i>Perimeter</i>         | 60,2 |
|             | Alan (mm <sup>2</sup> )<br><i>Area</i> | 27,6 |
|             | Ağırlık (gr/m)<br><i>Weight</i>        | 74,8 |

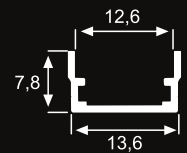



Alaşım Alüminyum

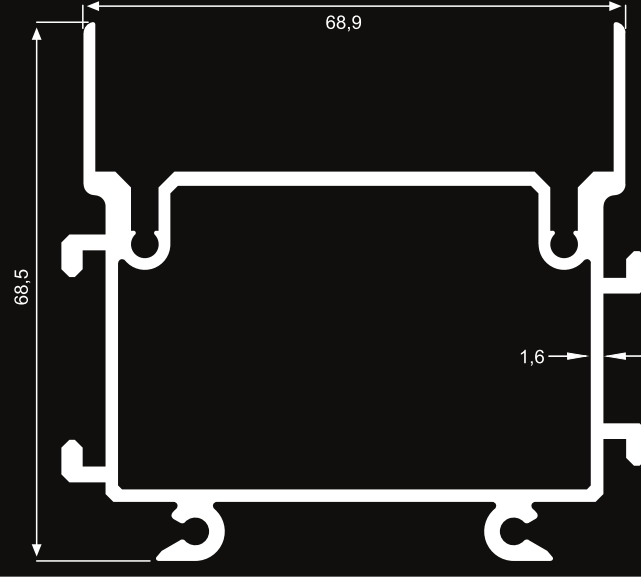

**2395**

\* Özel üründür

|                                 |       |
|---------------------------------|-------|
| Çevre (mm)<br>Perimeter         | 451,7 |
| Alan (mm <sup>2</sup> )<br>Area | 608,2 |
| Ağırlık (gr/m)<br>Weight        | 1648  |

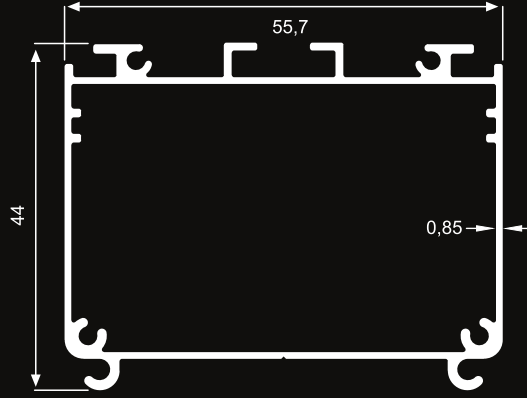

**2430**

|                                 |       |
|---------------------------------|-------|
| Çevre (mm)<br>Perimeter         | 278   |
| Alan (mm <sup>2</sup> )<br>Area | 242,1 |
| Ağırlık (gr/m)<br>Weight        | 656   |

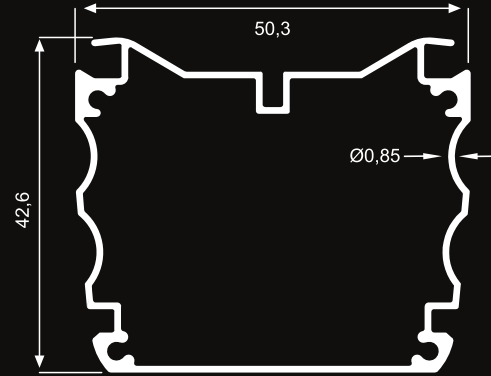

**2439**

\* Özel üründür

|                                 |       |
|---------------------------------|-------|
| Çevre (mm)<br>Perimeter         | 220,8 |
| Alan (mm <sup>2</sup> )<br>Area | 212,9 |
| Ağırlık (gr/m)<br>Weight        | 576   |

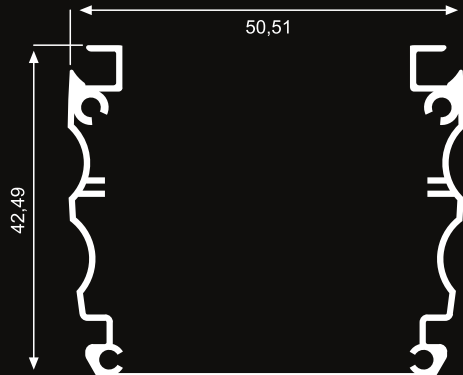

**2448**

\* Özel üründür

|                                 |       |
|---------------------------------|-------|
| Çevre (mm)<br>Perimeter         | 372,8 |
| Alan (mm <sup>2</sup> )<br>Area | 169,9 |
| Ağırlık (gr/m)<br>Weight        | 460   |



Alaşım Alüminyum

|                |                                 |       |
|----------------|---------------------------------|-------|
| <b>1842</b>    | Çevre (mm)<br>Perimeter         | 127.1 |
| * Özel üründür | Alan (mm <sup>2</sup> )<br>Area | 76.5  |
|                | Ağırlık (gr/m)<br>Weight        | 207   |



|                |                                 |     |
|----------------|---------------------------------|-----|
| <b>1843</b>    | Çevre (mm)<br>Perimeter         | 479 |
| * Özel üründür | Alan (mm <sup>2</sup> )<br>Area | 316 |
|                | Ağırlık (gr/m)<br>Weight        | 856 |

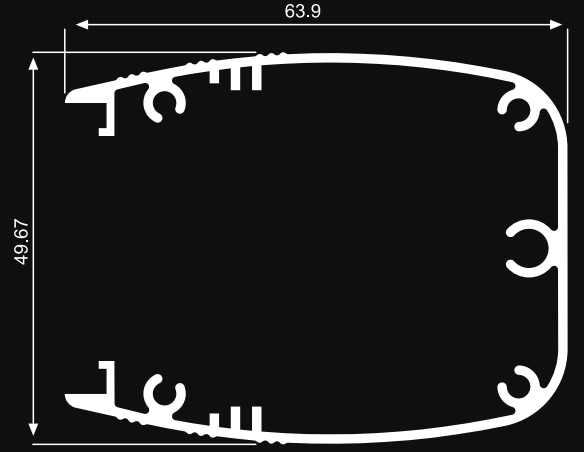

|             |                                 |       |
|-------------|---------------------------------|-------|
| <b>2196</b> | Çevre (mm)<br>Perimeter         | 465.6 |
|             | Alan (mm <sup>2</sup> )<br>Area | 333.8 |
|             | Ağırlık (gr/m)<br>Weight        | 905   |

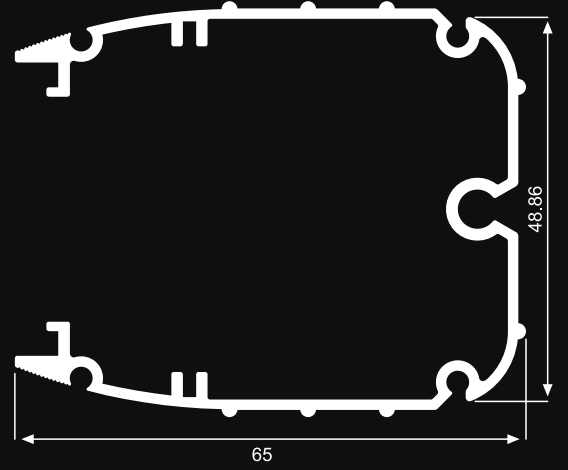

|             |                                 |       |
|-------------|---------------------------------|-------|
| <b>2197</b> | Çevre (mm)<br>Perimeter         | 122.4 |
|             | Alan (mm <sup>2</sup> )<br>Area | 77.9  |
|             | Ağırlık (gr/m)<br>Weight        | 211   |

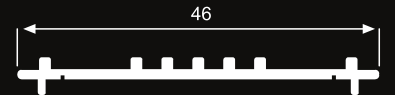



Alaşım Alüminyum

**2114**

Çevre (mm)  
Perimeter

353.8

\* Özel üründür

Alan (mm<sup>2</sup>)  
Area

351.8

Ağırlık (gr/m)  
Weight

953

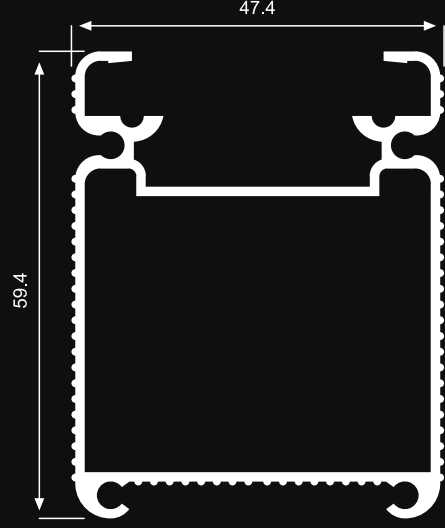

**2115**

Çevre (mm)  
Perimeter

22.2

\* Özel üründür

Alan (mm<sup>2</sup>)  
Area

20.9

Ağırlık (gr/m)  
Weight

57



**1863**

Çevre (mm)  
Perimeter

511.6

Alan (mm<sup>2</sup>)  
Area

398.8

Ağırlık (gr/m)  
Weight

1081

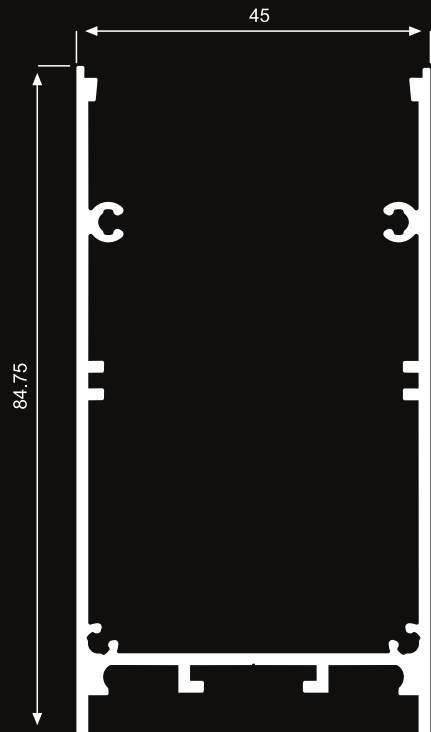



Alaşım Alüminyum

|             |                                 |        |
|-------------|---------------------------------|--------|
| <b>2132</b> | Çevre (mm)<br>Perimeter         | 399.6  |
|             | Alan (mm <sup>2</sup> )<br>Area | 446    |
|             | Ağırlık (gr/m)<br>Weight        | 1208.7 |

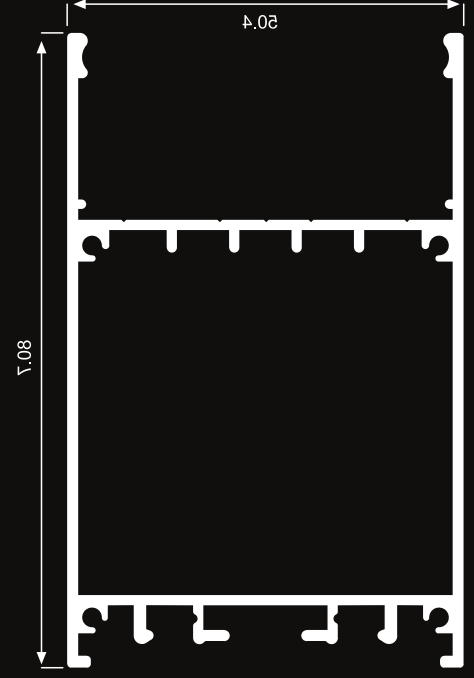

|             |                                 |       |
|-------------|---------------------------------|-------|
| <b>2147</b> | Çevre (mm)<br>Perimeter         | 567.6 |
|             | Alan (mm <sup>2</sup> )<br>Area | 404.2 |
|             | Ağırlık (gr/m)<br>Weight        | 1095  |

\* Özel üründür

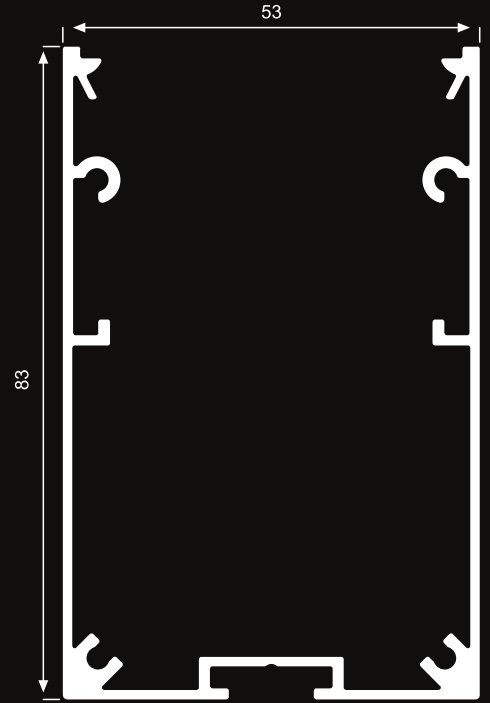

|             |                                 |      |
|-------------|---------------------------------|------|
| <b>2148</b> | Çevre (mm)<br>Perimeter         | 125  |
|             | Alan (mm <sup>2</sup> )<br>Area | 61.2 |
|             | Ağırlık (gr/m)<br>Weight        | 166  |

\* Özel üründür





Alaşım Alüminyum

**2182**

|  |      |
|--|------|
| Çevre (mm)<br><i>Perimeter</i>         | 385  |
| Alan (mm <sup>2</sup> )<br><i>Area</i> | 431  |
| Ağırlık (gr/m)<br><i>Weight</i>        | 1168 |

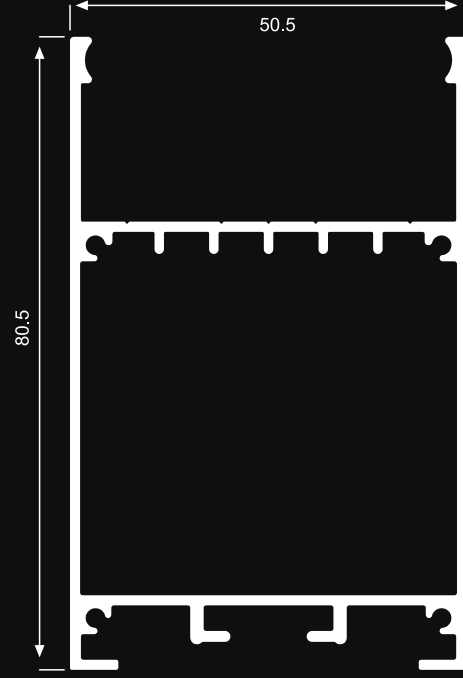

**2055**

|  |       |
|--|-------|
| Çevre (mm)<br><i>Perimeter</i>         | 611.4 |
| Alan (mm <sup>2</sup> )<br><i>Area</i> | 432   |
| Ağırlık (gr/m)<br><i>Weight</i>        | 1171  |

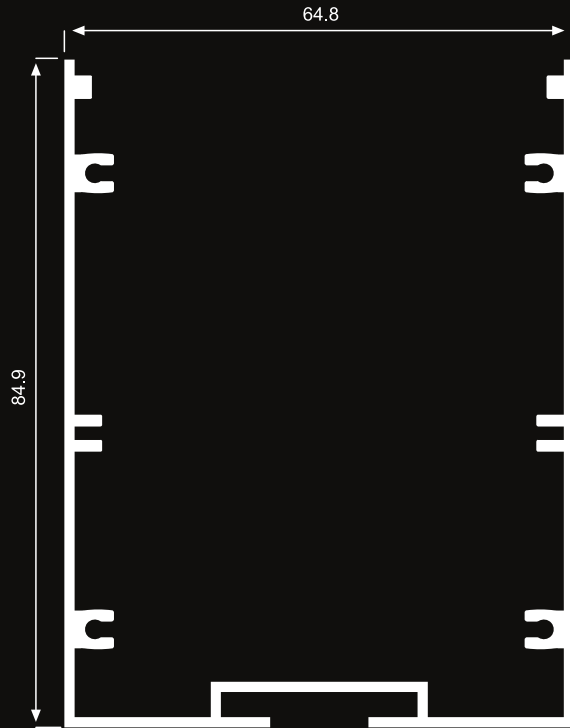



Alaşım Alüminyum

**2300**

|  |       |
|--|-------|
| Çevre (mm)<br><i>Perimeter</i>         | 389,3 |
| Alan (mm <sup>2</sup> )<br><i>Area</i> | 355,6 |
| Ağırlık (gr/m)<br><i>Weight</i>        | 964   |

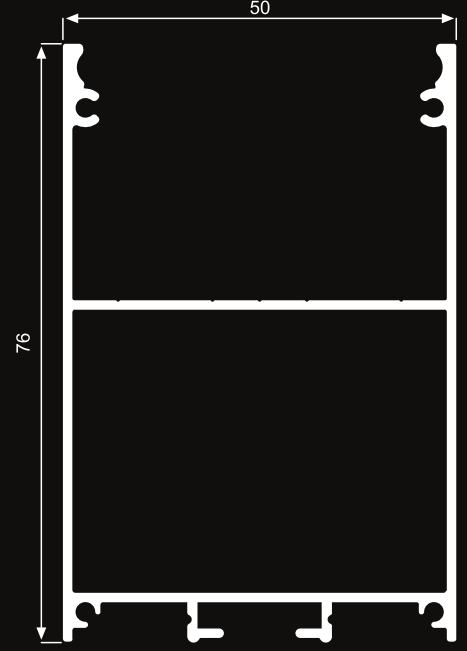

**2306**

|  |       |
|--|-------|
| Çevre (mm)<br><i>Perimeter</i>         | 562,6 |
| Alan (mm <sup>2</sup> )<br><i>Area</i> | 347,7 |
| Ağırlık (gr/m)<br><i>Weight</i>        | 942   |

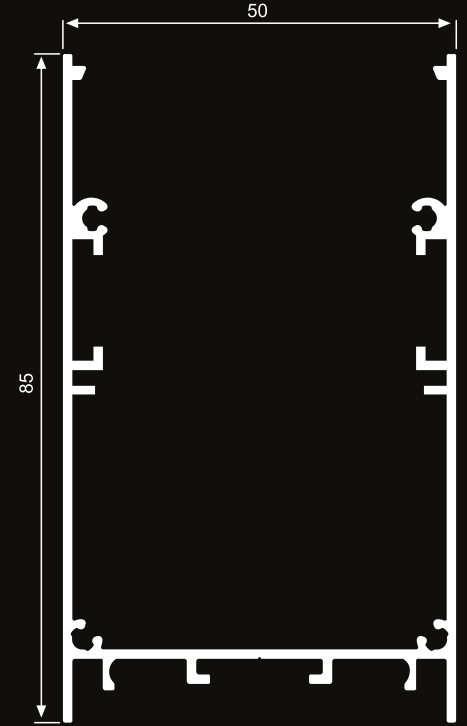

**2307**

|  |       |
|--|-------|
| Çevre (mm)<br><i>Perimeter</i>         | 108,8 |
| Alan (mm <sup>2</sup> )<br><i>Area</i> | 53,7  |
| Ağırlık (gr/m)<br><i>Weight</i>        | 145   |

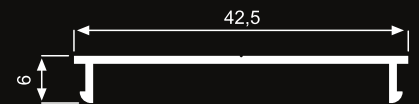





Alaşım Alüminyum

**2319**

|  |       |
|--|-------|
| Çevre (mm)<br><i>Perimeter</i>         | 451,8 |
| Alan (mm <sup>2</sup> )<br><i>Area</i> | 379,7 |
| Ağırlık (gr/m)<br><i>Weight</i>        | 1029  |

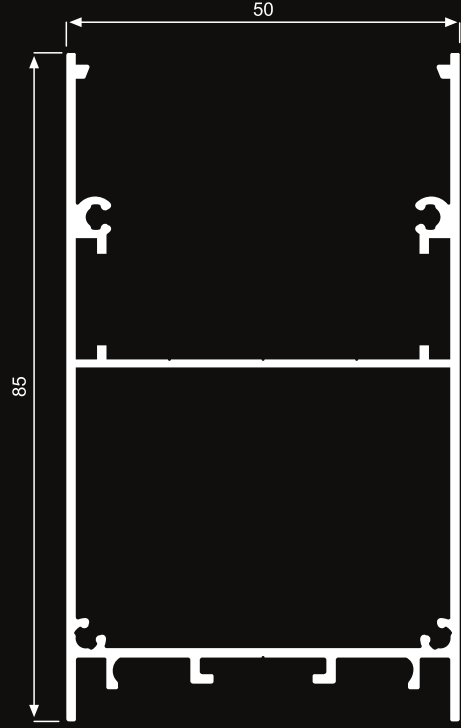

**2449**

\* Özel üründür

|  |       |
|--|-------|
| Çevre (mm)<br><i>Perimeter</i>         | 577,8 |
| Alan (mm <sup>2</sup> )<br><i>Area</i> | 408,8 |
| Ağırlık (gr/m)<br><i>Weight</i>        | 1108  |

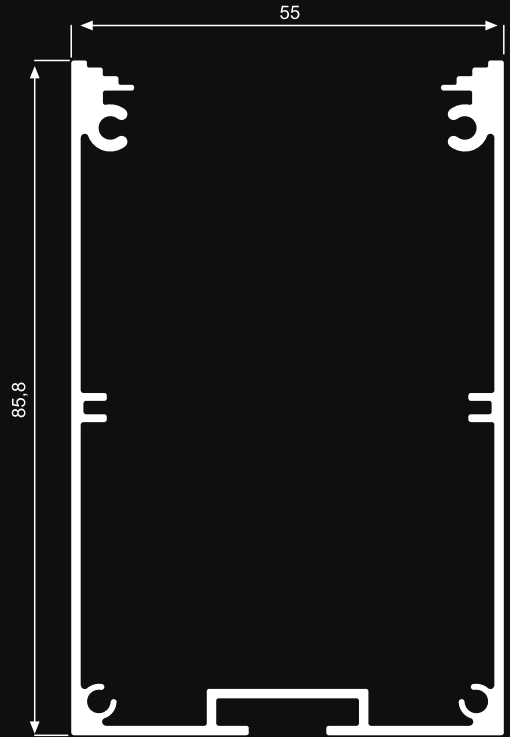



Alaşım Alüminyum

**2450**

|  |     |
|--|-----|
| Çevre (mm)<br><i>Perimeter</i>         | 547 |
| Alan (mm <sup>2</sup> )<br><i>Area</i> | 355 |
| Ağırlık (gr/m)<br><i>Weight</i>        | 963 |

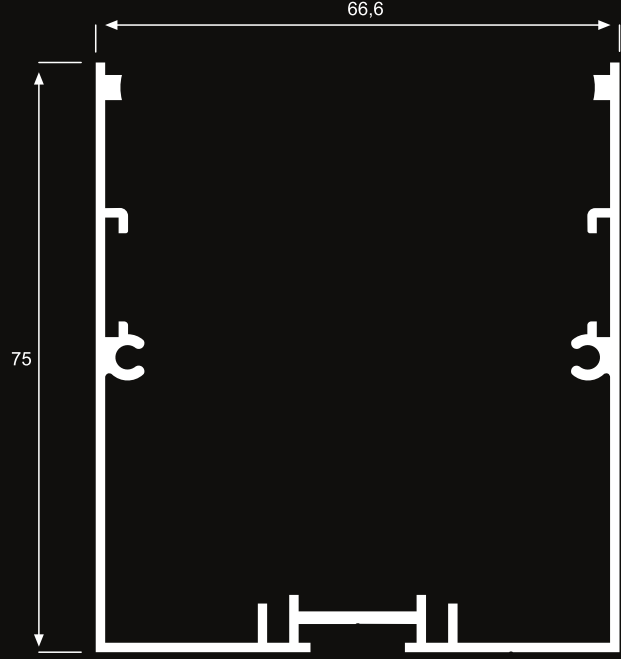

**2455**

|  |       |
|--|-------|
| Çevre (mm)<br><i>Perimeter</i>         | 404,4 |
| Alan (mm <sup>2</sup> )<br><i>Area</i> | 335   |
| Ağırlık (gr/m)<br><i>Weight</i>        | 907   |

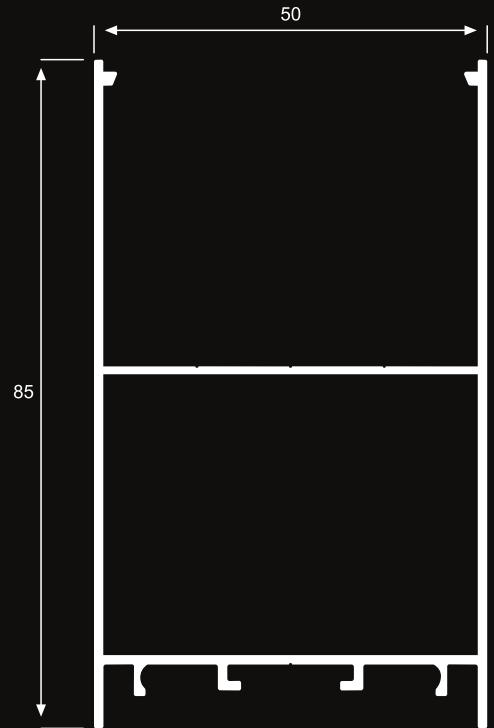



Alaşım Alüminyum

**2500**

|                                 |     |
|---------------------------------|-----|
| Çevre (mm)<br>Perimeter         | 390 |
| Alan (mm <sup>2</sup> )<br>Area | 328 |
| Ağırlık (gr/m)<br>Weight        | 889 |

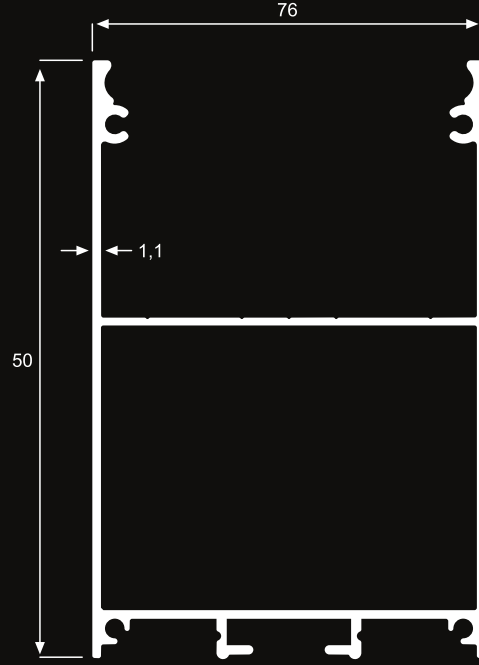

**1860**

|                                 |       |
|---------------------------------|-------|
| Çevre (mm)<br>Perimeter         | 643   |
| Alan (mm <sup>2</sup> )<br>Area | 492.9 |
| Ağırlık (gr/m)<br>Weight        | 1336  |

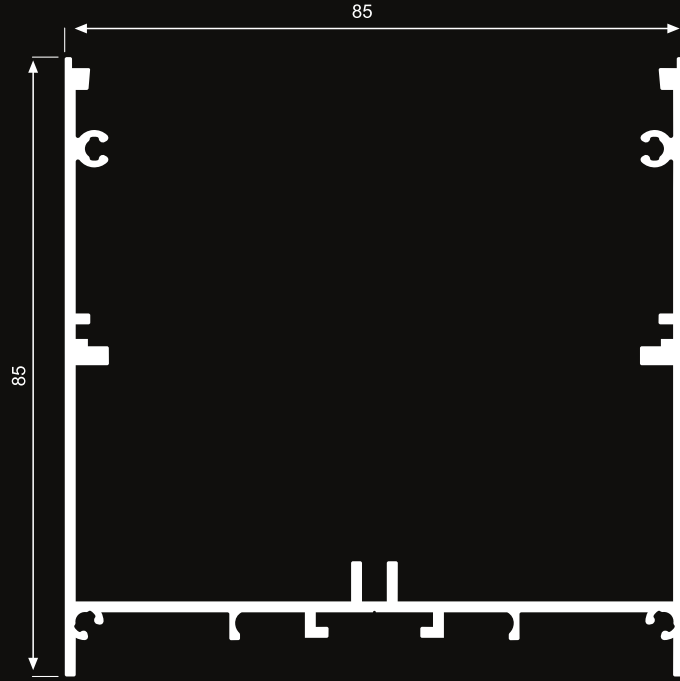

**1859**

|                                 |       |
|---------------------------------|-------|
| Çevre (mm)<br>Perimeter         | 308.5 |
| Alan (mm <sup>2</sup> )<br>Area | 127.4 |
| Ağırlık (gr/m)<br>Weight        | 345   |

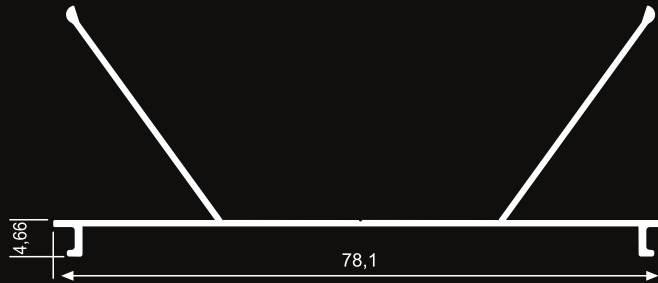



Alaşım Alüminyum

**2320**

|                                 |       |
|---------------------------------|-------|
| Çevre (mm)<br>Perimeter         | 644,1 |
| Alan (mm <sup>2</sup> )<br>Area | 474,1 |
| Ağırlık (gr/m)<br>Weight        | 1285  |

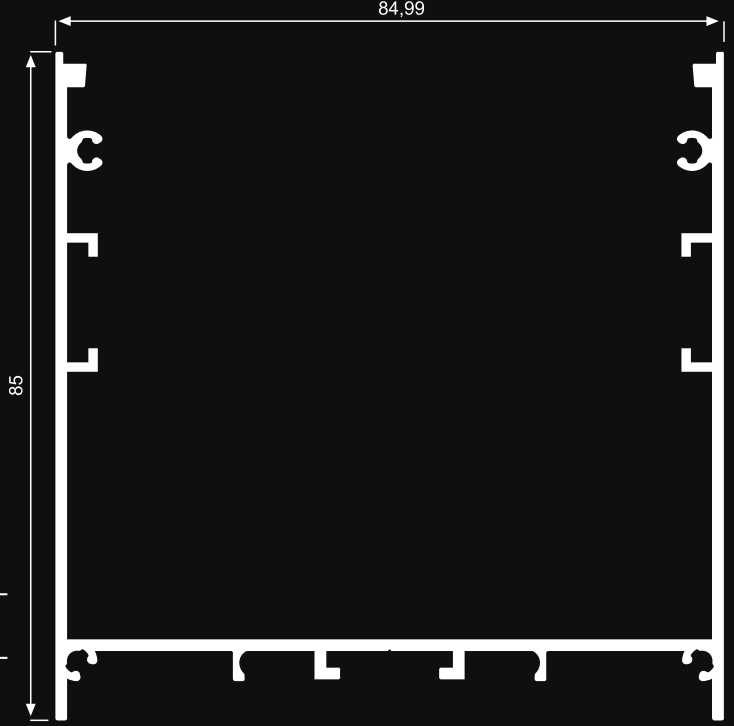

**2317**

|                                 |       |
|---------------------------------|-------|
| Çevre (mm)<br>Perimeter         | 178,4 |
| Alan (mm <sup>2</sup> )<br>Area | 88,2  |
| Ağırlık (gr/m)<br>Weight        | 239   |

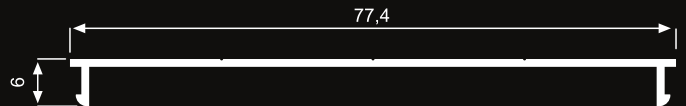



Alaşım Alüminyum

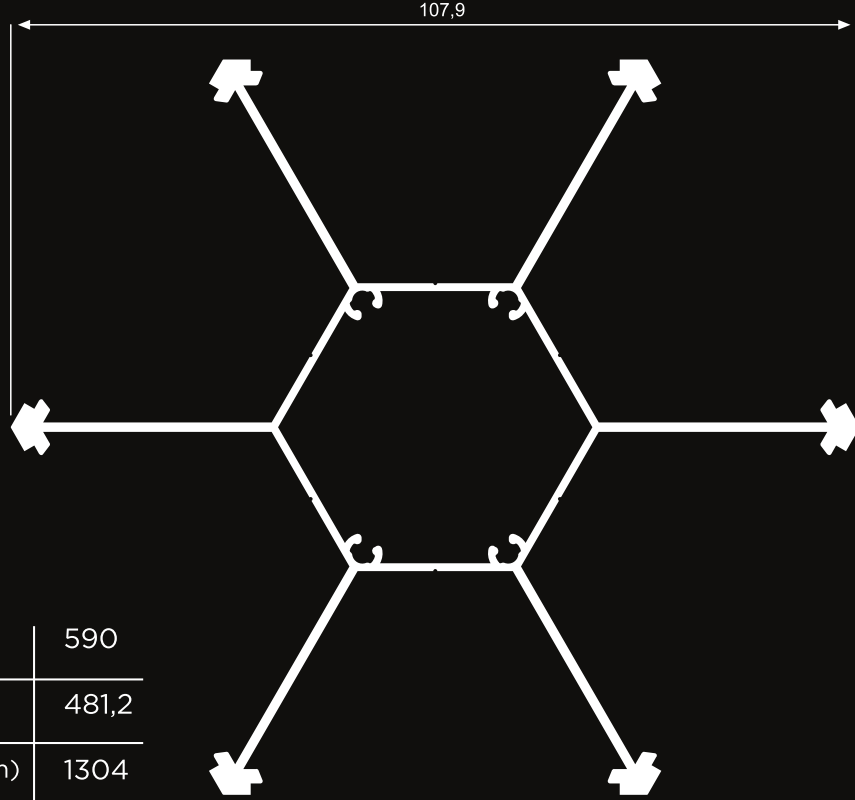

**2373**

|                                 |       |
|---------------------------------|-------|
| Çevre (mm)<br>Perimeter         | 590   |
| Alan (mm <sup>2</sup> )<br>Area | 481,2 |
| Ağırlık (gr/m)<br>Weight        | 1304  |

**2374**

|                                 |      |
|---------------------------------|------|
| Çevre (mm)<br>Perimeter         | 115  |
| Alan (mm <sup>2</sup> )<br>Area | 76,2 |
| Ağırlık (gr/m)<br>Weight        | 206  |





Alaşım Alüminyum

|             |  |       |
|-------------|--|-------|
| <b>2214</b> | Çevre (mm)<br><i>Perimeter</i>         | 421.8 |
|             | Alan (mm <sup>2</sup> )<br><i>Area</i> | 454.3 |
|             | Ağırlık (gr/m)<br><i>Weight</i>        | 1231  |

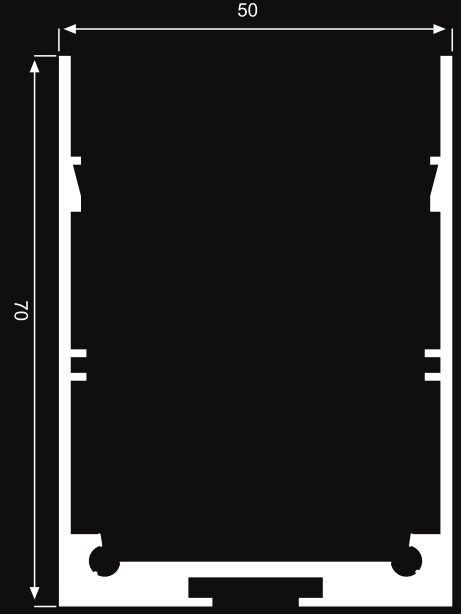

|             |  |       |
|-------------|--|-------|
| <b>2215</b> | Çevre (mm)<br><i>Perimeter</i>         | 137.8 |
|             | Alan (mm <sup>2</sup> )<br><i>Area</i> | 89    |
|             | Ağırlık (gr/m)<br><i>Weight</i>        | 241   |

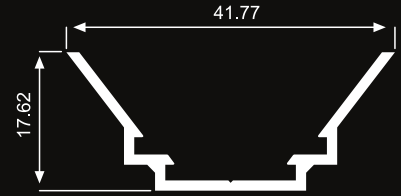

|             |  |       |
|-------------|--|-------|
| <b>2144</b> | Çevre (mm)<br><i>Perimeter</i>         | 179.6 |
|             | Alan (mm <sup>2</sup> )<br><i>Area</i> | 167.3 |
|             | Ağırlık (gr/m)<br><i>Weight</i>        | 453.4 |

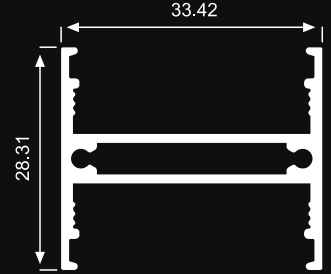

|             |  |       |
|-------------|--|-------|
| <b>2174</b> | Çevre (mm)<br><i>Perimeter</i>         | 140.7 |
|             | Alan (mm <sup>2</sup> )<br><i>Area</i> | 155   |
|             | Ağırlık (gr/m)<br><i>Weight</i>        | 420   |

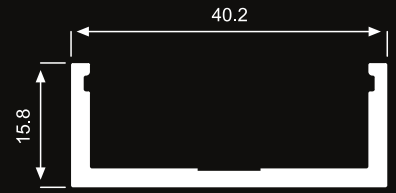

|             |  |       |
|-------------|--|-------|
| <b>2175</b> | Çevre (mm)<br><i>Perimeter</i>         | 197   |
|             | Alan (mm <sup>2</sup> )<br><i>Area</i> | 207.5 |
|             | Ağırlık (gr/m)<br><i>Weight</i>        | 562   |

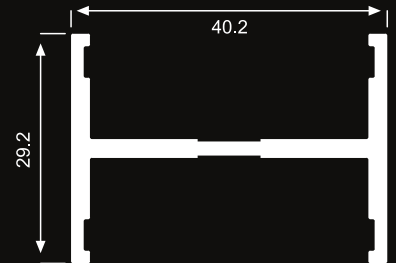



Alaşım Alüminyum

**1862**

Çevre (mm)  
Perimeter

486.1

Alan (mm<sup>2</sup>)  
Area

382

Ağırlık (gr/m)  
Weight

1035

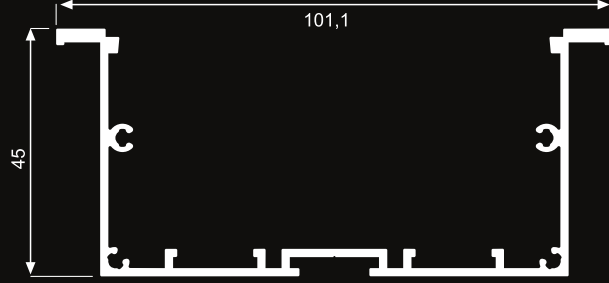

**1866**

Çevre (mm)  
Perimeter

351.1

Alan (mm<sup>2</sup>)  
Area

299.9

Ağırlık (gr/m)  
Weight

813

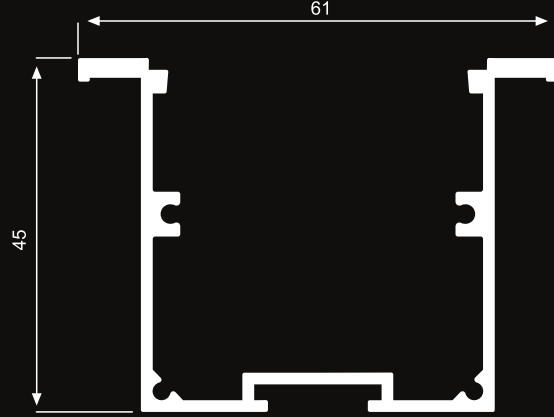

**2201**

Çevre (mm)  
Perimeter

284

Alan (mm<sup>2</sup>)  
Area

208.4

Ağırlık (gr/m)  
Weight

565

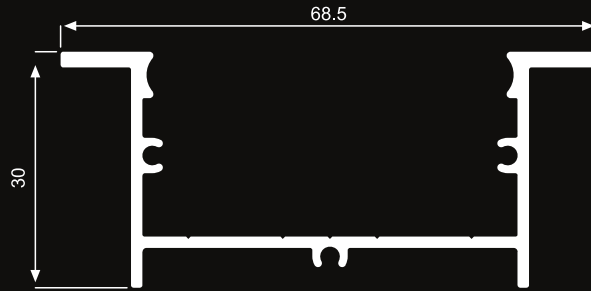

**2139**

Çevre (mm)  
Perimeter

333,7

Alan (mm<sup>2</sup>)  
Area

270,8

Ağırlık (gr/m)  
Weight

733,9

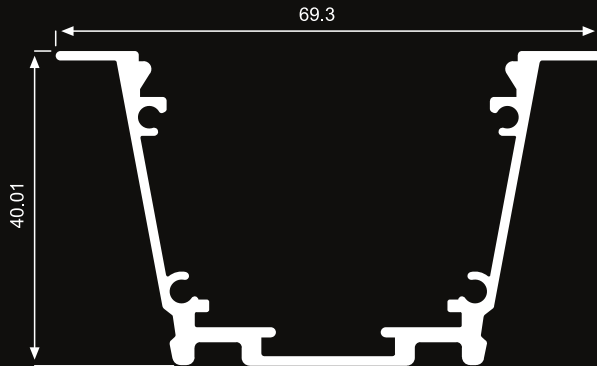



Alaşım Alüminyum

|             |  |       |
|-------------|--|-------|
| <b>2141</b> | Çevre (mm)<br><i>Perimeter</i>         | 320.2 |
|             | Alan (mm <sup>2</sup> )<br><i>Area</i> | 213   |
|             | Ağırlık (gr/m)<br><i>Weight</i>        | 577.2 |

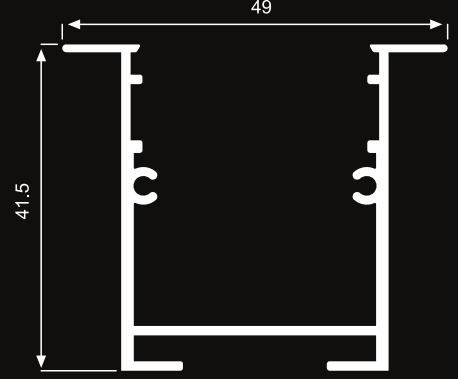

|             |  |       |
|-------------|--|-------|
| <b>2142</b> | Çevre (mm)<br><i>Perimeter</i>         | 310.2 |
|             | Alan (mm <sup>2</sup> )<br><i>Area</i> | 227.8 |
|             | Ağırlık (gr/m)<br><i>Weight</i>        | 617.3 |

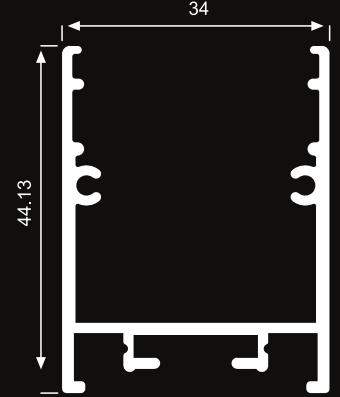

|             |  |       |
|-------------|--|-------|
| <b>2143</b> | Çevre (mm)<br><i>Perimeter</i>         | 257.6 |
|             | Alan (mm <sup>2</sup> )<br><i>Area</i> | 180   |
|             | Ağırlık (gr/m)<br><i>Weight</i>        | 487.8 |

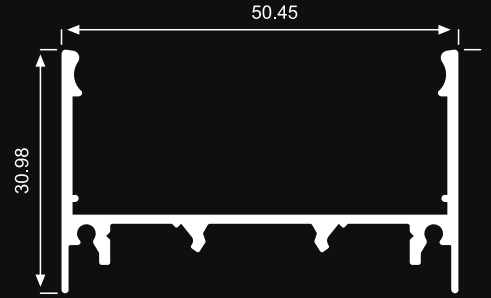

|             |  |       |
|-------------|--|-------|
| <b>2505</b> | Çevre (mm)<br><i>Perimeter</i>         | 342,1 |
|             | Alan (mm <sup>2</sup> )<br><i>Area</i> | 188,3 |
|             | Ağırlık (gr/m)<br><i>Weight</i>        | 510   |







Alaşım Alüminyum

**2184**

Çevre (mm)  
Perimeter

308.8

\* Özel üründür

Alan (mm<sup>2</sup>)  
Area

176.8

Ağırlık (gr/m)  
Weight

479

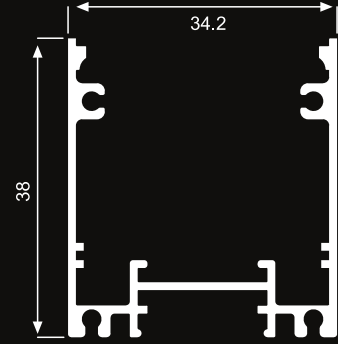

**2185**

Çevre (mm)  
Perimeter

395

\* Özel üründür

Alan (mm<sup>2</sup>)  
Area

235.6

Ağırlık (gr/m)  
Weight

638

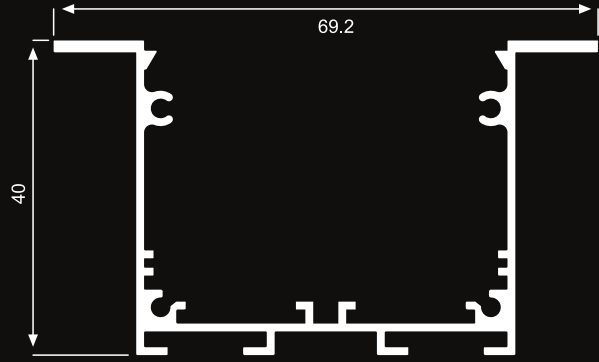

**2186**

Çevre (mm)  
Perimeter

340

\* Özel üründür

Alan (mm<sup>2</sup>)  
Area

204.2

Ağırlık (gr/m)  
Weight

553

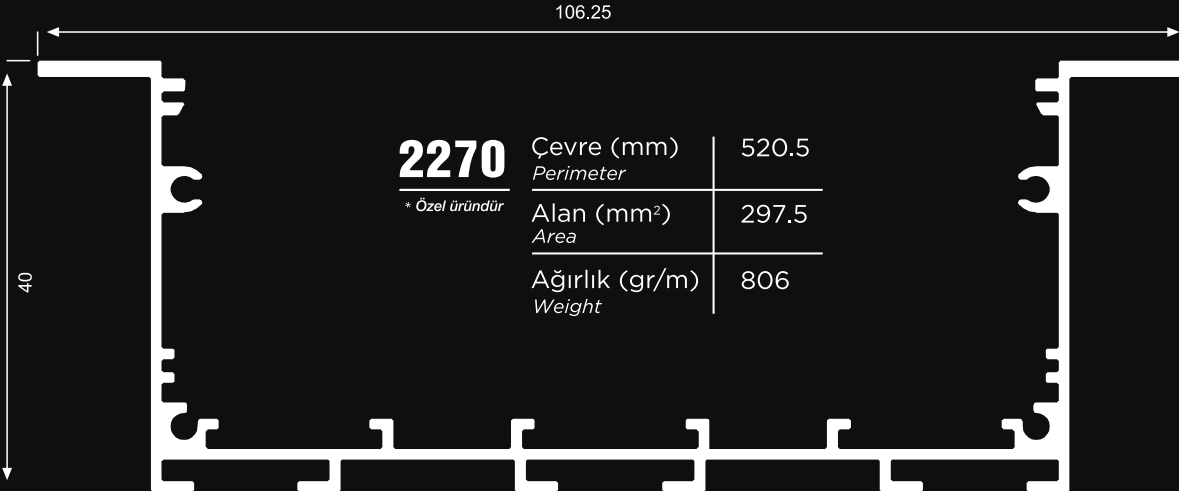
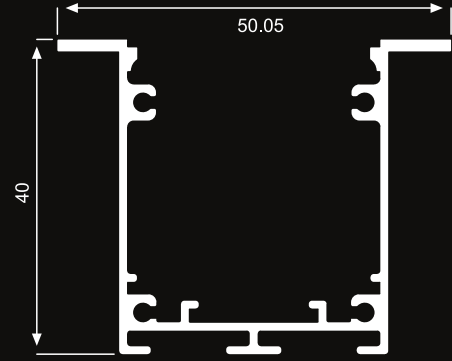

**2270**

\* Özel üründür

Çevre (mm)  
Perimeter

520.5

Alan (mm<sup>2</sup>)  
Area

297.5

Ağırlık (gr/m)  
Weight

806



Alaşım Alüminyum

|             |                                 |       |
|-------------|---------------------------------|-------|
| <b>2316</b> | Çevre (mm)<br>Perimeter         | 383,2 |
|             | Alan (mm <sup>2</sup> )<br>Area | 232,3 |
|             | Ağırlık (gr/m)<br>Weight        | 629   |

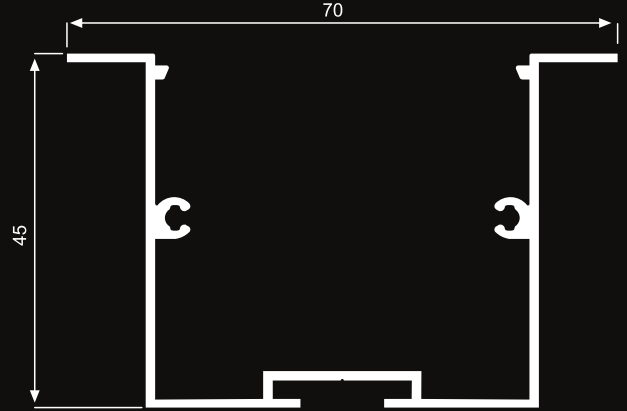

|             |                                 |       |
|-------------|---------------------------------|-------|
| <b>2318</b> | Çevre (mm)<br>Perimeter         | 394,5 |
|             | Alan (mm <sup>2</sup> )<br>Area | 241,1 |
|             | Ağırlık (gr/m)<br>Weight        | 653   |

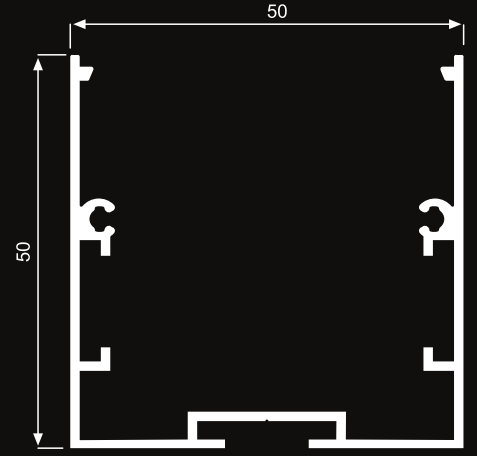

|             |                                 |       |
|-------------|---------------------------------|-------|
| <b>2308</b> | Çevre (mm)<br>Perimeter         | 265,3 |
|             | Alan (mm <sup>2</sup> )<br>Area | 159,6 |
|             | Ağırlık (gr/m)<br>Weight        | 432   |

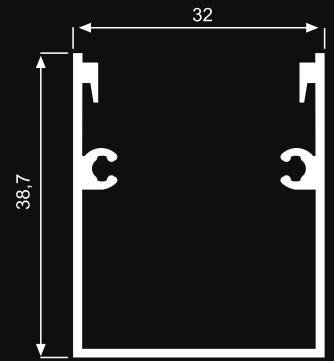

|             |                                 |       |
|-------------|---------------------------------|-------|
| <b>2309</b> | Çevre (mm)<br>Perimeter         | 322   |
|             | Alan (mm <sup>2</sup> )<br>Area | 187,8 |
|             | Ağırlık (gr/m)<br>Weight        | 509   |

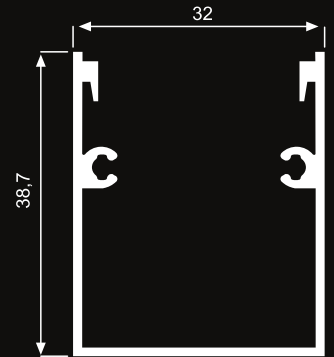



Alaşım Alüminyum

**2499**

|                                 |       |
|---------------------------------|-------|
| Çevre (mm)<br>Perimeter         | 281,5 |
| Alan (mm <sup>2</sup> )<br>Area | 285,9 |
| Ağırlık (gr/m)<br>Weight        | 774   |

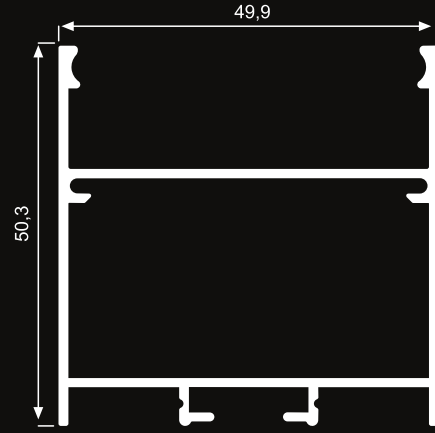

**2504**

|                                 |       |
|---------------------------------|-------|
| Çevre (mm)<br>Perimeter         | 280,1 |
| Alan (mm <sup>2</sup> )<br>Area | 158,9 |
| Ağırlık (gr/m)<br>Weight        | 431   |

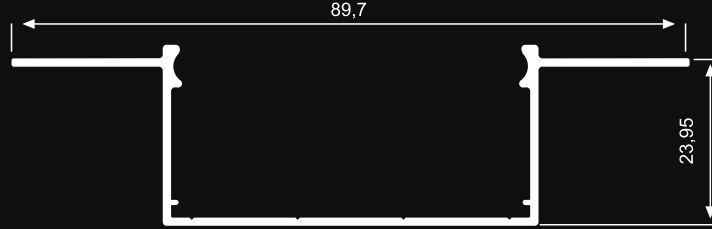

**2187**

\* Özel üründür

|                                 |       |
|---------------------------------|-------|
| Çevre (mm)<br>Perimeter         | 180,9 |
| Alan (mm <sup>2</sup> )<br>Area | 91,4  |
| Ağırlık (gr/m)<br>Weight        | 248   |



**2188**

\* Özel üründür

|                                 |       |
|---------------------------------|-------|
| Çevre (mm)<br>Perimeter         | 254,4 |
| Alan (mm <sup>2</sup> )<br>Area | 299,7 |
| Ağırlık (gr/m)<br>Weight        | 812   |

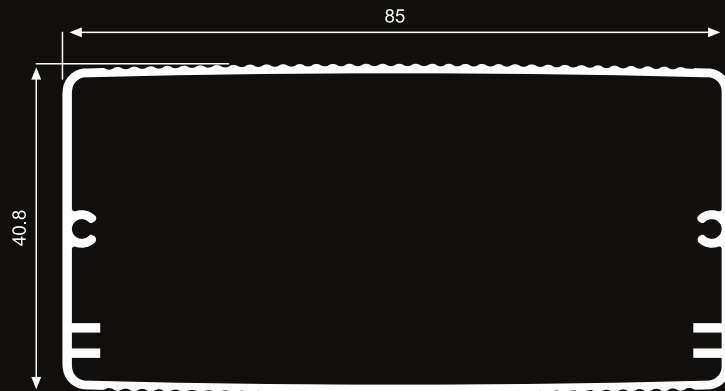



## Alaşım Alüminyum

|             |                                 |       |
|-------------|---------------------------------|-------|
| <b>2334</b> | Çevre (mm)<br>Perimeter         | 129,6 |
|             | Alan (mm <sup>2</sup> )<br>Area | 76,3  |
|             | Ağırlık (gr/m)<br>Weight        | 206   |

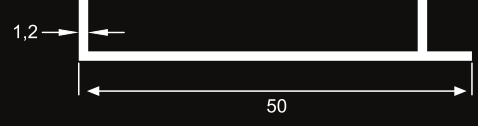

|             |                                 |       |
|-------------|---------------------------------|-------|
| <b>2250</b> | Çevre (mm)<br>Perimeter         | 127.6 |
|             | Alan (mm <sup>2</sup> )<br>Area | 96.1  |
|             | Ağırlık (gr/m)<br>Weight        | 260   |

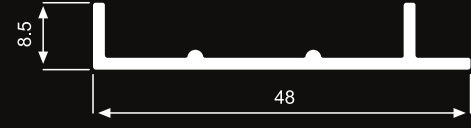

|             |                                 |       |
|-------------|---------------------------------|-------|
| <b>1864</b> | Çevre (mm)<br>Perimeter         | 180.6 |
|             | Alan (mm <sup>2</sup> )<br>Area | 172.6 |
|             | Ağırlık (gr/m)<br>Weight        | 468   |

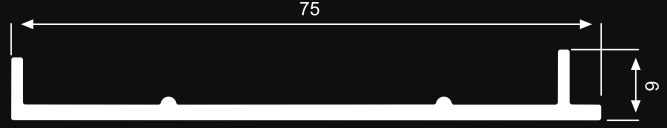

|             |                                 |       |
|-------------|---------------------------------|-------|
| <b>1865</b> | Çevre (mm)<br>Perimeter         | 194.4 |
|             | Alan (mm <sup>2</sup> )<br>Area | 183.1 |
|             | Ağırlık (gr/m)<br>Weight        | 496   |

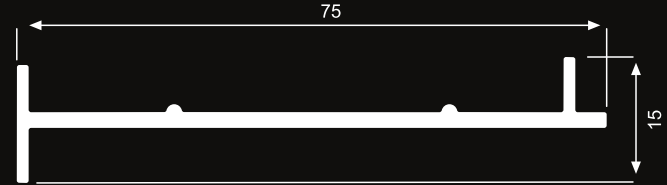

|             |                                 |       |
|-------------|---------------------------------|-------|
| <b>2338</b> | Çevre (mm)<br>Perimeter         | 180,3 |
|             | Alan (mm <sup>2</sup> )<br>Area | 133,5 |
|             | Ağırlık (gr/m)<br>Weight        | 362   |

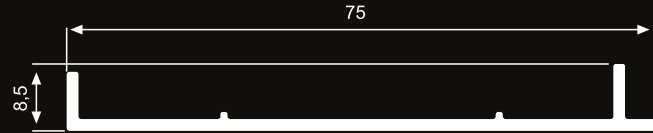

|             |                                 |       |
|-------------|---------------------------------|-------|
| <b>2249</b> | Çevre (mm)<br>Perimeter         | 187.6 |
|             | Alan (mm <sup>2</sup> )<br>Area | 141.1 |
|             | Ağırlık (gr/m)<br>Weight        | 382   |

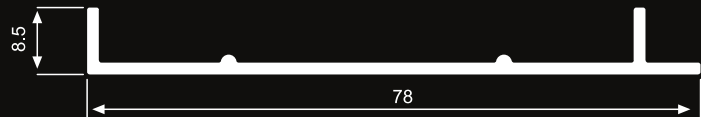



Alaşım Alüminyum

|             |                                 |     |
|-------------|---------------------------------|-----|
| <b>2054</b> | Çevre (mm)<br>Perimeter         | 238 |
|             | Alan (mm <sup>2</sup> )<br>Area | 165 |
|             | Ağırlık (gr/m)<br>Weight        | 448 |

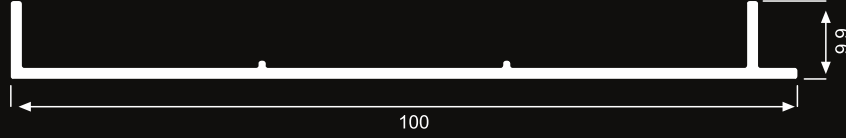

|             |                                 |       |
|-------------|---------------------------------|-------|
| <b>2053</b> | Çevre (mm)<br>Perimeter         | 106.7 |
|             | Alan (mm <sup>2</sup> )<br>Area | 57    |
|             | Ağırlık (gr/m)<br>Weight        | 155   |

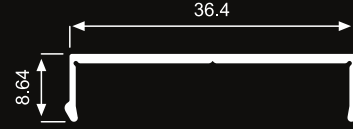

|             |                                 |      |
|-------------|---------------------------------|------|
| <b>2138</b> | Çevre (mm)<br>Perimeter         | 69.9 |
|             | Alan (mm <sup>2</sup> )<br>Area | 34.7 |
|             | Ağırlık (gr/m)<br>Weight        | 94   |



|             |                                 |      |
|-------------|---------------------------------|------|
| <b>2183</b> | Çevre (mm)<br>Perimeter         | 51.3 |
|             | Alan (mm <sup>2</sup> )<br>Area | 24.6 |
|             | Ağırlık (gr/m)<br>Weight        | 67   |

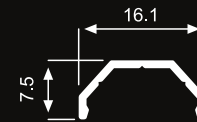

|             |                                 |      |
|-------------|---------------------------------|------|
| <b>2195</b> | Çevre (mm)<br>Perimeter         | 110  |
|             | Alan (mm <sup>2</sup> )<br>Area | 98.6 |
|             | Ağırlık (gr/m)<br>Weight        | 267  |

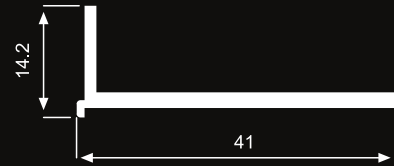

|             |                                 |       |
|-------------|---------------------------------|-------|
| <b>2265</b> | Çevre (mm)<br>Perimeter         | 153.4 |
|             | Alan (mm <sup>2</sup> )<br>Area | 186.6 |
|             | Ağırlık (gr/m)<br>Weight        | 506   |

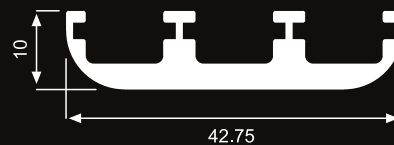



Alaşım Alüminyum

|             |                                 |     |
|-------------|---------------------------------|-----|
| <b>2056</b> | Çevre (mm)<br>Perimeter         | 198 |
|             | Alan (mm <sup>2</sup> )<br>Area | 346 |
|             | Ağırlık (gr/m)<br>Weight        | 938 |

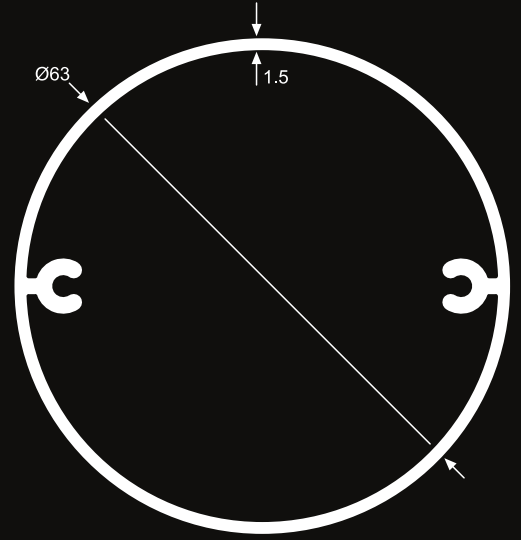

|             |                                 |      |
|-------------|---------------------------------|------|
| <b>2102</b> | Çevre (mm)<br>Perimeter         | 555  |
|             | Alan (mm <sup>2</sup> )<br>Area | 646  |
|             | Ağırlık (gr/m)<br>Weight        | 1751 |

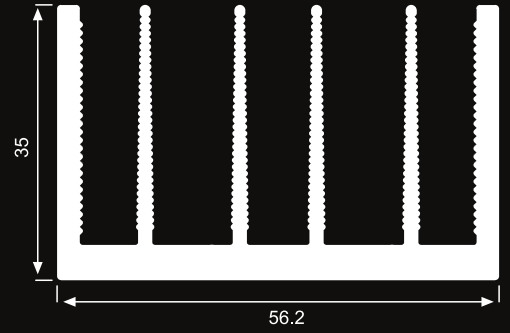

|             |                                 |        |
|-------------|---------------------------------|--------|
| <b>2134</b> | Çevre (mm)<br>Perimeter         | 415    |
|             | Alan (mm <sup>2</sup> )<br>Area | 399.9  |
|             | Ağırlık (gr/m)<br>Weight        | 1083.7 |

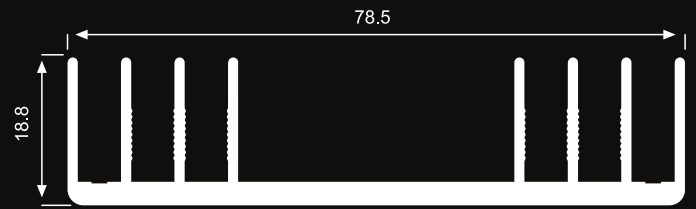

|             |                                 |        |
|-------------|---------------------------------|--------|
| <b>2135</b> | Çevre (mm)<br>Perimeter         | 682.9  |
|             | Alan (mm <sup>2</sup> )<br>Area | 1200.9 |
|             | Ağırlık (gr/m)<br>Weight        | 3254.4 |

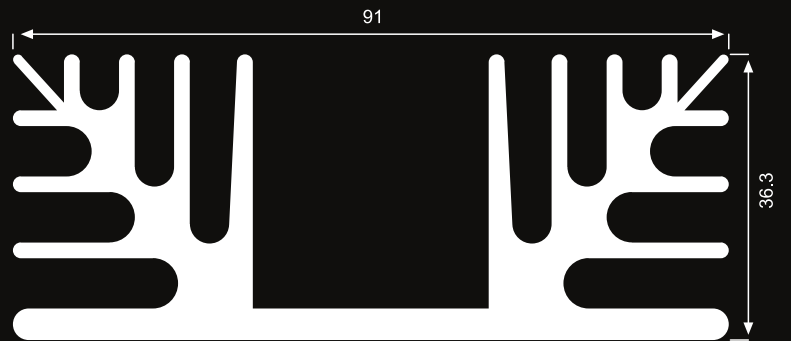



Alaşım Alüminyum

**2136**

|                                 |        |
|---------------------------------|--------|
| Çevre (mm)<br>Perimeter         | 611.4  |
| Alan (mm <sup>2</sup> )<br>Area | 1122.2 |
| Ağırlık (gr/m)<br>Weight        | 3041.2 |

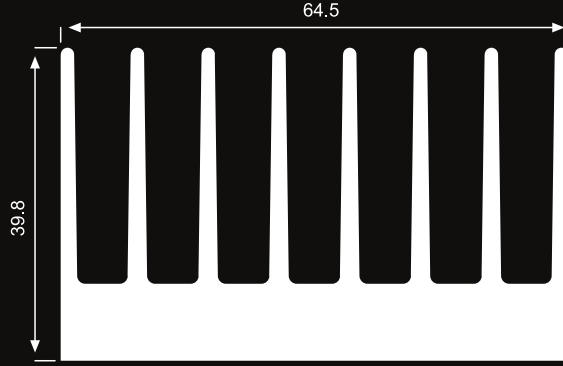

**2137**

|                                 |        |
|---------------------------------|--------|
| Çevre (mm)<br>Perimeter         | 311.6  |
| Alan (mm <sup>2</sup> )<br>Area | 527.2  |
| Ağırlık (gr/m)<br>Weight        | 1428.7 |

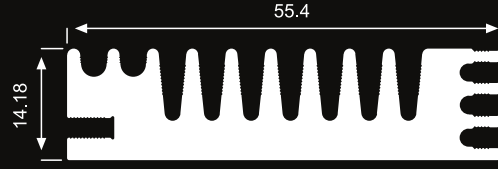

**2154**

|                                 |       |
|---------------------------------|-------|
| Çevre (mm)<br>Perimeter         | 371.8 |
| Alan (mm <sup>2</sup> )<br>Area | 600.7 |
| Ağırlık (gr/m)<br>Weight        | 1628  |

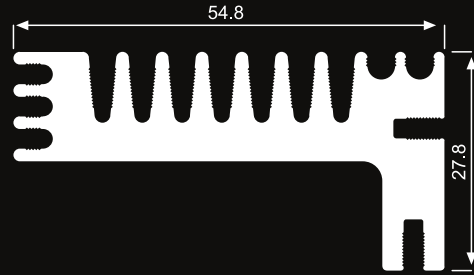

**2156**

|                                 |       |
|---------------------------------|-------|
| Çevre (mm)<br>Perimeter         | 205.1 |
| Alan (mm <sup>2</sup> )<br>Area | 137.6 |
| Ağırlık (gr/m)<br>Weight        | 372.9 |





Alaşım Alüminyum

|             |  |      |
|-------------|--|------|
| <b>1899</b> | Çevre (mm)<br><i>Perimeter</i>         | 72.8 |
|             | Alan (mm <sup>2</sup> )<br><i>Area</i> | 63   |
|             | Ağırlık (gr/m)<br><i>Weight</i>        | 170  |

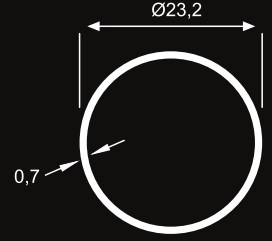

|             |  |      |
|-------------|--|------|
| <b>1900</b> | Çevre (mm)<br><i>Perimeter</i>         | 81.7 |
|             | Alan (mm <sup>2</sup> )<br><i>Area</i> | 48.1 |
|             | Ağırlık (gr/m)<br><i>Weight</i>        | 130  |

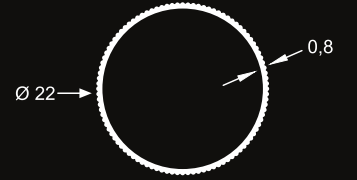

|             |  |      |
|-------------|--|------|
| <b>1901</b> | Çevre (mm)<br><i>Perimeter</i>         | 69.1 |
|             | Alan (mm <sup>2</sup> )<br><i>Area</i> | 53.2 |
|             | Ağırlık (gr/m)<br><i>Weight</i>        | 144  |

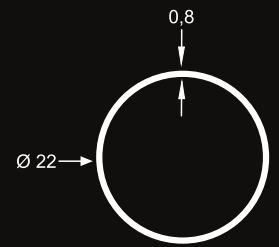

|             |  |       |
|-------------|--|-------|
| <b>1902</b> | Çevre (mm)<br><i>Perimeter</i>         | 75.4  |
|             | Alan (mm <sup>2</sup> )<br><i>Area</i> | 138.2 |
|             | Ağırlık (gr/m)<br><i>Weight</i>        | 374   |

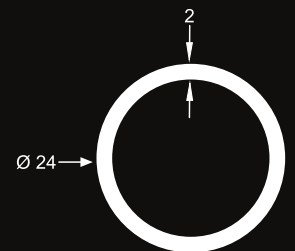





### 1903

|                                 |      |
|---------------------------------|------|
| Çevre (mm)<br>Perimeter         | 69.1 |
| Alan (mm <sup>2</sup> )<br>Area | 59.6 |
| Ağırlık (gr/m)<br>Weight        | 162  |

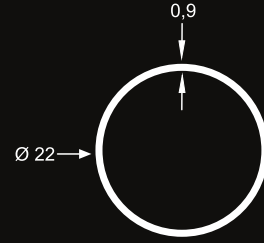

### 1904

|                                 |      |
|---------------------------------|------|
| Çevre (mm)<br>Perimeter         | 83   |
| Alan (mm <sup>2</sup> )<br>Area | 61.1 |
| Ağırlık (gr/m)<br>Weight        | 166  |

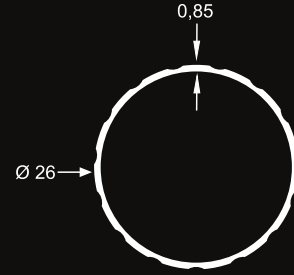

### 1905

|                                 |      |
|---------------------------------|------|
| Çevre (mm)<br>Perimeter         | 78.5 |
| Alan (mm <sup>2</sup> )<br>Area | 60.8 |
| Ağırlık (gr/m)<br>Weight        | 165  |

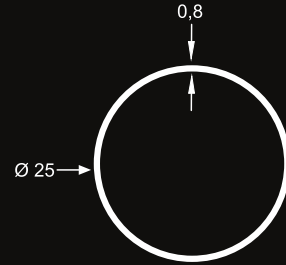

### 1909

|                                 |      |
|---------------------------------|------|
| Çevre (mm)<br>Perimeter         | 69.1 |
| Alan (mm <sup>2</sup> )<br>Area | 53.2 |
| Ağırlık (gr/m)<br>Weight        | 144  |

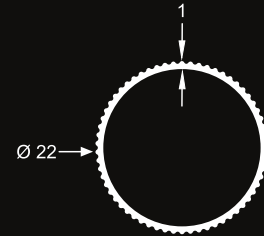

### 1911

|                                 |      |
|---------------------------------|------|
| Çevre (mm)<br>Perimeter         | 81.6 |
| Alan (mm <sup>2</sup> )<br>Area | 70.9 |
| Ağırlık (gr/m)<br>Weight        | 192  |

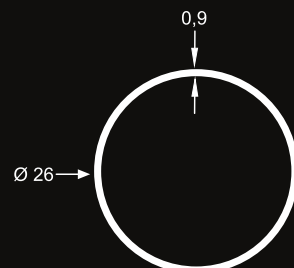



Alaşım Alüminyum

|             |                                 |      |
|-------------|---------------------------------|------|
| <b>2075</b> | Çevre (mm)<br>Perimeter         | 67.7 |
|             | Alan (mm <sup>2</sup> )<br>Area | 51.4 |
|             | Ağırlık (gr/m)<br>Weight        | 134  |

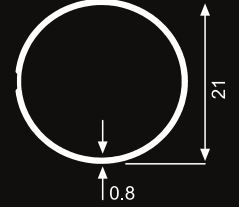

|             |                                 |      |
|-------------|---------------------------------|------|
| <b>2086</b> | Çevre (mm)<br>Perimeter         | 76.2 |
|             | Alan (mm <sup>2</sup> )<br>Area | 70.5 |
|             | Ağırlık (gr/m)<br>Weight        | 191  |

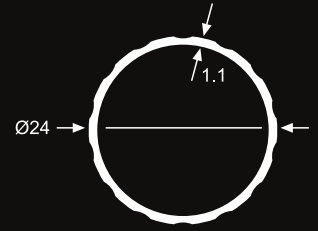

|             |                                 |      |
|-------------|---------------------------------|------|
| <b>2106</b> | Çevre (mm)<br>Perimeter         | 66.9 |
|             | Alan (mm <sup>2</sup> )<br>Area | 57.6 |
|             | Ağırlık (gr/m)<br>Weight        | 156  |

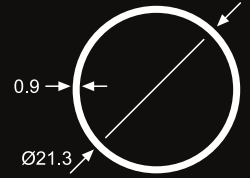

|             |                                 |       |
|-------------|---------------------------------|-------|
| <b>2161</b> | Çevre (mm)<br>Perimeter         | 67.9  |
|             | Alan (mm <sup>2</sup> )<br>Area | 58.5  |
|             | Ağırlık (gr/m)<br>Weight        | 158.5 |

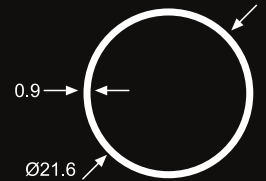

|             |                                 |      |
|-------------|---------------------------------|------|
| <b>2171</b> | Çevre (mm)<br>Perimeter         | 76.7 |
|             | Alan (mm <sup>2</sup> )<br>Area | 56.5 |
|             | Ağırlık (gr/m)<br>Weight        | 153  |

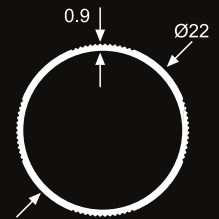

|             |                                 |       |
|-------------|---------------------------------|-------|
| <b>2172</b> | Çevre (mm)<br>Perimeter         | 101.8 |
|             | Alan (mm <sup>2</sup> )<br>Area | 93.5  |
|             | Ağırlık (gr/m)<br>Weight        | 253   |

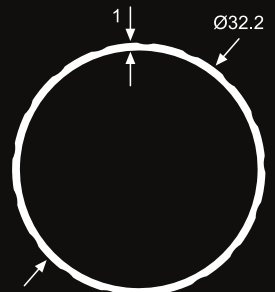



|             |                                 |      |
|-------------|---------------------------------|------|
| <b>2178</b> | Çevre (mm)<br>Perimeter         | 71.6 |
|             | Alan (mm <sup>2</sup> )<br>Area | 55.3 |
|             | Ağırlık (gr/m)<br>Weight        | 150  |

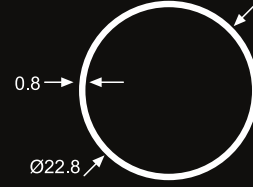

|             |                                 |      |
|-------------|---------------------------------|------|
| <b>2179</b> | Çevre (mm)<br>Perimeter         | 57.5 |
|             | Alan (mm <sup>2</sup> )<br>Area | 49.2 |
|             | Ağırlık (gr/m)<br>Weight        | 133  |

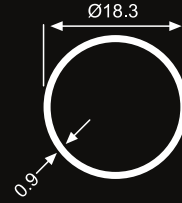

|             |                                 |      |
|-------------|---------------------------------|------|
| <b>2180</b> | Çevre (mm)<br>Perimeter         | 63.7 |
|             | Alan (mm <sup>2</sup> )<br>Area | 54.8 |
|             | Ağırlık (gr/m)<br>Weight        | 149  |

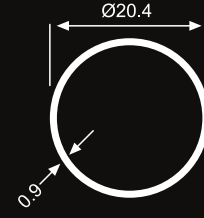

|             |                                 |       |
|-------------|---------------------------------|-------|
| <b>2168</b> | Çevre (mm)<br>Perimeter         | 78.5  |
|             | Alan (mm <sup>2</sup> )<br>Area | 110.7 |
|             | Ağırlık (gr/m)<br>Weight        | 300   |

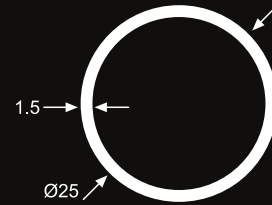

|             |                                 |     |
|-------------|---------------------------------|-----|
| <b>2085</b> | Çevre (mm)<br>Perimeter         | 120 |
|             | Alan (mm <sup>2</sup> )<br>Area | 122 |
|             | Ağırlık (gr/m)<br>Weight        | 331 |





Alaşım Alüminyum

|             |  |      |
|-------------|--|------|
| <b>2281</b> | Çevre (mm)<br><i>Perimeter</i>         | 82,1 |
|             | Alan (mm <sup>2</sup> )<br><i>Area</i> | 68,8 |
|             | Ağırlık (gr/m)<br><i>Weight</i>        | 186  |

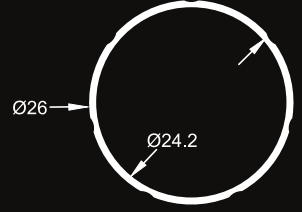

|             |  |      |
|-------------|--|------|
| <b>2282</b> | Çevre (mm)<br><i>Perimeter</i>         | 69,5 |
|             | Alan (mm <sup>2</sup> )<br><i>Area</i> | 57,5 |
|             | Ağırlık (gr/m)<br><i>Weight</i>        | 156  |

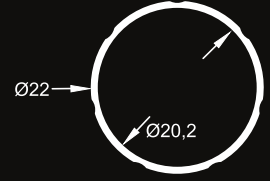

|             |  |      |
|-------------|--|------|
| <b>2283</b> | Çevre (mm)<br><i>Perimeter</i>         | 58,8 |
|             | Alan (mm <sup>2</sup> )<br><i>Area</i> | 47,9 |
|             | Ağırlık (gr/m)<br><i>Weight</i>        | 130  |

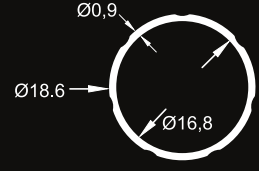

|             |  |     |
|-------------|--|-----|
| <b>2407</b> | Çevre (mm)<br><i>Perimeter</i>         | -   |
|             | Alan (mm <sup>2</sup> )<br><i>Area</i> | -   |
|             | Ağırlık (gr/m)<br><i>Weight</i>        | 128 |

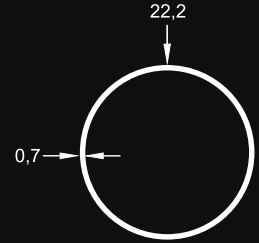

|             |  |      |
|-------------|--|------|
| <b>2297</b> | Çevre (mm)<br><i>Perimeter</i>         | 59,6 |
|             | Alan (mm <sup>2</sup> )<br><i>Area</i> | 24,9 |
|             | Ağırlık (gr/m)<br><i>Weight</i>        | 67   |

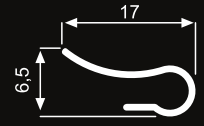

|             |  |       |
|-------------|--|-------|
| <b>2377</b> | Çevre (mm)<br><i>Perimeter</i>         | 199,4 |
|             | Alan (mm <sup>2</sup> )<br><i>Area</i> | 163,4 |
|             | Ağırlık (gr/m)<br><i>Weight</i>        | 442   |

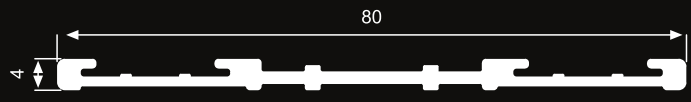



Alaşım Alüminyum

**1794**

|                                 |     |
|---------------------------------|-----|
| Çevre (mm)<br>Perimeter         | 103 |
| Alan (mm <sup>2</sup> )<br>Area | 206 |
| Ağırlık (gr/m)<br>Weight        | 558 |

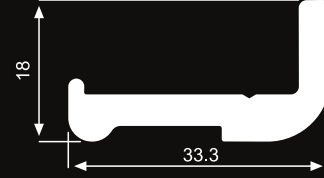

**1795**

|                                 |     |
|---------------------------------|-----|
| Çevre (mm)<br>Perimeter         | 113 |
| Alan (mm <sup>2</sup> )<br>Area | 236 |
| Ağırlık (gr/m)<br>Weight        | 639 |



**1796**

|                                 |      |
|---------------------------------|------|
| Çevre (mm)<br>Perimeter         | 319  |
| Alan (mm <sup>2</sup> )<br>Area | 752  |
| Ağırlık (gr/m)<br>Weight        | 2038 |

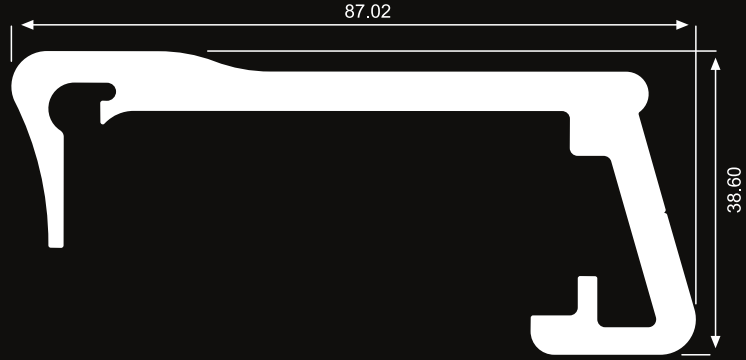

**1797**

|                                 |      |
|---------------------------------|------|
| Çevre (mm)<br>Perimeter         | 369  |
| Alan (mm <sup>2</sup> )<br>Area | 885  |
| Ağırlık (gr/m)<br>Weight        | 2399 |

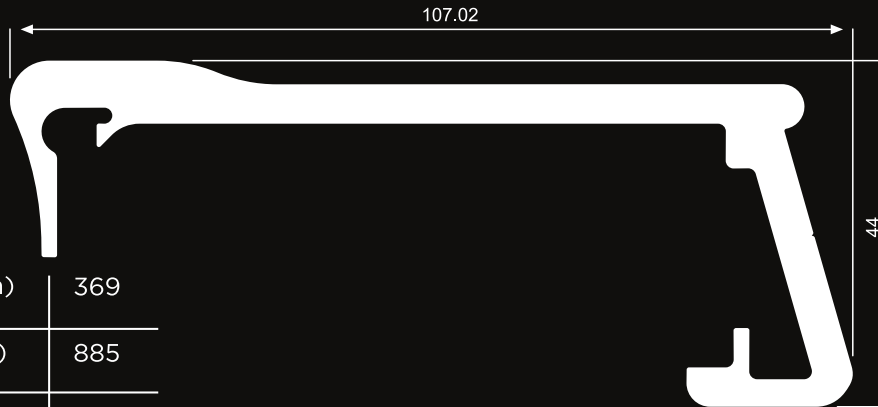

KURUTMALIK PROFİLLERİ  
DRYING PROFILES



Alaşım Alüminyum

|             |                                 |       |
|-------------|---------------------------------|-------|
| <b>1798</b> | Çevre (mm)<br>Perimeter         | 116.6 |
|             | Alan (mm <sup>2</sup> )<br>Area | 126.7 |
|             | Ağırlık (gr/m)<br>Weight        | 343   |

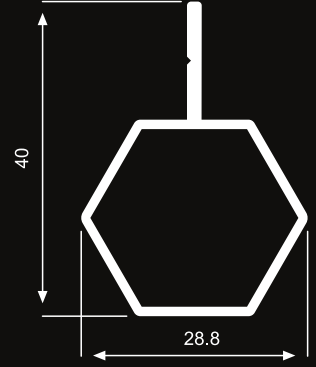

|             |                                 |       |
|-------------|---------------------------------|-------|
| <b>1820</b> | Çevre (mm)<br>Perimeter         | 370.7 |
|             | Alan (mm <sup>2</sup> )<br>Area | 754.1 |
|             | Ağırlık (gr/m)<br>Weight        | 2044  |

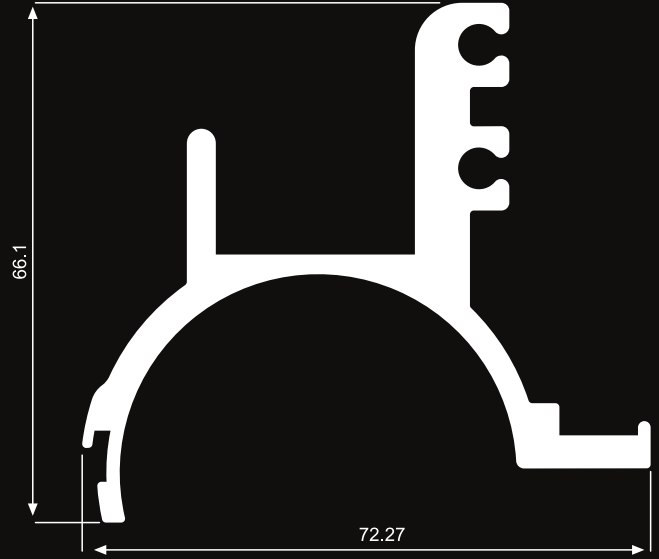

|             |                                 |       |
|-------------|---------------------------------|-------|
| <b>1821</b> | Çevre (mm)<br>Perimeter         | 132.5 |
|             | Alan (mm <sup>2</sup> )<br>Area | 112.7 |
|             | Ağırlık (gr/m)<br>Weight        | 305   |

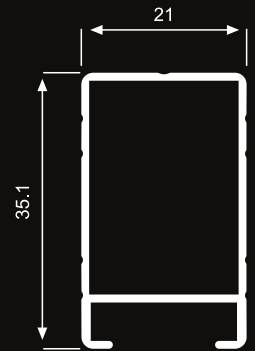

|             |                                 |      |
|-------------|---------------------------------|------|
| <b>1822</b> | Çevre (mm)<br>Perimeter         | 56.5 |
|             | Alan (mm <sup>2</sup> )<br>Area | 53.4 |
|             | Ağırlık (gr/m)<br>Weight        | 144  |

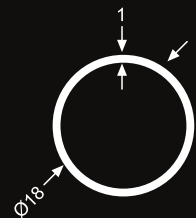



Alaşım Alüminyum

**1823**

|                                 |       |
|---------------------------------|-------|
| Çevre (mm)<br>Perimeter         | 104.4 |
| Alan (mm <sup>2</sup> )<br>Area | 66    |
| Ağırlık (gr/m)<br>Weight        | 178   |

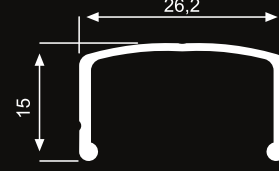

**1838**

|                                 |       |
|---------------------------------|-------|
| Çevre (mm)<br>Perimeter         | 227.6 |
| Alan (mm <sup>2</sup> )<br>Area | 388.3 |
| Ağırlık (gr/m)<br>Weight        | 1052  |

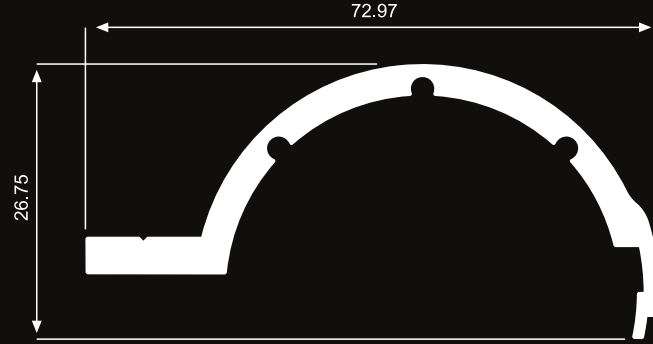

**1855**

|                                 |       |
|---------------------------------|-------|
| Çevre (mm)<br>Perimeter         | 159.1 |
| Alan (mm <sup>2</sup> )<br>Area | 121.1 |
| Ağırlık (gr/m)<br>Weight        | 328   |

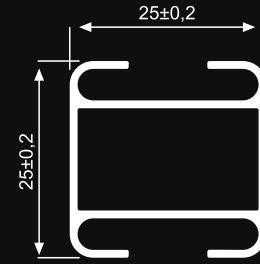

**1871**

|                                 |       |
|---------------------------------|-------|
| Çevre (mm)<br>Perimeter         | 418.8 |
| Alan (mm <sup>2</sup> )<br>Area | 849.8 |
| Ağırlık (gr/m)<br>Weight        | 2303  |

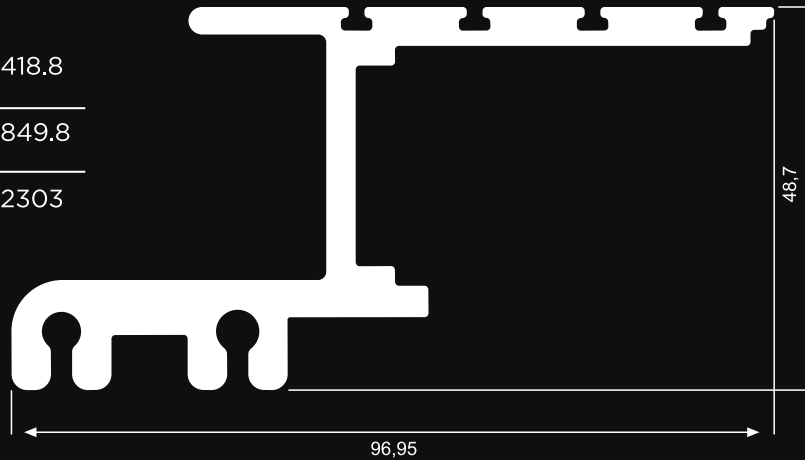

KURUTMALIK PROFİLLERİ  
DRYING PROFILES



Alaşım Alüminyum

|             |                                 |      |
|-------------|---------------------------------|------|
| <b>1872</b> | Çevre (mm)<br>Perimeter         | 297  |
|             | Alan (mm <sup>2</sup> )<br>Area | 607  |
|             | Ağırlık (gr/m)<br>Weight        | 1645 |

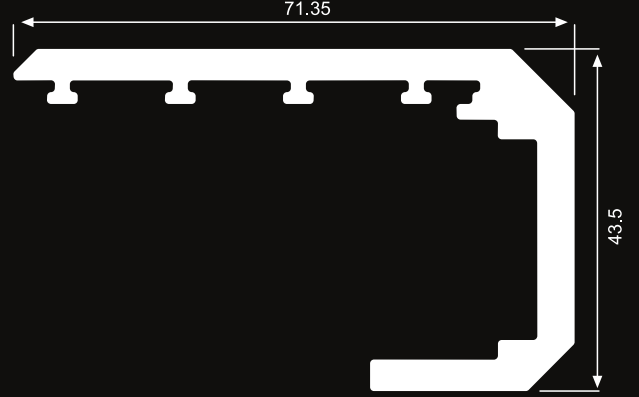

|             |                                 |       |
|-------------|---------------------------------|-------|
| <b>1873</b> | Çevre (mm)<br>Perimeter         | 420.6 |
|             | Alan (mm <sup>2</sup> )<br>Area | 893.2 |
|             | Ağırlık (gr/m)<br>Weight        | 2421  |

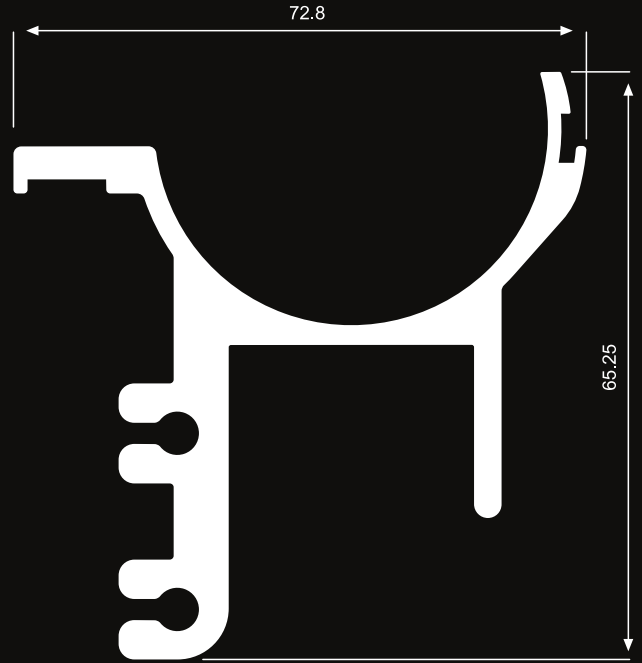

|             |                                 |       |
|-------------|---------------------------------|-------|
| <b>1874</b> | Çevre (mm)<br>Perimeter         | 124.9 |
|             | Alan (mm <sup>2</sup> )<br>Area | 129.2 |
|             | Ağırlık (gr/m)<br>Weight        | 350   |

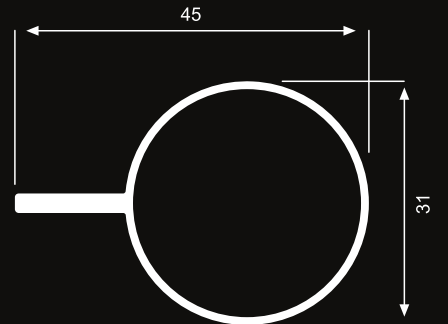





Alaşım Alüminyum

**1875**

|                                 |       |
|---------------------------------|-------|
| Çevre (mm)<br>Perimeter         | 381.1 |
| Alan (mm <sup>2</sup> )<br>Area | 902.7 |
| Ağırlık (gr/m)<br>Weight        | 2446  |

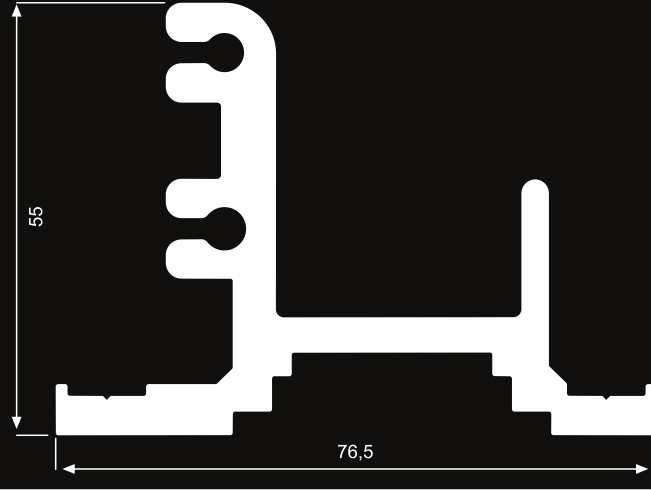

**1876**

|                                 |       |
|---------------------------------|-------|
| Çevre (mm)<br>Perimeter         | 197.7 |
| Alan (mm <sup>2</sup> )<br>Area | 436   |
| Ağırlık (gr/m)<br>Weight        | 1182  |

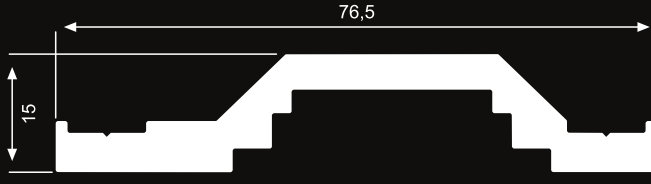

**1877**

|                                 |        |
|---------------------------------|--------|
| Çevre (mm)<br>Perimeter         | 529.8  |
| Alan (mm <sup>2</sup> )<br>Area | 2136.8 |
| Ağırlık (gr/m)<br>Weight        | 5791   |

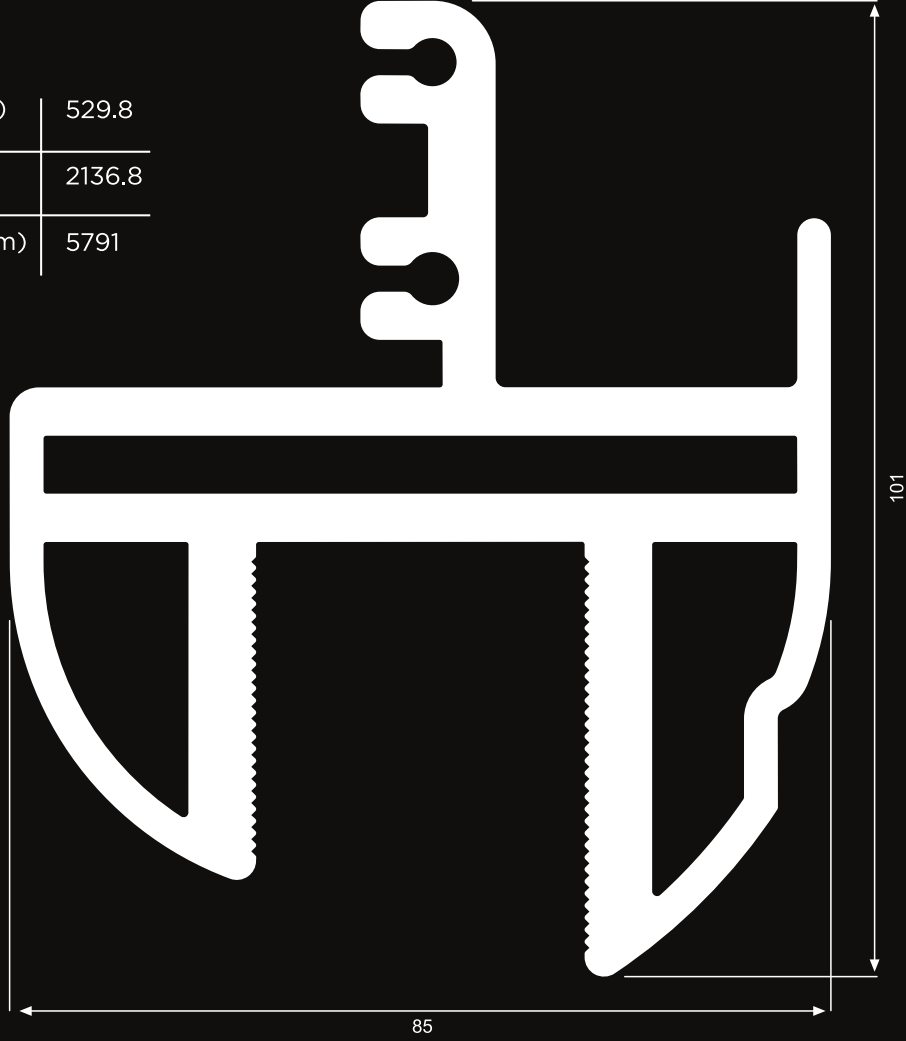

KURUTMALIK PROFİLLERİ  
DRYING PROFILES



Alaşım Alüminyum

|             |  |       |
|-------------|--|-------|
| <b>2232</b> | Çevre (mm)<br><i>Perimeter</i>         | 138.8 |
|             | Alan (mm <sup>2</sup> )<br><i>Area</i> | 396.6 |
|             | Ağırlık (gr/m)<br><i>Weight</i>        | 1075  |

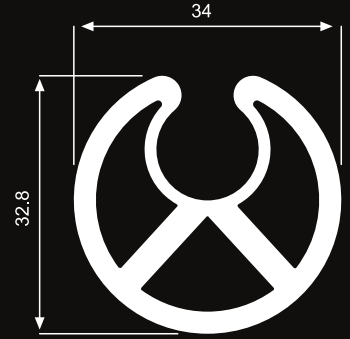

|             |  |       |
|-------------|--|-------|
| <b>2233</b> | Çevre (mm)<br><i>Perimeter</i>         | 224.5 |
|             | Alan (mm <sup>2</sup> )<br><i>Area</i> | 357.5 |
|             | Ağırlık (gr/m)<br><i>Weight</i>        | 969   |

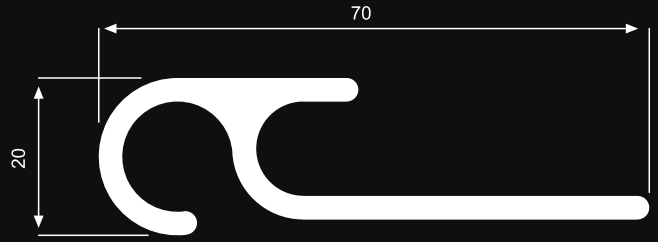

|             |  |       |
|-------------|--|-------|
| <b>2234</b> | Çevre (mm)<br><i>Perimeter</i>         | 117.2 |
|             | Alan (mm <sup>2</sup> )<br><i>Area</i> | 258.6 |
|             | Ağırlık (gr/m)<br><i>Weight</i>        | 701   |

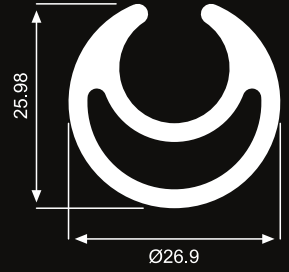

|             |  |       |
|-------------|--|-------|
| <b>2235</b> | Çevre (mm)<br><i>Perimeter</i>         | 143.9 |
|             | Alan (mm <sup>2</sup> )<br><i>Area</i> | 151.9 |
|             | Ağırlık (gr/m)<br><i>Weight</i>        | 412   |

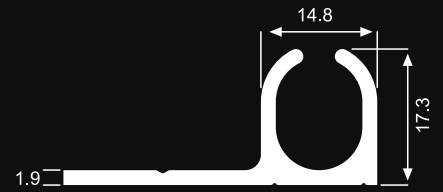

|             |  |       |
|-------------|--|-------|
| <b>2236</b> | Çevre (mm)<br><i>Perimeter</i>         | 180.3 |
|             | Alan (mm <sup>2</sup> )<br><i>Area</i> | 219.9 |
|             | Ağırlık (gr/m)<br><i>Weight</i>        | 596   |



|             |  |       |
|-------------|--|-------|
| <b>2237</b> | Çevre (mm)<br><i>Perimeter</i>         | 146.7 |
|             | Alan (mm <sup>2</sup> )<br><i>Area</i> | 180   |
|             | Ağırlık (gr/m)<br><i>Weight</i>        | 488   |





Alaşım Alüminyum

**2468**

|  |       |
|--|-------|
| Çevre (mm)<br><i>Perimeter</i>         | 229,3 |
| Alan (mm <sup>2</sup> )<br><i>Area</i> | 516,6 |
| Ağırlık (gr/m)<br><i>Weight</i>        | 1400  |

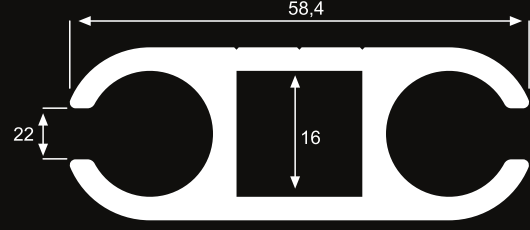

**2238**

|  |       |
|--|-------|
| Çevre (mm)<br><i>Perimeter</i>         | 449.6 |
| Alan (mm <sup>2</sup> )<br><i>Area</i> | 878.3 |
| Ağırlık (gr/m)<br><i>Weight</i>        | 2380  |

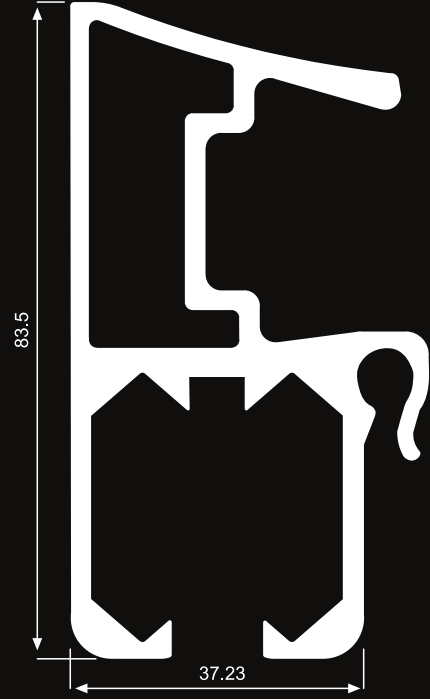

**2239**

|  |       |
|--|-------|
| Çevre (mm)<br><i>Perimeter</i>         | 294.2 |
| Alan (mm <sup>2</sup> )<br><i>Area</i> | 397   |
| Ağırlık (gr/m)<br><i>Weight</i>        | 1076  |

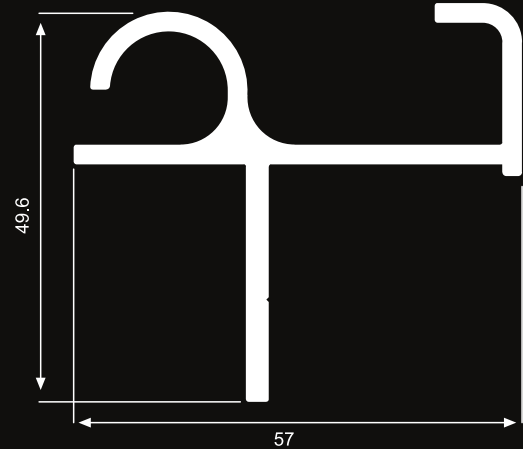

TENTE VE BRANDA PROFİLLERİ  
AWINING PROFILES



Alaşım Alüminyum

|             |                                 |       |
|-------------|---------------------------------|-------|
| <b>2240</b> | Çevre (mm)<br>Perimeter         | 421   |
|             | Alan (mm <sup>2</sup> )<br>Area | 882.5 |
|             | Ağırlık (gr/m)<br>Weight        | 2391  |

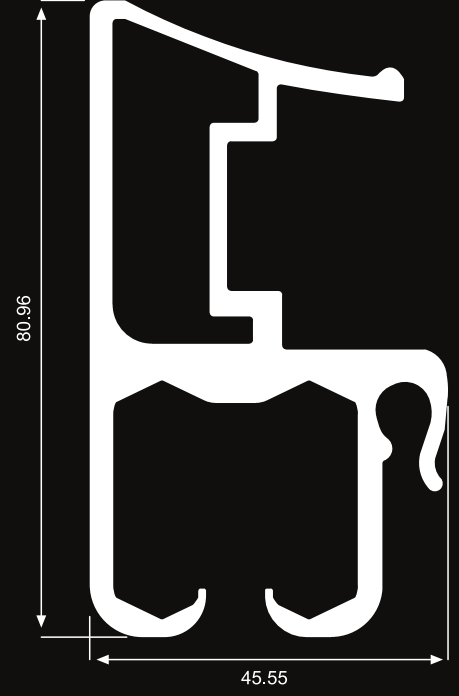

|             |                                 |       |
|-------------|---------------------------------|-------|
| <b>2241</b> | Çevre (mm)<br>Perimeter         | 172.1 |
|             | Alan (mm <sup>2</sup> )<br>Area | 589   |
|             | Ağırlık (gr/m)<br>Weight        | 1596  |

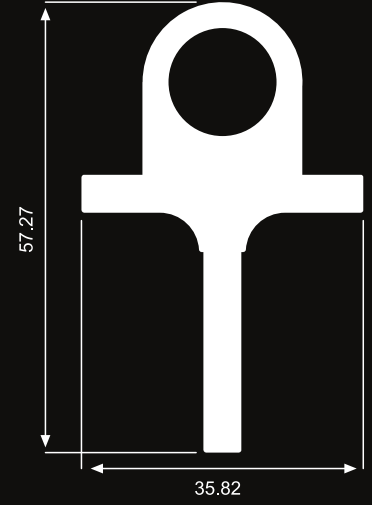

|             |                                 |       |
|-------------|---------------------------------|-------|
| <b>2242</b> | Çevre (mm)<br>Perimeter         | 214.8 |
|             | Alan (mm <sup>2</sup> )<br>Area | 687.4 |
|             | Ağırlık (gr/m)<br>Weight        | 1863  |

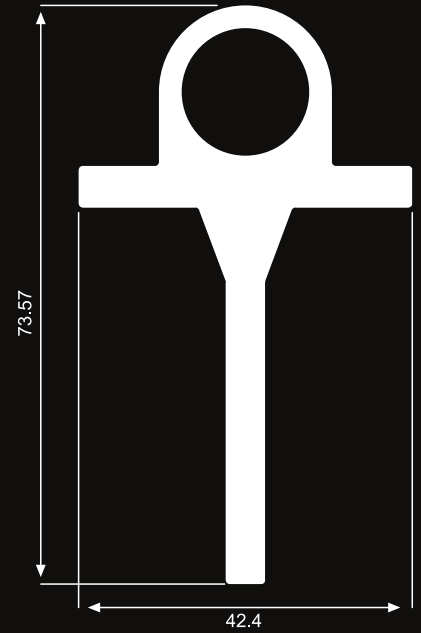



Alaşım Alüminyum

**2247**

|  |      |
|--|------|
| Çevre (mm)<br><i>Perimeter</i>         | 567  |
| Alan (mm <sup>2</sup> )<br><i>Area</i> | 1416 |
| Ağırlık (gr/m)<br><i>Weight</i>        | 3837 |

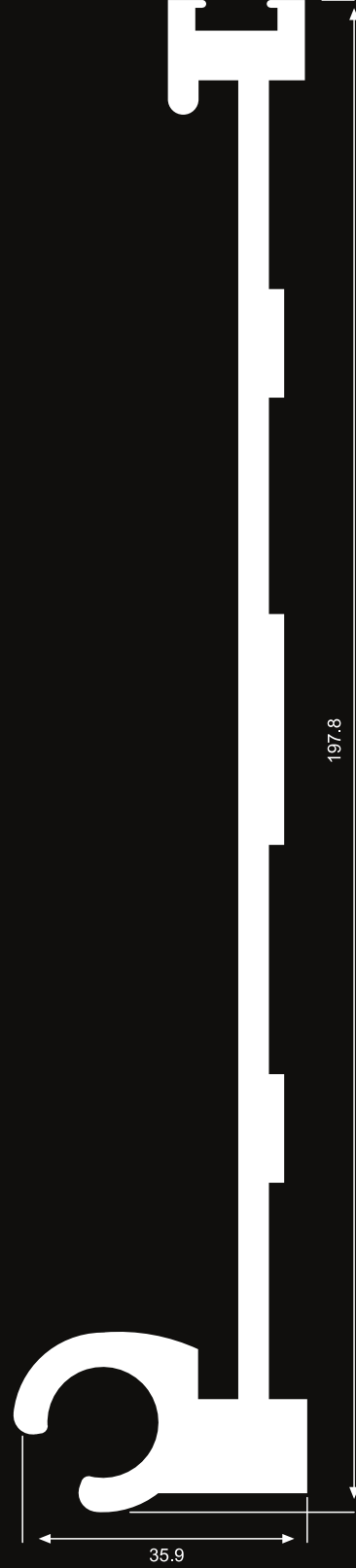

TENTE VE BRANDA PROFİLLERİ  
AWINING PROFILES



## Alaşım Alüminyum

|                |  |       |
|----------------|--|-------|
| <b>2252</b>    | Çevre (mm)<br><i>Perimeter</i>         | 507   |
| * Özel üründür | Alan (mm <sup>2</sup> )<br><i>Area</i> | 452.2 |
|                | Ağırlık (gr/m)<br><i>Weight</i>        | 1225  |

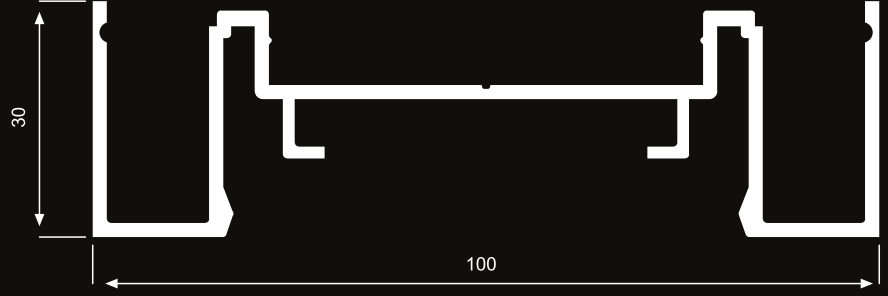

|                |  |       |
|----------------|--|-------|
| <b>2253</b>    | Çevre (mm)<br><i>Perimeter</i>         | 167.1 |
| * Özel üründür | Alan (mm <sup>2</sup> )<br><i>Area</i> | 97.5  |
|                | Ağırlık (gr/m)<br><i>Weight</i>        | 264   |



|                |  |       |
|----------------|--|-------|
| <b>2254</b>    | Çevre (mm)<br><i>Perimeter</i>         | 224.8 |
| * Özel üründür | Alan (mm <sup>2</sup> )<br><i>Area</i> | 306.8 |
|                | Ağırlık (gr/m)<br><i>Weight</i>        | 831   |

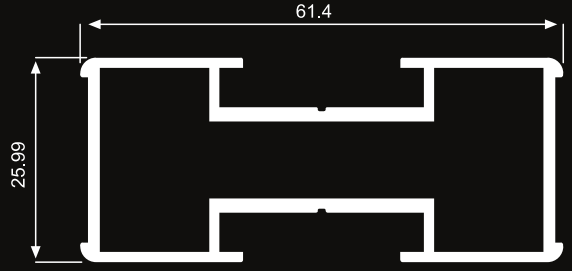

|                |  |       |
|----------------|--|-------|
| <b>2263</b>    | Çevre (mm)<br><i>Perimeter</i>         | 298.6 |
| * Özel üründür | Alan (mm <sup>2</sup> )<br><i>Area</i> | 475.7 |
|                | Ağırlık (gr/m)<br><i>Weight</i>        | 1289  |

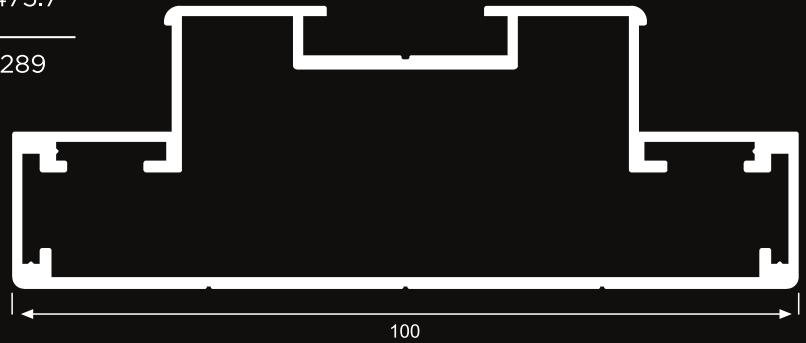



Alaşım Alüminyum

**2255**

Çevre (mm)  
Perimeter

252.4

\* Özel üründür

Alan (mm<sup>2</sup>)  
Area

183

Ağırlık (gr/m)  
Weight

496



**2256**

Çevre (mm)  
Perimeter

248.3

\* Özel üründür

Alan (mm<sup>2</sup>)  
Area

208.9

Ağırlık (gr/m)  
Weight

566

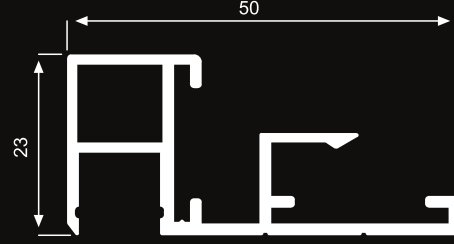

**2257**

Çevre (mm)  
Perimeter

315.5

\* Özel üründür

Alan (mm<sup>2</sup>)  
Area

602.5

Ağırlık (gr/m)  
Weight

1633

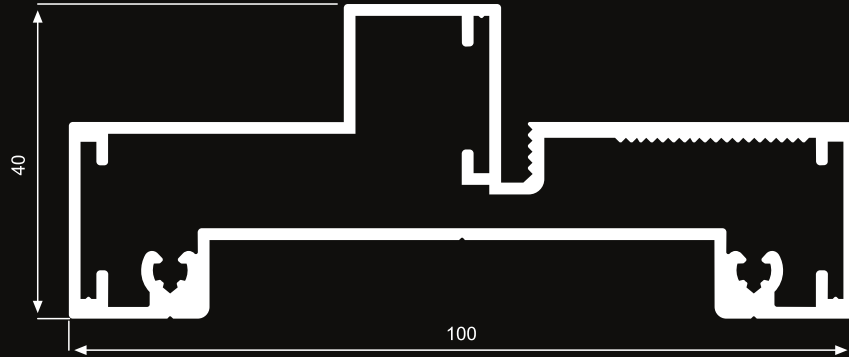

**2258**

Çevre (mm)  
Perimeter

104

\* Özel üründür

Alan (mm<sup>2</sup>)  
Area

61.3

Ağırlık (gr/m)  
Weight

166

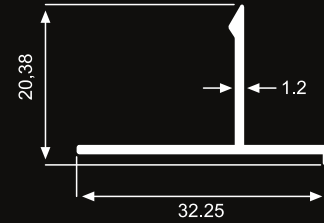

**2259**

Çevre (mm)  
Perimeter

245.4

\* Özel üründür

Alan (mm<sup>2</sup>)  
Area

167

Ağırlık (gr/m)  
Weight

453

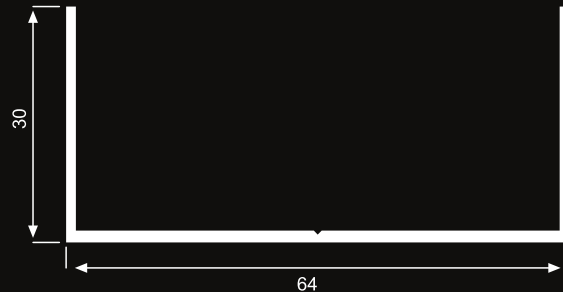

OFİS BÖLME PROFİLLERİ  
OFFICE PARTITION PROFILES



Alaşım Alüminyum

**2260**

\* Özel üründür

Çevre (mm)  
Perimeter

305.4

Alan (mm<sup>2</sup>)  
Area

204.5

Ağırlık (gr/m)  
Weight

554

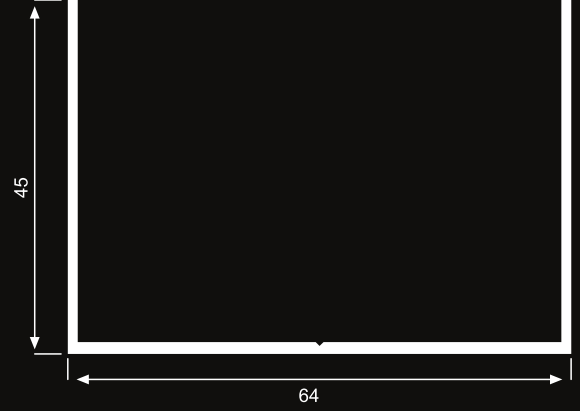

**2261**

\* Özel üründür

Çevre (mm)  
Perimeter

425.4

Alan (mm<sup>2</sup>)  
Area

279.5

Ağırlık (gr/m)  
Weight

757

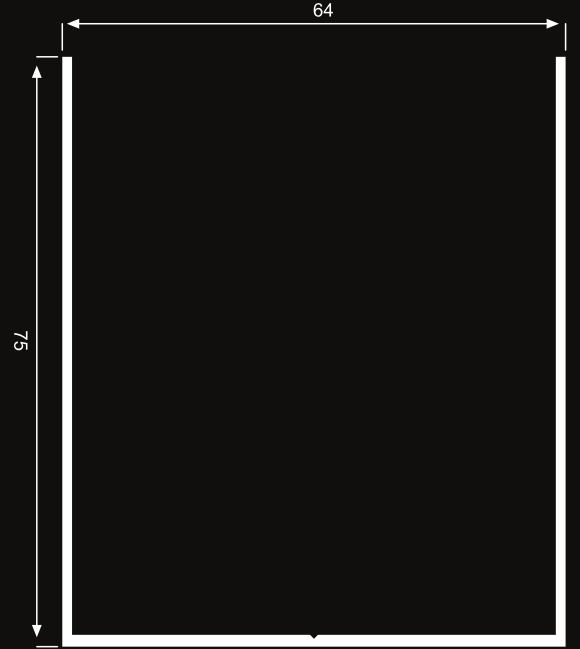

**2262**

\* Özel üründür

Çevre (mm)  
Perimeter

383.8

Alan (mm<sup>2</sup>)  
Area

282.3

Ağırlık (gr/m)  
Weight

765







Alaşım Alüminyum

**2264**

|                                 |       |
|---------------------------------|-------|
| Çevre (mm)<br>Perimeter         | 558.2 |
| Alan (mm <sup>2</sup> )<br>Area | 728.6 |
| Ağırlık (gr/m)<br>Weight        | 1975  |

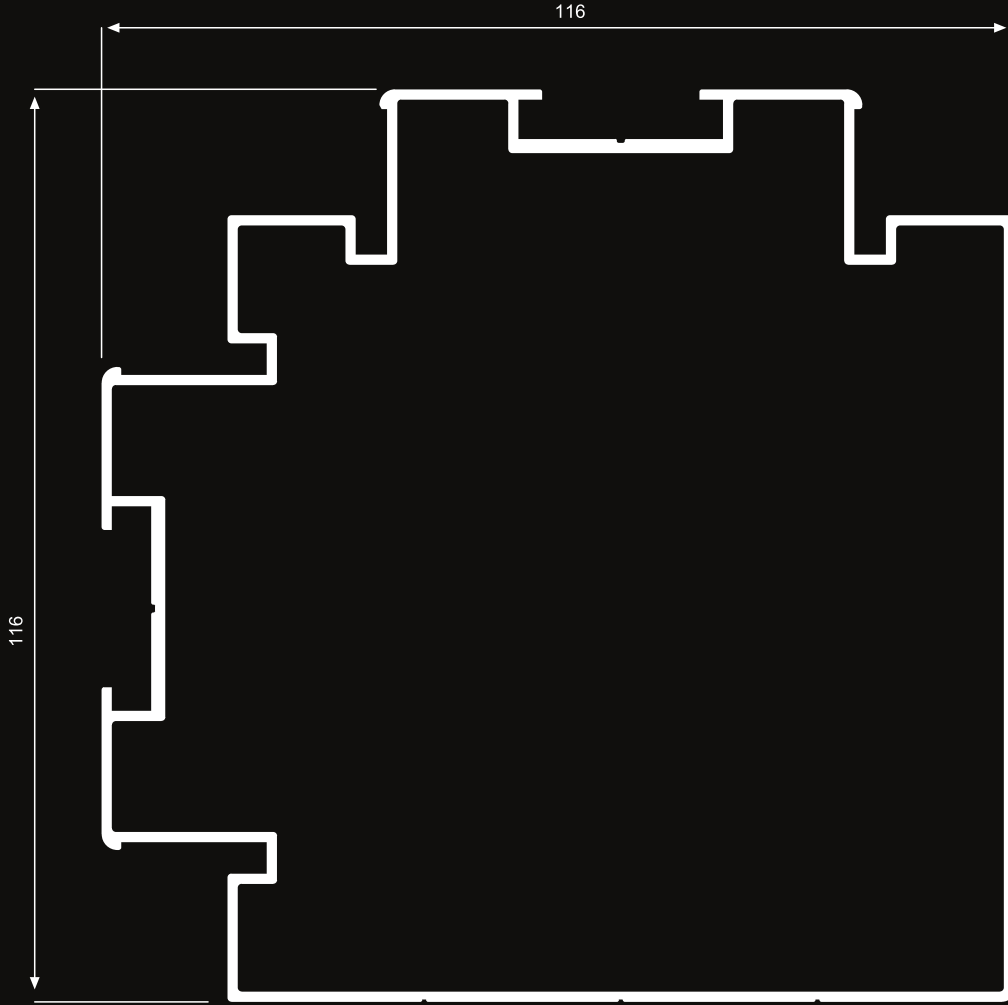

OFİS BÖLME PROFİLLERİ  
OFFICE PARTITION PROFILES



Alaşım Alüminyum

|                |                                 |       |
|----------------|---------------------------------|-------|
| <b>2285</b>    | Çevre (mm)<br>Perimeter         | 366,7 |
| * Özel üründür | Alan (mm <sup>2</sup> )<br>Area | 302,2 |
|                | Ağırlık (gr/m)<br>Weight        | 819   |

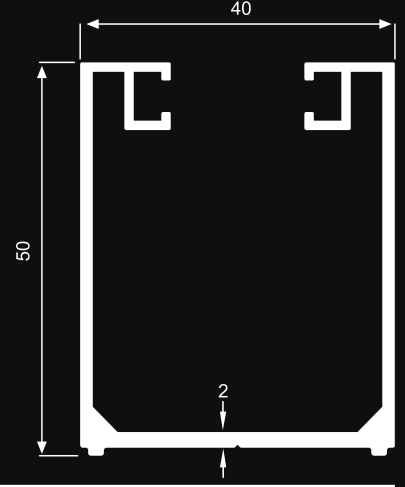

|                |                                 |       |
|----------------|---------------------------------|-------|
| <b>2286</b>    | Çevre (mm)<br>Perimeter         | 249,7 |
| * Özel üründür | Alan (mm <sup>2</sup> )<br>Area | 280,3 |
|                | Ağırlık (gr/m)<br>Weight        | 759   |

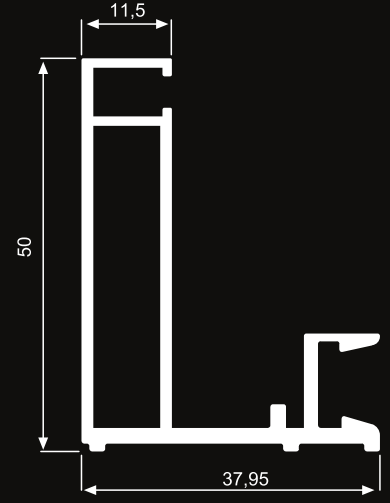

|                |                                 |       |
|----------------|---------------------------------|-------|
| <b>2287</b>    | Çevre (mm)<br>Perimeter         | 178,2 |
| * Özel üründür | Alan (mm <sup>2</sup> )<br>Area | 123,5 |
|                | Ağırlık (gr/m)<br>Weight        | 335   |

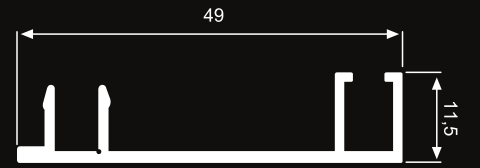

|                |                                 |       |
|----------------|---------------------------------|-------|
| <b>2288</b>    | Çevre (mm)<br>Perimeter         | 207,5 |
| * Özel üründür | Alan (mm <sup>2</sup> )<br>Area | 374,5 |
|                | Ağırlık (gr/m)<br>Weight        | 1015  |

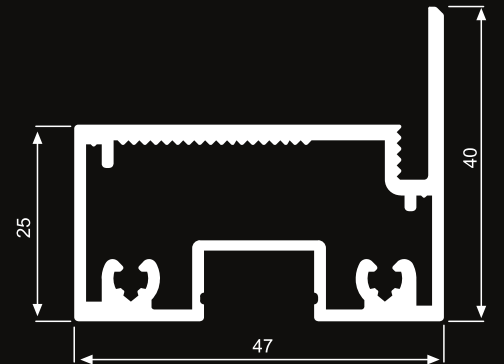



Alaşım Alüminyum

**2289**

\* Özel üründür

|                                 |       |
|---------------------------------|-------|
| Çevre (mm)<br>Perimeter         | 317,7 |
| Alan (mm <sup>2</sup> )<br>Area | 380,2 |
| Ağırlık (gr/m)<br>Weight        | 1030  |



**2290**

\* Özel üründür

|                                 |      |
|---------------------------------|------|
| Çevre (mm)<br>Perimeter         | 93,2 |
| Alan (mm <sup>2</sup> )<br>Area | 110  |
| Ağırlık (gr/m)<br>Weight        | 298  |

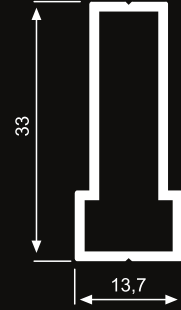

**2291**

\* Özel üründür

|                                 |       |
|---------------------------------|-------|
| Çevre (mm)<br>Perimeter         | 139,2 |
| Alan (mm <sup>2</sup> )<br>Area | 302,6 |
| Ağırlık (gr/m)<br>Weight        | 820   |

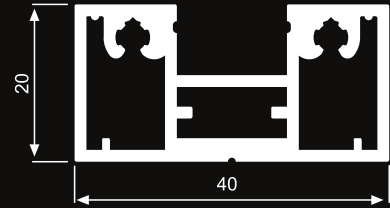

**2292**

\* Özel üründür

|                                 |       |
|---------------------------------|-------|
| Çevre (mm)<br>Perimeter         | 430,2 |
| Alan (mm <sup>2</sup> )<br>Area | 386,7 |
| Ağırlık (gr/m)<br>Weight        | 1048  |

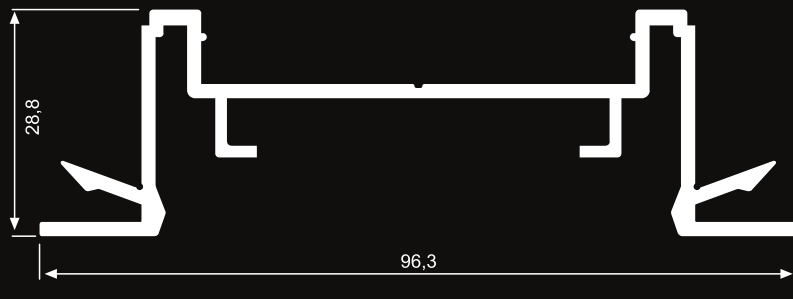

OFİS BÖLME PROFİLLERİ  
OFFICE PARTITION PROFILES



Alaşım Alüminyum

**2293**

|  |      |
|--|------|
| Çevre (mm)<br><i>Perimeter</i>         | 88,2 |
| Alan (mm <sup>2</sup> )<br><i>Area</i> | 74,4 |
| Ağırlık (gr/m)<br><i>Weight</i>        | 202  |

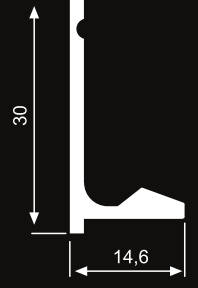

**2329**

|  |       |
|--|-------|
| Çevre (mm)<br><i>Perimeter</i>         | 168,8 |
| Alan (mm <sup>2</sup> )<br><i>Area</i> | 266,4 |
| Ağırlık (gr/m)<br><i>Weight</i>        | 722   |

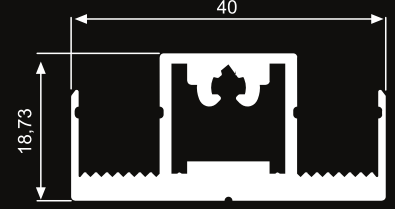

**2330**

|  |       |
|--|-------|
| Çevre (mm)<br><i>Perimeter</i>         | 216,8 |
| Alan (mm <sup>2</sup> )<br><i>Area</i> | 200,2 |
| Ağırlık (gr/m)<br><i>Weight</i>        | 542   |



**2342**

|  |       |
|--|-------|
| Çevre (mm)<br><i>Perimeter</i>         | 219,1 |
| Alan (mm <sup>2</sup> )<br><i>Area</i> | 299,5 |
| Ağırlık (gr/m)<br><i>Weight</i>        | 811   |

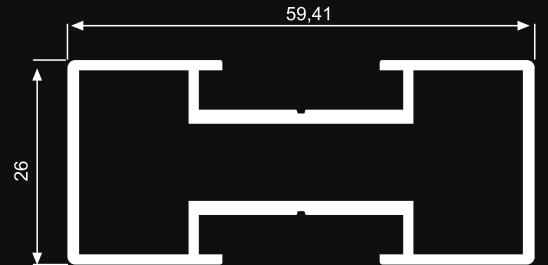



Alaşım Alüminyum

**2354**

|                                 |       |
|---------------------------------|-------|
| Çevre (mm)<br>Perimeter         | 181,2 |
| Alan (mm <sup>2</sup> )<br>Area | 128,4 |
| Ağırlık (gr/m)<br>Weight        | 347   |



**2355**

|                                 |       |
|---------------------------------|-------|
| Çevre (mm)<br>Perimeter         | 284,6 |
| Alan (mm <sup>2</sup> )<br>Area | 638,8 |
| Ağırlık (gr/m)<br>Weight        | 1731  |

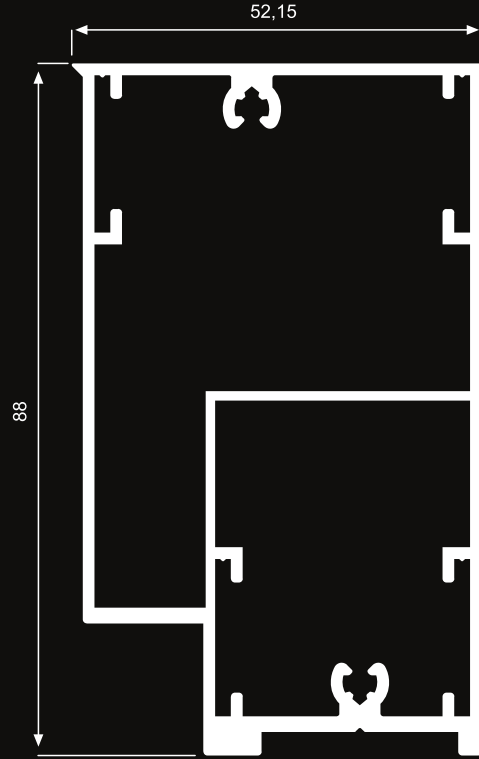

**2383**

|                                 |       |
|---------------------------------|-------|
| Çevre (mm)<br>Perimeter         | 160,9 |
| Alan (mm <sup>2</sup> )<br>Area | 171,5 |
| Ağırlık (gr/m)<br>Weight        | 464   |

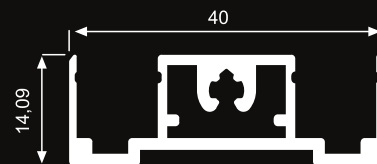

OFİS BÖLME PROFİLLERİ  
OFFICE PARTITION PROFILES



Alaşım Alüminyum

|             |  |       |
|-------------|--|-------|
| <b>2461</b> | Çevre (mm)<br><i>Perimeter</i>         | 354,1 |
|             | Alan (mm <sup>2</sup> )<br><i>Area</i> | 337,3 |
|             | Ağırlık (gr/m)<br><i>Weight</i>        | 914   |

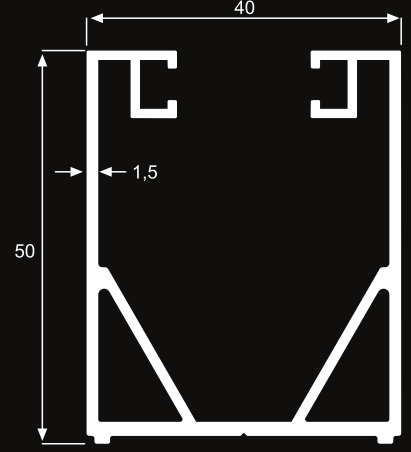

|             |  |       |
|-------------|--|-------|
| <b>2476</b> | Çevre (mm)<br><i>Perimeter</i>         | 538,2 |
|             | Alan (mm <sup>2</sup> )<br><i>Area</i> | 530   |
|             | Ağırlık (gr/m)<br><i>Weight</i>        | 1436  |

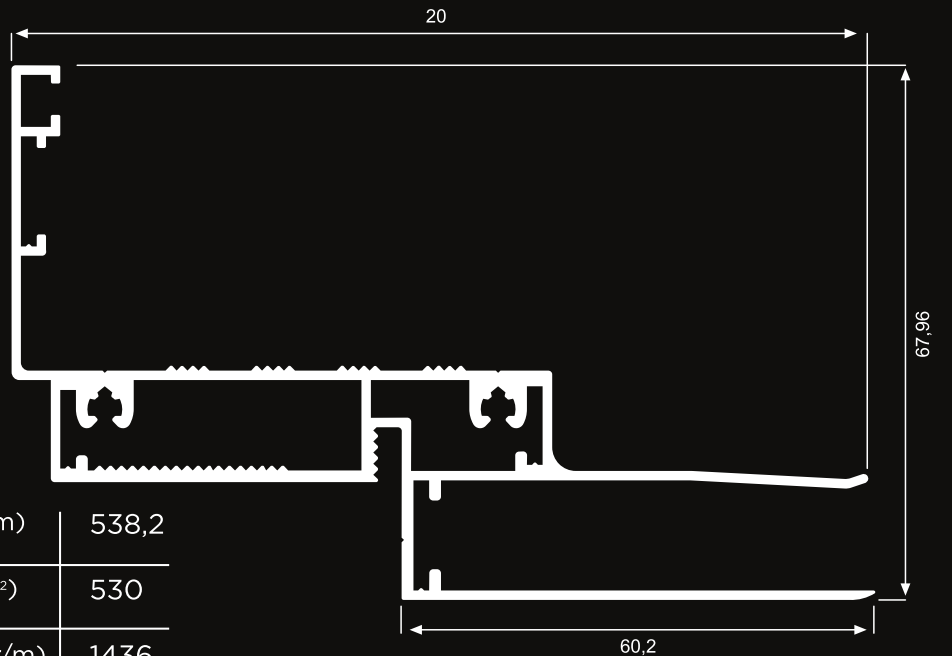



Alaşım Alüminyum

**2477**

|                                 |       |
|---------------------------------|-------|
| Çevre (mm)<br>Perimeter         | 153,6 |
| Alan (mm <sup>2</sup> )<br>Area | 171,7 |
| Ağırlık (gr/m)<br>Weight        | 465   |

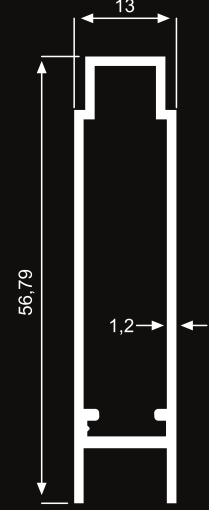

**2478**

|                                 |       |
|---------------------------------|-------|
| Çevre (mm)<br>Perimeter         | 304,1 |
| Alan (mm <sup>2</sup> )<br>Area | 297   |
| Ağırlık (gr/m)<br>Weight        | 804   |

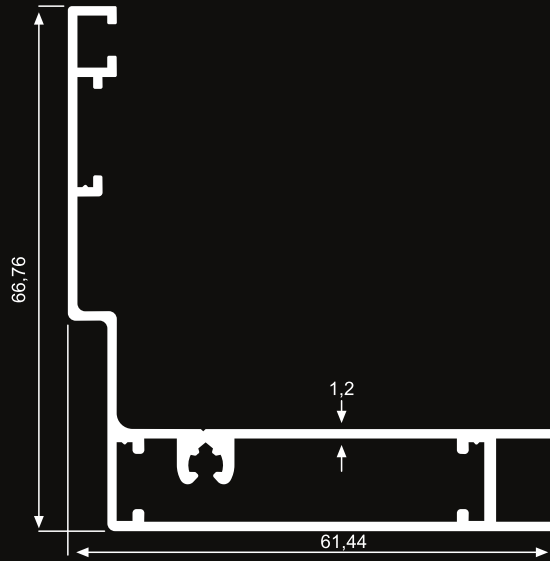

OFİS BÖLME PROFİLLERİ  
OFFICE PARTITION PROFILES



Alaşım Alüminyum

|             |                                 |     |
|-------------|---------------------------------|-----|
| <b>2216</b> | Çevre (mm)<br>Perimeter         | 260 |
|             | Alan (mm <sup>2</sup> )<br>Area | 303 |
|             | Ağırlık (gr/m)<br>Weight        | 705 |

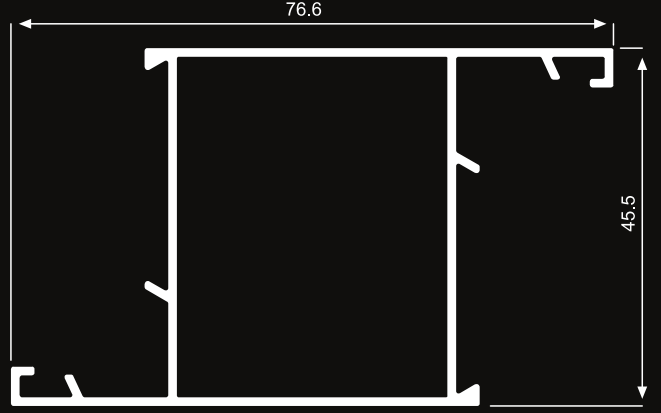

|             |                                 |     |
|-------------|---------------------------------|-----|
| <b>2217</b> | Çevre (mm)<br>Perimeter         | 303 |
|             | Alan (mm <sup>2</sup> )<br>Area | 260 |
|             | Ağırlık (gr/m)<br>Weight        | 705 |

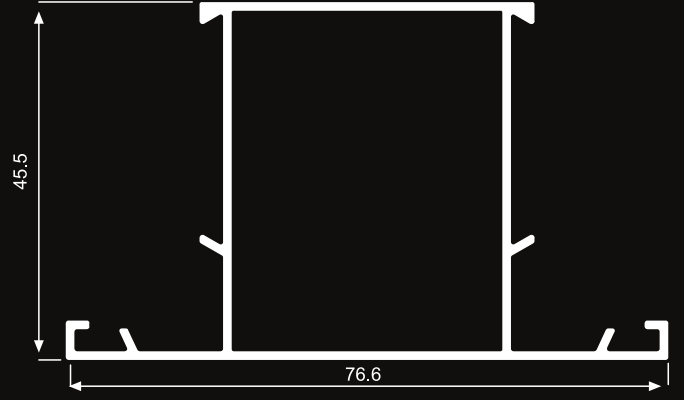

|             |                                 |     |
|-------------|---------------------------------|-----|
| <b>2218</b> | Çevre (mm)<br>Perimeter         | 241 |
|             | Alan (mm <sup>2</sup> )<br>Area | 223 |
|             | Ağırlık (gr/m)<br>Weight        | 604 |

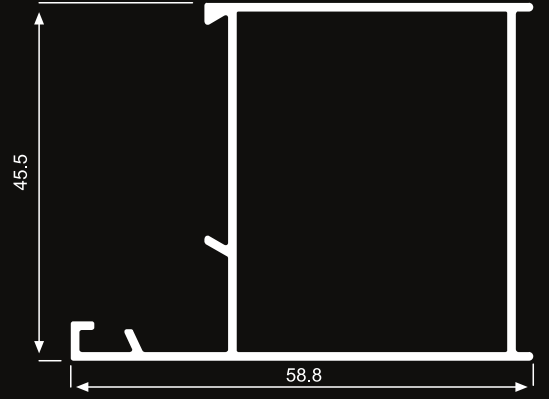

|             |                                 |     |
|-------------|---------------------------------|-----|
| <b>2219</b> | Çevre (mm)<br>Perimeter         | 151 |
|             | Alan (mm <sup>2</sup> )<br>Area | 90  |
|             | Ağırlık (gr/m)<br>Weight        | 244 |

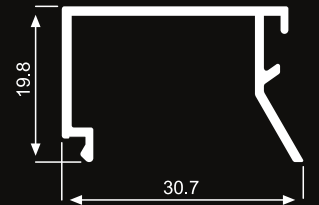





Alaşım Alüminyum

|             |  |     |
|-------------|--|-----|
| <b>2220</b> | Çevre (mm)<br><i>Perimeter</i>         | 144 |
|             | Alan (mm <sup>2</sup> )<br><i>Area</i> | 75  |
|             | Ağırlık (gr/m)<br><i>Weight</i>        | 203 |

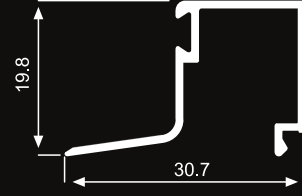

|             |  |      |
|-------------|--|------|
| <b>2221</b> | Çevre (mm)<br><i>Perimeter</i>         | 358  |
|             | Alan (mm <sup>2</sup> )<br><i>Area</i> | 414  |
|             | Ağırlık (gr/m)<br><i>Weight</i>        | 1122 |

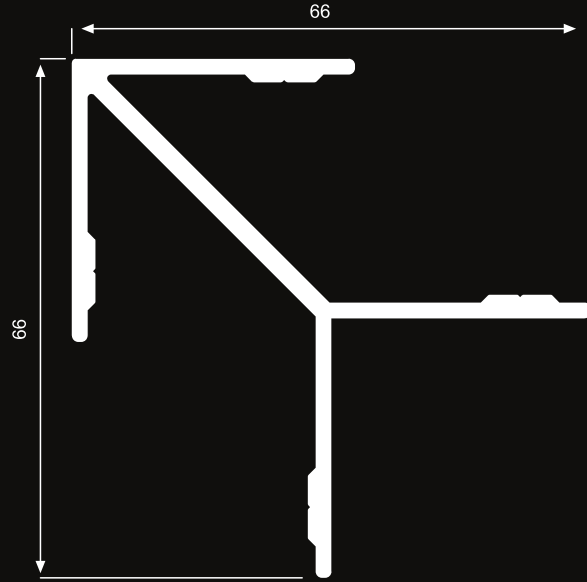

|             |  |     |
|-------------|--|-----|
| <b>2222</b> | Çevre (mm)<br><i>Perimeter</i>         | 202 |
|             | Alan (mm <sup>2</sup> )<br><i>Area</i> | 282 |
|             | Ağırlık (gr/m)<br><i>Weight</i>        | 764 |

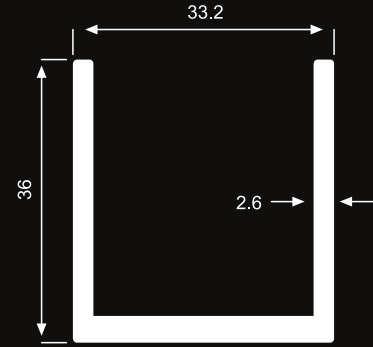

|             |  |    |
|-------------|--|----|
| <b>2223</b> | Çevre (mm)<br><i>Perimeter</i>         | 55 |
|             | Alan (mm <sup>2</sup> )<br><i>Area</i> | 36 |
|             | Ağırlık (gr/m)<br><i>Weight</i>        | 98 |



|             |  |     |
|-------------|--|-----|
| <b>2224</b> | Çevre (mm)<br><i>Perimeter</i>         | 80  |
|             | Alan (mm <sup>2</sup> )<br><i>Area</i> | 47  |
|             | Ağırlık (gr/m)<br><i>Weight</i>        | 127 |



PENCERE - ALDOKS PROFİLLERİ  
WINDOW - ALDOKS PROFILES



Alaşım Alüminyum

|             |  |       |
|-------------|--|-------|
| <b>2400</b> | Çevre (mm)<br><i>Perimeter</i>         | 336,6 |
|             | Alan (mm <sup>2</sup> )<br><i>Area</i> | 416,4 |
|             | Ağırlık (gr/m)<br><i>Weight</i>        | 1128  |

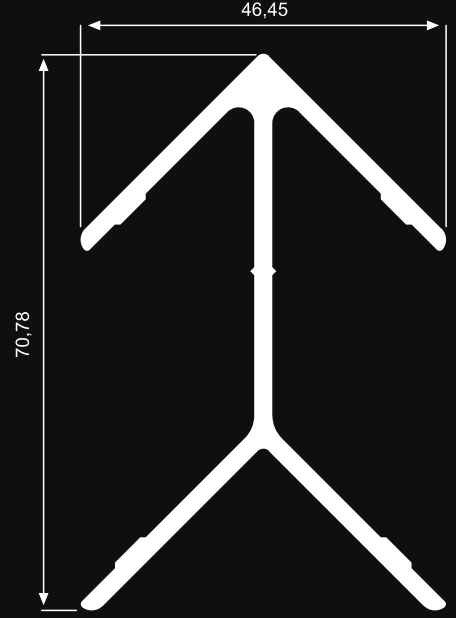

|             |  |       |
|-------------|--|-------|
| <b>2401</b> | Çevre (mm)<br><i>Perimeter</i>         | 326,6 |
|             | Alan (mm <sup>2</sup> )<br><i>Area</i> | 431,3 |
|             | Ağırlık (gr/m)<br><i>Weight</i>        | 1168  |

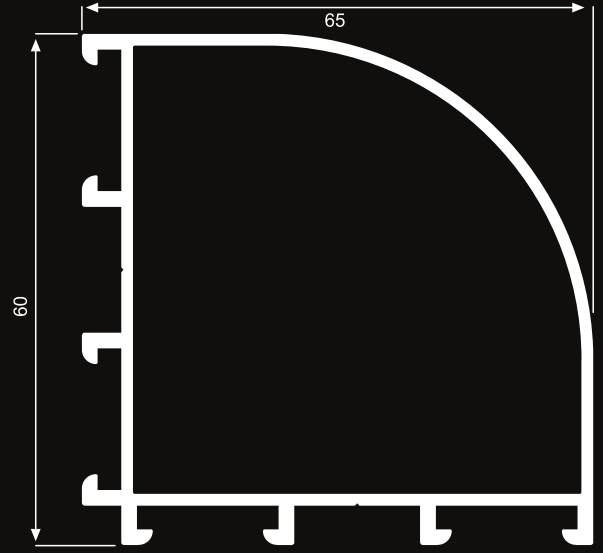

|             |  |       |
|-------------|--|-------|
| <b>2402</b> | Çevre (mm)<br><i>Perimeter</i>         | 333,6 |
|             | Alan (mm <sup>2</sup> )<br><i>Area</i> | 379,9 |
|             | Ağırlık (gr/m)<br><i>Weight</i>        | 1029  |

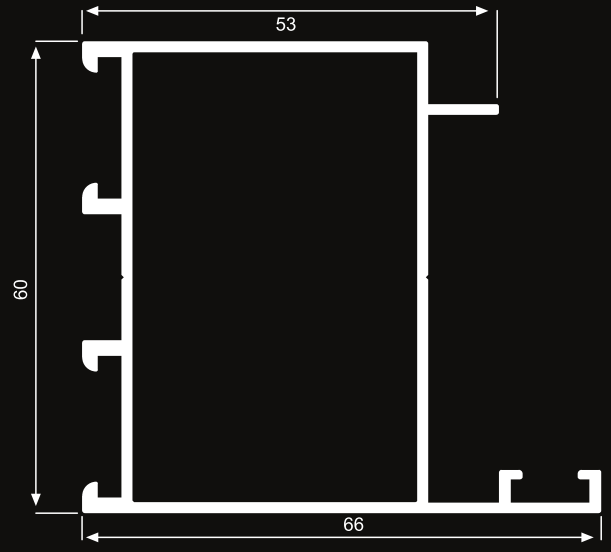



Alaşım Alüminyum

**2403**

|  |       |
|--|-------|
| Çevre (mm)<br><i>Perimeter</i>         | 302,4 |
| Alan (mm <sup>2</sup> )<br><i>Area</i> | 375,4 |
| Ağırlık (gr/m)<br><i>Weight</i>        | 1017  |

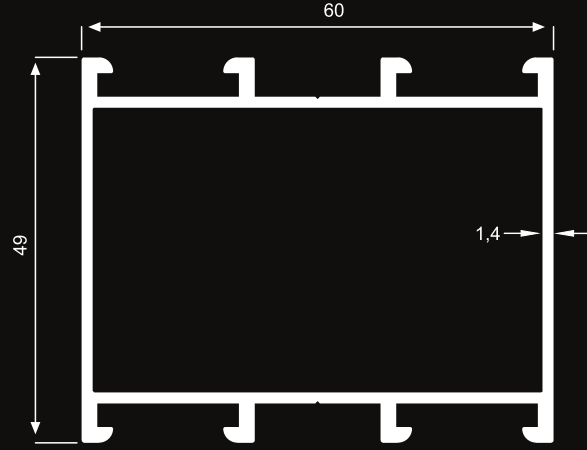

**2404**

|  |       |
|--|-------|
| Çevre (mm)<br><i>Perimeter</i>         | 130,5 |
| Alan (mm <sup>2</sup> )<br><i>Area</i> | 84,1  |
| Ağırlık (gr/m)<br><i>Weight</i>        | 228   |

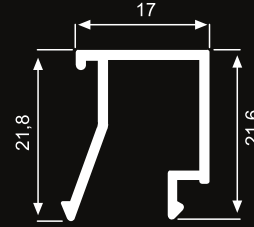

**2405**

|  |       |
|--|-------|
| Çevre (mm)<br><i>Perimeter</i>         | 142,3 |
| Alan (mm <sup>2</sup> )<br><i>Area</i> | 86    |
| Ağırlık (gr/m)<br><i>Weight</i>        | 233   |

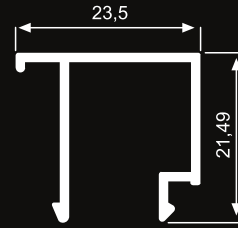

**2406**

|  |       |
|--|-------|
| Çevre (mm)<br><i>Perimeter</i>         | 220,7 |
| Alan (mm <sup>2</sup> )<br><i>Area</i> | 156,2 |
| Ağırlık (gr/m)<br><i>Weight</i>        | 423   |

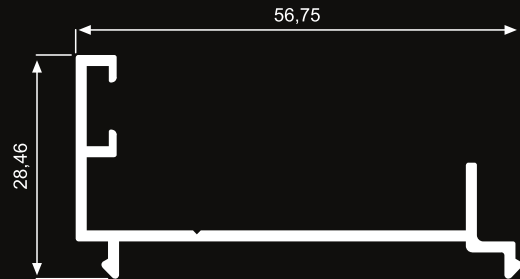



Alaşım Alüminyum

|             |  |      |
|-------------|--|------|
| <b>2107</b> | Çevre (mm)<br><i>Perimeter</i>         | 413  |
|             | Alan (mm <sup>2</sup> )<br><i>Area</i> | 541  |
|             | Ağırlık (gr/m)<br><i>Weight</i>        | 1466 |

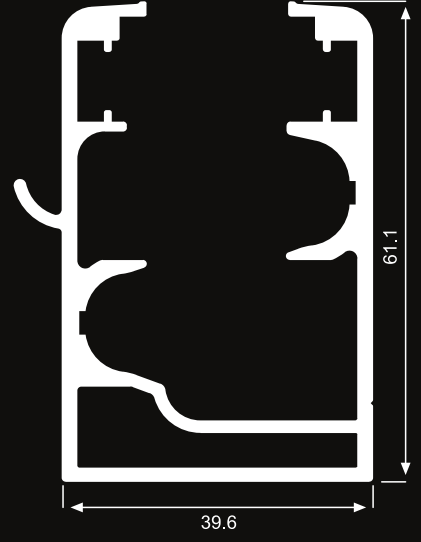

|             |  |      |
|-------------|--|------|
| <b>2108</b> | Çevre (mm)<br><i>Perimeter</i>         | 398  |
|             | Alan (mm <sup>2</sup> )<br><i>Area</i> | 528  |
|             | Ağırlık (gr/m)<br><i>Weight</i>        | 1431 |

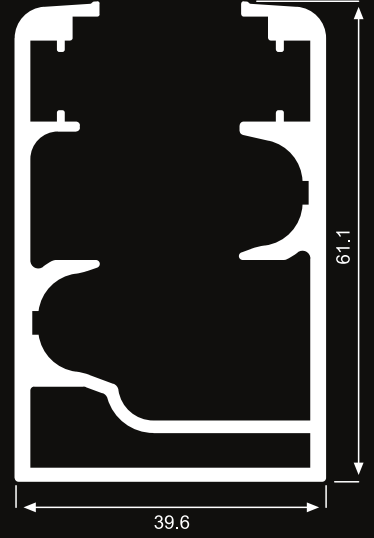

|             |  |     |
|-------------|--|-----|
| <b>2109</b> | Çevre (mm)<br><i>Perimeter</i>         | 288 |
|             | Alan (mm <sup>2</sup> )<br><i>Area</i> | 320 |
|             | Ağırlık (gr/m)<br><i>Weight</i>        | 867 |

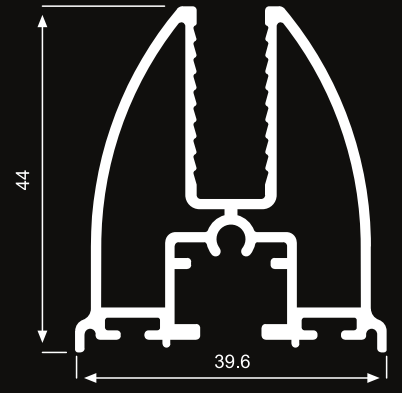



Alaşım Alüminyum

|             |  |     |
|-------------|--|-----|
| <b>2110</b> | Çevre (mm)<br><i>Perimeter</i>         | 164 |
|             | Alan (mm <sup>2</sup> )<br><i>Area</i> | 179 |
|             | Ağırlık (gr/m)<br><i>Weight</i>        | 485 |

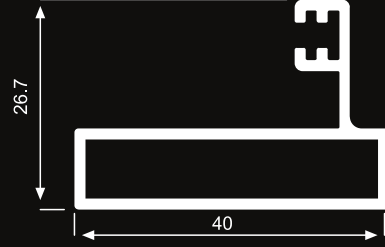

|             |  |     |
|-------------|--|-----|
| <b>2111</b> | Çevre (mm)<br><i>Perimeter</i>         | 147 |
|             | Alan (mm <sup>2</sup> )<br><i>Area</i> | 83  |
|             | Ağırlık (gr/m)<br><i>Weight</i>        | 225 |

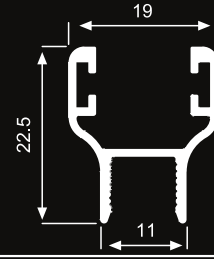

|             |  |     |
|-------------|--|-----|
| <b>2112</b> | Çevre (mm)<br><i>Perimeter</i>         | 94  |
|             | Alan (mm <sup>2</sup> )<br><i>Area</i> | 63  |
|             | Ağırlık (gr/m)<br><i>Weight</i>        | 171 |

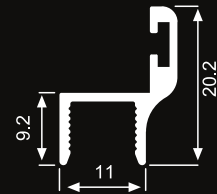



Alaşım Alüminyum

|             |  |       |
|-------------|--|-------|
| <b>2386</b> | Çevre (mm)<br><i>Perimeter</i>         | 207,5 |
|             | Alan (mm <sup>2</sup> )<br><i>Area</i> | 262,1 |
|             | Ağırlık (gr/m)<br><i>Weight</i>        | 713   |

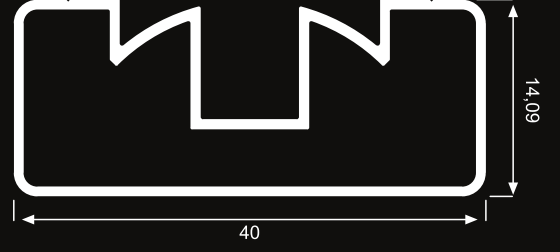

|             |  |     |
|-------------|--|-----|
| <b>2387</b> | Çevre (mm)<br><i>Perimeter</i>         | 53  |
|             | Alan (mm <sup>2</sup> )<br><i>Area</i> | 59  |
|             | Ağırlık (gr/m)<br><i>Weight</i>        | 160 |

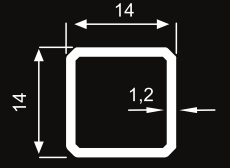

|             |  |       |
|-------------|--|-------|
| <b>2388</b> | Çevre (mm)<br><i>Perimeter</i>         | 219,6 |
|             | Alan (mm <sup>2</sup> )<br><i>Area</i> | 216,1 |
|             | Ağırlık (gr/m)<br><i>Weight</i>        | 585   |

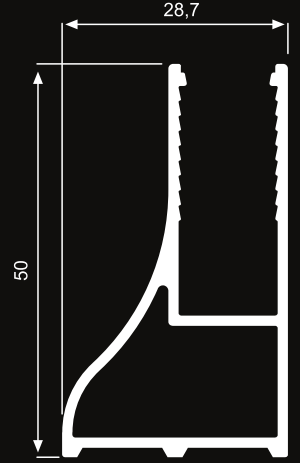

|             |  |       |
|-------------|--|-------|
| <b>2389</b> | Çevre (mm)<br><i>Perimeter</i>         | 178,7 |
|             | Alan (mm <sup>2</sup> )<br><i>Area</i> | 277,8 |
|             | Ağırlık (gr/m)<br><i>Weight</i>        | 753   |

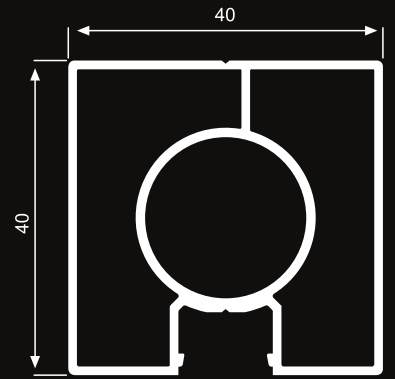

|             |  |       |
|-------------|--|-------|
| <b>2390</b> | Çevre (mm)<br><i>Perimeter</i>         | 120,4 |
|             | Alan (mm <sup>2</sup> )<br><i>Area</i> | 94    |
|             | Ağırlık (gr/m)<br><i>Weight</i>        | 254   |

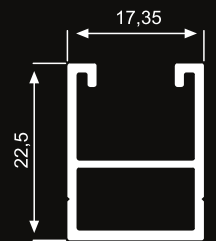



Alaşım Alüminyum

**2391**

|                                 |       |
|---------------------------------|-------|
| Çevre (mm)<br>Perimeter         | 214,3 |
| Alan (mm <sup>2</sup> )<br>Area | 237,6 |
| Ağırlık (gr/m)<br>Weight        | 643   |

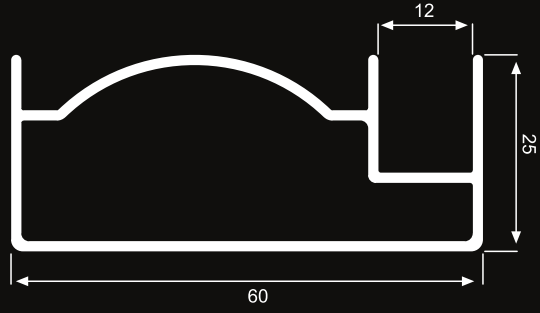

**2392**

|                                 |       |
|---------------------------------|-------|
| Çevre (mm)<br>Perimeter         | 308   |
| Alan (mm <sup>2</sup> )<br>Area | 337,8 |
| Ağırlık (gr/m)<br>Weight        | 915   |

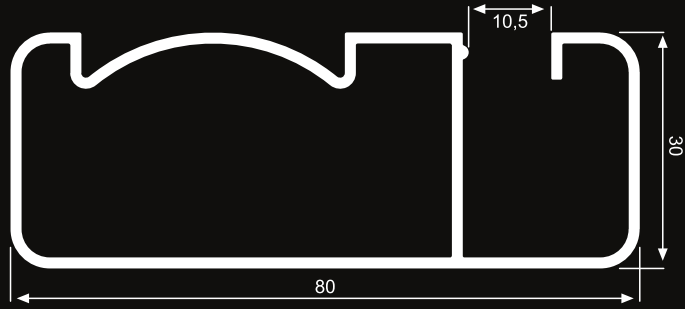

**2393**

|                                 |       |
|---------------------------------|-------|
| Çevre (mm)<br>Perimeter         | 265,6 |
| Alan (mm <sup>2</sup> )<br>Area | 271,9 |
| Ağırlık (gr/m)<br>Weight        | 737   |

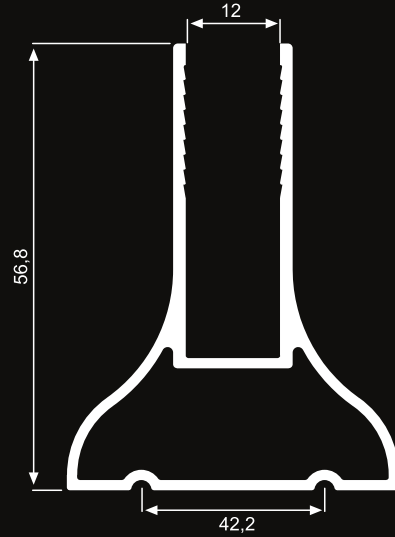

**2394**

|                                 |      |
|---------------------------------|------|
| Çevre (mm)<br>Perimeter         | 38,7 |
| Alan (mm <sup>2</sup> )<br>Area | 17,2 |
| Ağırlık (gr/m)<br>Weight        | 46   |

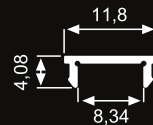

**2414**

|                                 |      |
|---------------------------------|------|
| Çevre (mm)<br>Perimeter         | 57,1 |
| Alan (mm <sup>2</sup> )<br>Area | 32,1 |
| Ağırlık (gr/m)<br>Weight        | 87   |

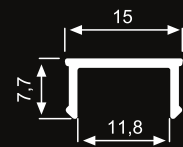

KÜPEŞTE PROFİLLERİ  
HANDRAIL PROFILES



Alaşım Alüminyum

|             |  |       |
|-------------|--|-------|
| <b>2415</b> | Çevre (mm)<br><i>Perimeter</i>         | 240,1 |
|             | Alan (mm <sup>2</sup> )<br><i>Area</i> | 193,1 |
|             | Ağırlık (gr/m)<br><i>Weight</i>        | 523   |

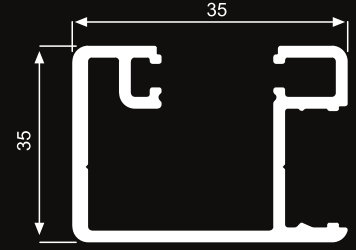

|             |  |       |
|-------------|--|-------|
| <b>2416</b> | Çevre (mm)<br><i>Perimeter</i>         | 254,5 |
|             | Alan (mm <sup>2</sup> )<br><i>Area</i> | 370,8 |
|             | Ağırlık (gr/m)<br><i>Weight</i>        | 1004  |

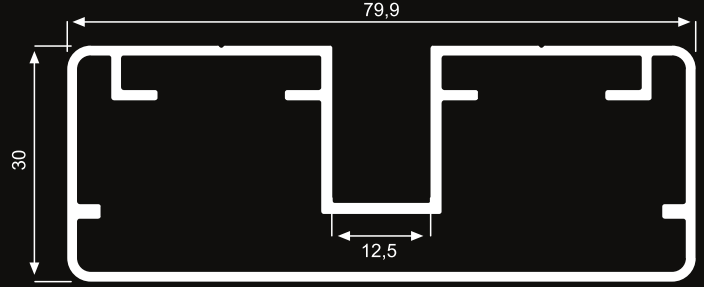

|             |  |       |
|-------------|--|-------|
| <b>2441</b> | Çevre (mm)<br><i>Perimeter</i>         | 179,3 |
|             | Alan (mm <sup>2</sup> )<br><i>Area</i> | 211   |
|             | Ağırlık (gr/m)<br><i>Weight</i>        | 572   |

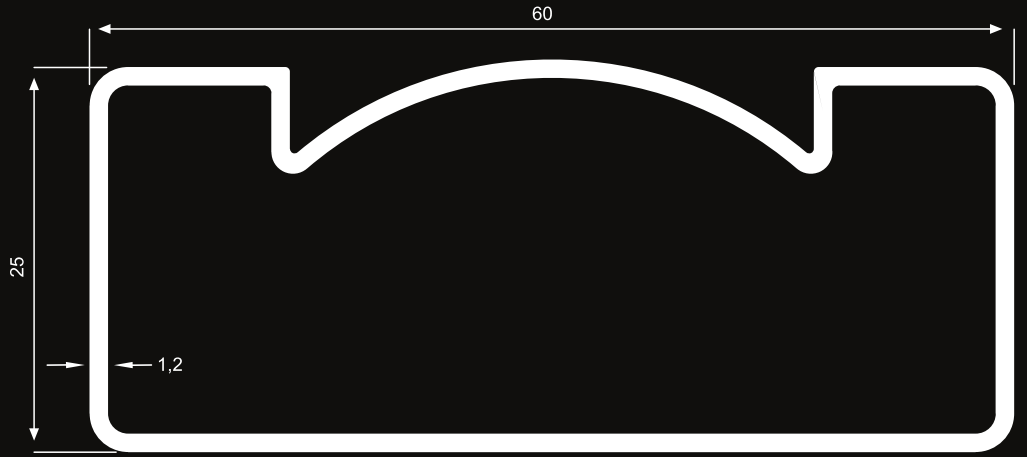

|             |  |       |
|-------------|--|-------|
| <b>2457</b> | Çevre (mm)<br><i>Perimeter</i>         | 181   |
|             | Alan (mm <sup>2</sup> )<br><i>Area</i> | 282,2 |
|             | Ağırlık (gr/m)<br><i>Weight</i>        | 764   |

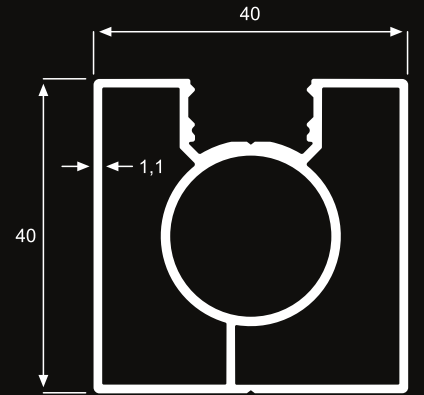





|             |                                 |      |
|-------------|---------------------------------|------|
| <b>2048</b> | Çevre (mm)<br>Perimeter         | 50.3 |
|             | Alan (mm <sup>2</sup> )<br>Area | 47.1 |
|             | Ağırlık (gr/m)<br>Weight        | 128  |

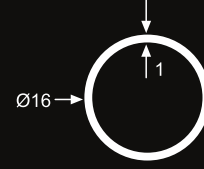

|             |                                 |       |
|-------------|---------------------------------|-------|
| <b>2047</b> | Çevre (mm)<br>Perimeter         | 110   |
|             | Alan (mm <sup>2</sup> )<br>Area | 187.7 |
|             | Ağırlık (gr/m)<br>Weight        | 509   |

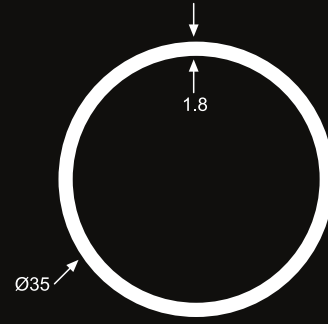

|             |                                 |       |
|-------------|---------------------------------|-------|
| <b>2440</b> | Çevre (mm)<br>Perimeter         | 110   |
|             | Alan (mm <sup>2</sup> )<br>Area | 157,9 |
|             | Ağırlık (gr/m)<br>Weight        | 428   |

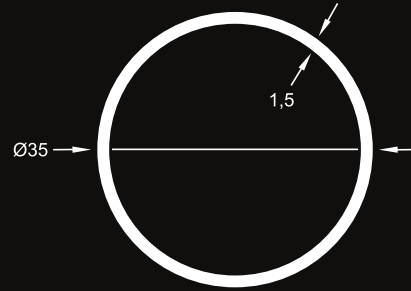

|             |                                 |       |
|-------------|---------------------------------|-------|
| <b>2046</b> | Çevre (mm)<br>Perimeter         | 157   |
|             | Alan (mm <sup>2</sup> )<br>Area | 176.5 |
|             | Ağırlık (gr/m)<br>Weight        | 478   |

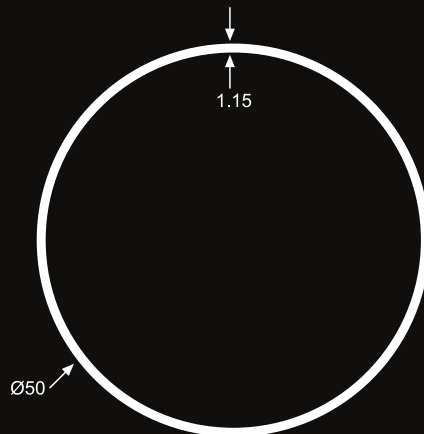



Alaşım Alüminyum

**2396**

|  |       |
|--|-------|
| Çevre (mm)<br><i>Perimeter</i>         | 157,1 |
| Alan (mm <sup>2</sup> )<br><i>Area</i> | 206,3 |
| Ağırlık (gr/m)<br><i>Weight</i>        | 559   |

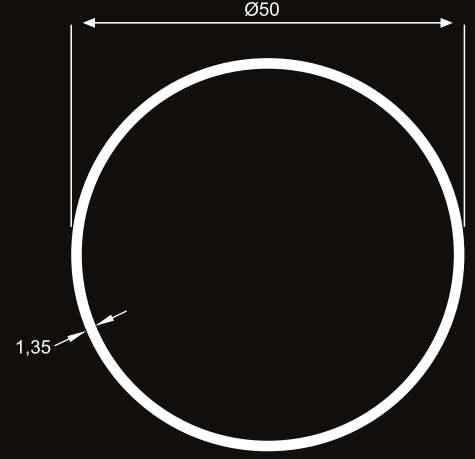

**2438**

|  |       |
|--|-------|
| Çevre (mm)<br><i>Perimeter</i>         | 157,1 |
| Alan (mm <sup>2</sup> )<br><i>Area</i> | 228,6 |
| Ağırlık (gr/m)<br><i>Weight</i>        | 620   |

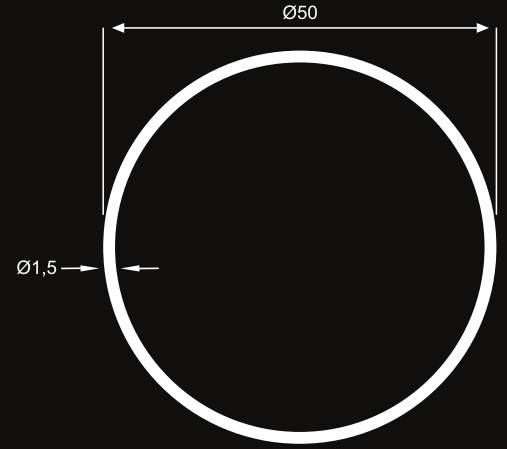

**2408**

|  |       |
|--|-------|
| Çevre (mm)<br><i>Perimeter</i>         | 157,1 |
| Alan (mm <sup>2</sup> )<br><i>Area</i> | 272,6 |
| Ağırlık (gr/m)<br><i>Weight</i>        | 738   |

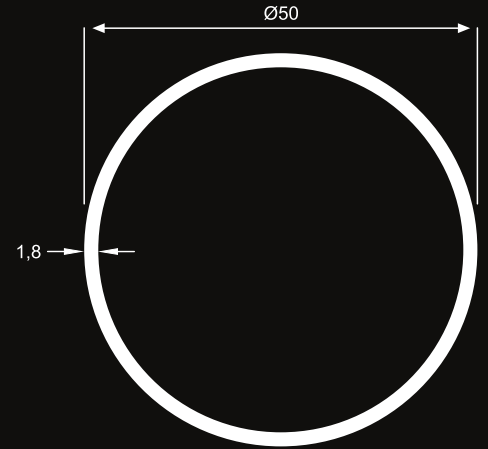



Alaşım Alüminyum

**2398**

|  |      |
|--|------|
| Çevre (mm)<br><i>Perimeter</i>         | 49,5 |
| Alan (mm <sup>2</sup> )<br><i>Area</i> | 25,5 |
| Ağırlık (gr/m)<br><i>Weight</i>        | 69   |

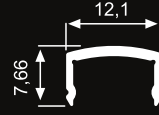

**2397**

|  |       |
|--|-------|
| Çevre (mm)<br><i>Perimeter</i>         | 140,2 |
| Alan (mm <sup>2</sup> )<br><i>Area</i> | 297,1 |
| Ağırlık (gr/m)<br><i>Weight</i>        | 805   |

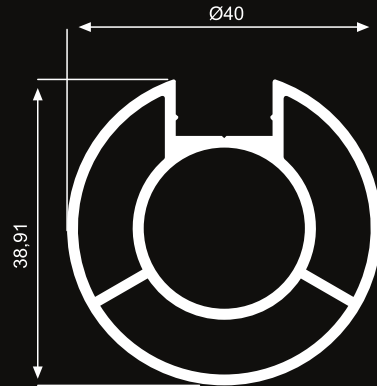

KÜPEŞTE PROFİLLERİ  
HANDRAIL PROFILES



## Alaşım Alüminyum

|             |  |      |
|-------------|--|------|
| <b>2098</b> | Çevre (mm)<br><i>Perimeter</i>         | 12.6 |
|             | Alan (mm <sup>2</sup> )<br><i>Area</i> | 12.6 |
|             | Ağırlık (gr/m)<br><i>Weight</i>        | 34   |



|             |  |      |
|-------------|--|------|
| <b>2099</b> | Çevre (mm)<br><i>Perimeter</i>         | 15.7 |
|             | Alan (mm <sup>2</sup> )<br><i>Area</i> | 19.6 |
|             | Ağırlık (gr/m)<br><i>Weight</i>        | 53   |



|             |  |      |
|-------------|--|------|
| <b>2100</b> | Çevre (mm)<br><i>Perimeter</i>         | 18.8 |
|             | Alan (mm <sup>2</sup> )<br><i>Area</i> | 28.3 |
|             | Ağırlık (gr/m)<br><i>Weight</i>        | 77   |



|             |  |      |
|-------------|--|------|
| <b>2092</b> | Çevre (mm)<br><i>Perimeter</i>         | 24.5 |
|             | Alan (mm <sup>2</sup> )<br><i>Area</i> | 47.8 |
|             | Ağırlık (gr/m)<br><i>Weight</i>        | 130  |



|             |  |      |
|-------------|--|------|
| <b>2298</b> | Çevre (mm)<br><i>Perimeter</i>         | 18.8 |
|             | Alan (mm <sup>2</sup> )<br><i>Area</i> | 15.7 |
|             | Ağırlık (gr/m)<br><i>Weight</i>        | 4.3  |



|             |  |      |
|-------------|--|------|
| <b>1762</b> | Çevre (mm)<br><i>Perimeter</i>         | 20.4 |
|             | Alan (mm <sup>2</sup> )<br><i>Area</i> | 18.6 |
|             | Ağırlık (gr/m)<br><i>Weight</i>        | 50   |

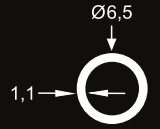

|             |  |       |
|-------------|--|-------|
| <b>2121</b> | Çevre (mm)<br><i>Perimeter</i>         | 22    |
|             | Alan (mm <sup>2</sup> )<br><i>Area</i> | 18.85 |
|             | Ağırlık (gr/m)<br><i>Weight</i>        | 51.1  |

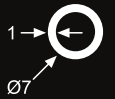

|             |  |      |
|-------------|--|------|
| <b>1913</b> | Çevre (mm)<br><i>Perimeter</i>         | 24.5 |
|             | Alan (mm <sup>2</sup> )<br><i>Area</i> | 15.6 |
|             | Ağırlık (gr/m)<br><i>Weight</i>        | 42   |





Alaşım Alüminyum

|             |  |      |
|-------------|--|------|
| <b>2096</b> | Çevre (mm)<br><i>Perimeter</i>         | 24.6 |
|             | Alan (mm <sup>2</sup> )<br><i>Area</i> | 15.7 |
|             | Ağırlık (gr/m)<br><i>Weight</i>        | 42   |



|             |  |      |
|-------------|--|------|
| <b>1814</b> | Çevre (mm)<br><i>Perimeter</i>         | 37.7 |
|             | Alan (mm <sup>2</sup> )<br><i>Area</i> | 18.9 |
|             | Ağırlık (gr/m)<br><i>Weight</i>        | 51   |



|             |  |      |
|-------------|--|------|
| <b>1857</b> | Çevre (mm)<br><i>Perimeter</i>         | 28   |
|             | Alan (mm <sup>2</sup> )<br><i>Area</i> | 27.3 |
|             | Ağırlık (gr/m)<br><i>Weight</i>        | 74   |

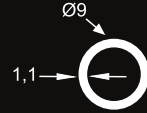

|             |  |      |
|-------------|--|------|
| <b>1761</b> | Çevre (mm)<br><i>Perimeter</i>         | 28   |
|             | Alan (mm <sup>2</sup> )<br><i>Area</i> | 27.3 |
|             | Ağırlık (gr/m)<br><i>Weight</i>        | 74   |

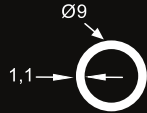

|             |  |      |
|-------------|--|------|
| <b>2170</b> | Çevre (mm)<br><i>Perimeter</i>         | 30.6 |
|             | Alan (mm <sup>2</sup> )<br><i>Area</i> | 22.5 |
|             | Ağırlık (gr/m)<br><i>Weight</i>        | 61   |



|             |  |      |
|-------------|--|------|
| <b>2094</b> | Çevre (mm)<br><i>Perimeter</i>         | 31.4 |
|             | Alan (mm <sup>2</sup> )<br><i>Area</i> | 28.3 |
|             | Ağırlık (gr/m)<br><i>Weight</i>        | 76   |



|             |  |      |
|-------------|--|------|
| <b>2335</b> | Çevre (mm)<br><i>Perimeter</i>         | 78,5 |
|             | Alan (mm <sup>2</sup> )<br><i>Area</i> | 58,9 |
|             | Ağırlık (gr/m)<br><i>Weight</i>        | 159  |

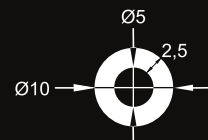

BORU PROFİLLERİ  
TUBES PROFILES



## Alaşım Alüminyum

|             |  |     |
|-------------|--|-----|
| <b>2376</b> | Çevre (mm)<br><i>Perimeter</i>         | 60  |
|             | Alan (mm <sup>2</sup> )<br><i>Area</i> | 38  |
|             | Ağırlık (gr/m)<br><i>Weight</i>        | 103 |



|             |  |      |
|-------------|--|------|
| <b>2428</b> | Çevre (mm)<br><i>Perimeter</i>         | 34,9 |
|             | Alan (mm <sup>2</sup> )<br><i>Area</i> | 31,7 |
|             | Ağırlık (gr/m)<br><i>Weight</i>        | 86   |

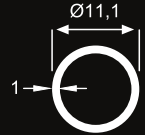

|             |  |       |
|-------------|--|-------|
| <b>2169</b> | Çevre (mm)<br><i>Perimeter</i>         | 40.8  |
|             | Alan (mm <sup>2</sup> )<br><i>Area</i> | 37.7  |
|             | Ağırlık (gr/m)<br><i>Weight</i>        | 102.2 |

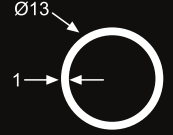

|             |  |      |
|-------------|--|------|
| <b>2095</b> | Çevre (mm)<br><i>Perimeter</i>         | 49.8 |
|             | Alan (mm <sup>2</sup> )<br><i>Area</i> | 33.6 |
|             | Ağırlık (gr/m)<br><i>Weight</i>        | 91   |

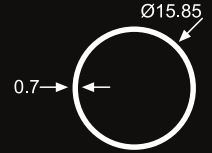

|             |  |     |
|-------------|--|-----|
| <b>2113</b> | Çevre (mm)<br><i>Perimeter</i>         | 50  |
|             | Alan (mm <sup>2</sup> )<br><i>Area</i> | 47  |
|             | Ağırlık (gr/m)<br><i>Weight</i>        | 127 |

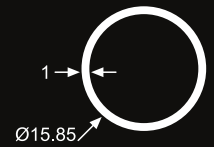

|             |  |      |
|-------------|--|------|
| <b>1912</b> | Çevre (mm)<br><i>Perimeter</i>         | 58.2 |
|             | Alan (mm <sup>2</sup> )<br><i>Area</i> | 33.6 |
|             | Ağırlık (gr/m)<br><i>Weight</i>        | -    |

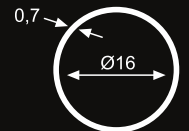

|             |  |      |
|-------------|--|------|
| <b>2048</b> | Çevre (mm)<br><i>Perimeter</i>         | 50.3 |
|             | Alan (mm <sup>2</sup> )<br><i>Area</i> | 47.1 |
|             | Ağırlık (gr/m)<br><i>Weight</i>        | 128  |

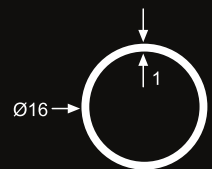



|             |  |       |
|-------------|--|-------|
| <b>2271</b> | Çevre (mm)<br><i>Perimeter</i>         | 56.5  |
|             | Alan (mm <sup>2</sup> )<br><i>Area</i> | 100.5 |
|             | Ağırlık (gr/m)<br><i>Weight</i>        | 272   |

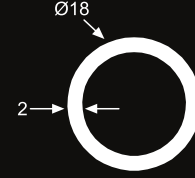

|             |  |      |
|-------------|--|------|
| <b>1822</b> | Çevre (mm)<br><i>Perimeter</i>         | 56.5 |
|             | Alan (mm <sup>2</sup> )<br><i>Area</i> | 53.4 |
|             | Ağırlık (gr/m)<br><i>Weight</i>        | 144  |

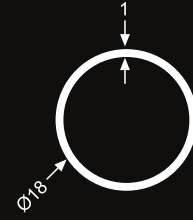

|             |  |      |
|-------------|--|------|
| <b>2179</b> | Çevre (mm)<br><i>Perimeter</i>         | 57.5 |
|             | Alan (mm <sup>2</sup> )<br><i>Area</i> | 49.2 |
|             | Ağırlık (gr/m)<br><i>Weight</i>        | 133  |

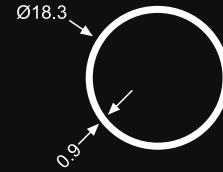

|             |  |      |
|-------------|--|------|
| <b>2343</b> | Çevre (mm)<br><i>Perimeter</i>         | 60   |
|             | Alan (mm <sup>2</sup> )<br><i>Area</i> | 45,7 |
|             | Ağırlık (gr/m)<br><i>Weight</i>        | 123  |

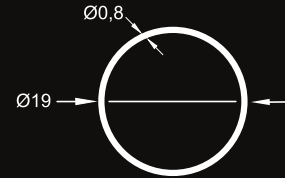

|             |  |      |
|-------------|--|------|
| <b>2180</b> | Çevre (mm)<br><i>Perimeter</i>         | 63.7 |
|             | Alan (mm <sup>2</sup> )<br><i>Area</i> | 54.8 |
|             | Ağırlık (gr/m)<br><i>Weight</i>        | 149  |

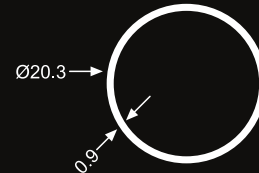

|             |  |      |
|-------------|--|------|
| <b>2106</b> | Çevre (mm)<br><i>Perimeter</i>         | 66.9 |
|             | Alan (mm <sup>2</sup> )<br><i>Area</i> | 57.6 |
|             | Ağırlık (gr/m)<br><i>Weight</i>        | 156  |





Alaşım Alüminyum

|             |  |       |
|-------------|--|-------|
| <b>2161</b> | Çevre (mm)<br><i>Perimeter</i>         | 67.9  |
|             | Alan (mm <sup>2</sup> )<br><i>Area</i> | 58.5  |
|             | Ağırlık (gr/m)<br><i>Weight</i>        | 158.5 |

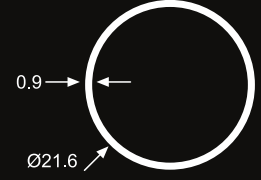

|             |  |      |
|-------------|--|------|
| <b>1901</b> | Çevre (mm)<br><i>Perimeter</i>         | 69.1 |
|             | Alan (mm <sup>2</sup> )<br><i>Area</i> | 53.2 |
|             | Ağırlık (gr/m)<br><i>Weight</i>        | 144  |

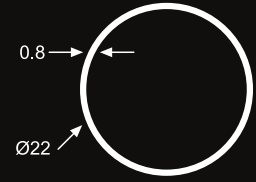

|             |  |      |
|-------------|--|------|
| <b>1903</b> | Çevre (mm)<br><i>Perimeter</i>         | 69.1 |
|             | Alan (mm <sup>2</sup> )<br><i>Area</i> | 59.6 |
|             | Ağırlık (gr/m)<br><i>Weight</i>        | 162  |

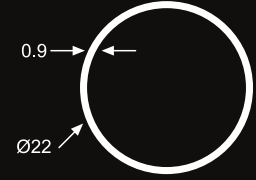

|             |  |     |
|-------------|--|-----|
| <b>2407</b> | Çevre (mm)<br><i>Perimeter</i>         | -   |
|             | Alan (mm <sup>2</sup> )<br><i>Area</i> | -   |
|             | Ağırlık (gr/m)<br><i>Weight</i>        | 128 |

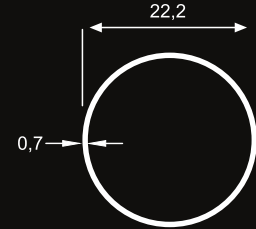

|             |  |      |
|-------------|--|------|
| <b>2178</b> | Çevre (mm)<br><i>Perimeter</i>         | 71.6 |
|             | Alan (mm <sup>2</sup> )<br><i>Area</i> | 55.3 |
|             | Ağırlık (gr/m)<br><i>Weight</i>        | 150  |

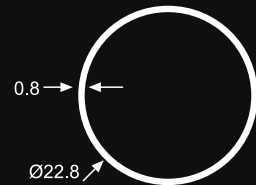

|             |  |      |
|-------------|--|------|
| <b>1899</b> | Çevre (mm)<br><i>Perimeter</i>         | 72.8 |
|             | Alan (mm <sup>2</sup> )<br><i>Area</i> | 63   |
|             | Ağırlık (gr/m)<br><i>Weight</i>        | 170  |

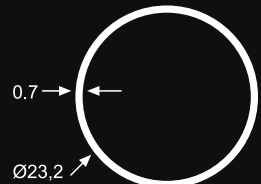





|             |  |       |
|-------------|--|-------|
| <b>1902</b> | Çevre (mm)<br><i>Perimeter</i>         | 75.4  |
|             | Alan (mm <sup>2</sup> )<br><i>Area</i> | 138.2 |
|             | Ağırlık (gr/m)<br><i>Weight</i>        | 374   |

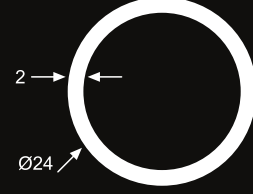

|             |  |       |
|-------------|--|-------|
| <b>2474</b> | Çevre (mm)<br><i>Perimeter</i>         | 77,9  |
|             | Alan (mm <sup>2</sup> )<br><i>Area</i> | 175,1 |
|             | Ağırlık (gr/m)<br><i>Weight</i>        | 474   |

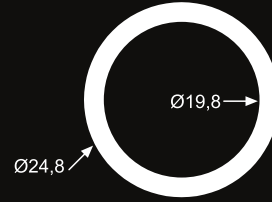

|             |  |      |
|-------------|--|------|
| <b>1905</b> | Çevre (mm)<br><i>Perimeter</i>         | 78.5 |
|             | Alan (mm <sup>2</sup> )<br><i>Area</i> | 60.8 |
|             | Ağırlık (gr/m)<br><i>Weight</i>        | 165  |

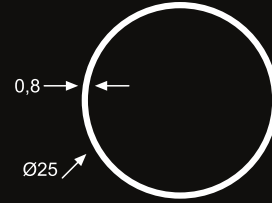

|             |  |       |
|-------------|--|-------|
| <b>2168</b> | Çevre (mm)<br><i>Perimeter</i>         | 78.5  |
|             | Alan (mm <sup>2</sup> )<br><i>Area</i> | 110.7 |
|             | Ağırlık (gr/m)<br><i>Weight</i>        | 300   |

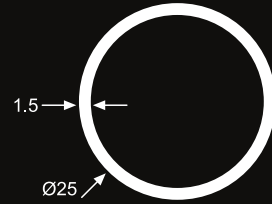

|             |  |       |
|-------------|--|-------|
| <b>2475</b> | Çevre (mm)<br><i>Perimeter</i>         | 91,1  |
|             | Alan (mm <sup>2</sup> )<br><i>Area</i> | 169,6 |
|             | Ağırlık (gr/m)<br><i>Weight</i>        | 460   |

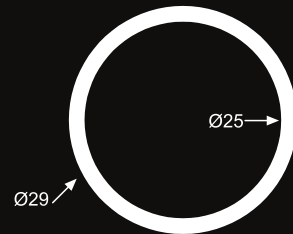

|             |  |      |
|-------------|--|------|
| <b>1911</b> | Çevre (mm)<br><i>Perimeter</i>         | 81.6 |
|             | Alan (mm <sup>2</sup> )<br><i>Area</i> | 70.9 |
|             | Ağırlık (gr/m)<br><i>Weight</i>        | 192  |

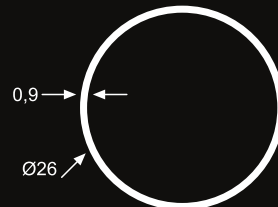



Alaşım Alüminyum

|             |  |       |
|-------------|--|-------|
| <b>2440</b> | Çevre (mm)<br><i>Perimeter</i>         | 110   |
|             | Alan (mm <sup>2</sup> )<br><i>Area</i> | 157,9 |
|             | Ağırlık (gr/m)<br><i>Weight</i>        | 428   |

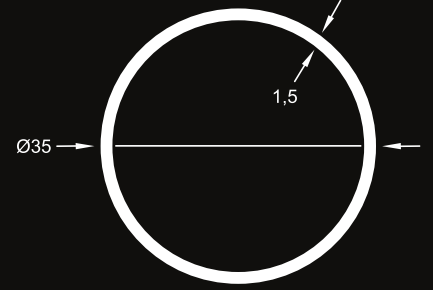

|             |  |       |
|-------------|--|-------|
| <b>2047</b> | Çevre (mm)<br><i>Perimeter</i>         | 110   |
|             | Alan (mm <sup>2</sup> )<br><i>Area</i> | 187.7 |
|             | Ağırlık (gr/m)<br><i>Weight</i>        | 509   |

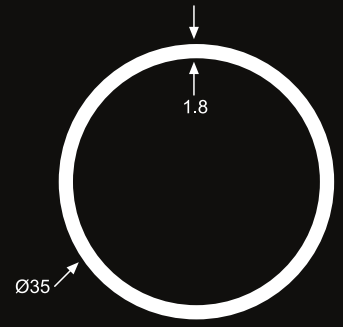

|             |  |       |
|-------------|--|-------|
| <b>2046</b> | Çevre (mm)<br><i>Perimeter</i>         | 157   |
|             | Alan (mm <sup>2</sup> )<br><i>Area</i> | 176.5 |
|             | Ağırlık (gr/m)<br><i>Weight</i>        | 478   |

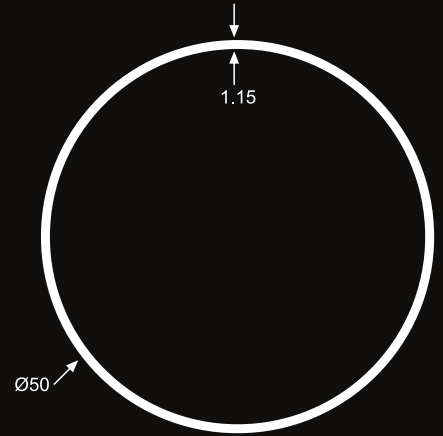

|             |  |       |
|-------------|--|-------|
| <b>2396</b> | Çevre (mm)<br><i>Perimeter</i>         | 157,1 |
|             | Alan (mm <sup>2</sup> )<br><i>Area</i> | 206,3 |
|             | Ağırlık (gr/m)<br><i>Weight</i>        | 559   |

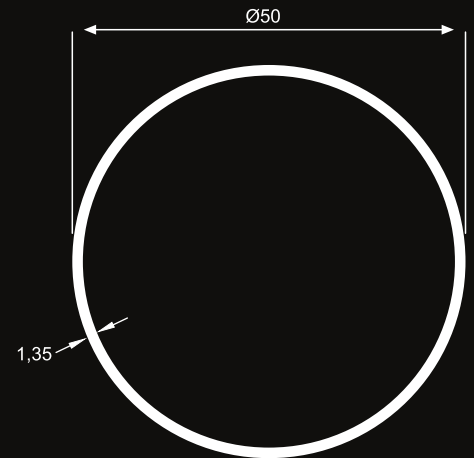



Alaşım Alüminyum

**2438**

|  |       |
|--|-------|
| Çevre (mm)<br><i>Perimeter</i>         | 157.1 |
| Alan (mm <sup>2</sup> )<br><i>Area</i> | 228.6 |
| Ağırlık (gr/m)<br><i>Weight</i>        | 620   |

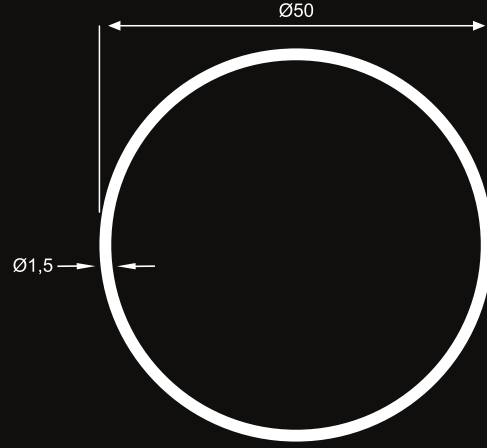

**2408**

|  |       |
|--|-------|
| Çevre (mm)<br><i>Perimeter</i>         | 157,1 |
| Alan (mm <sup>2</sup> )<br><i>Area</i> | 272,6 |
| Ağırlık (gr/m)<br><i>Weight</i>        | 738   |

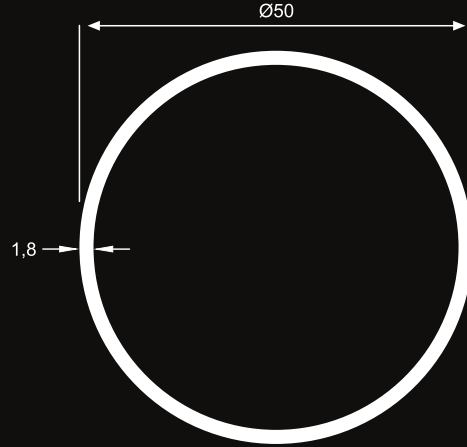

**2176**

|  |       |
|--|-------|
| Çevre (mm)<br><i>Perimeter</i>         | 188.5 |
| Alan (mm <sup>2</sup> )<br><i>Area</i> | 275.7 |
| Ağırlık (gr/m)<br><i>Weight</i>        | 747   |

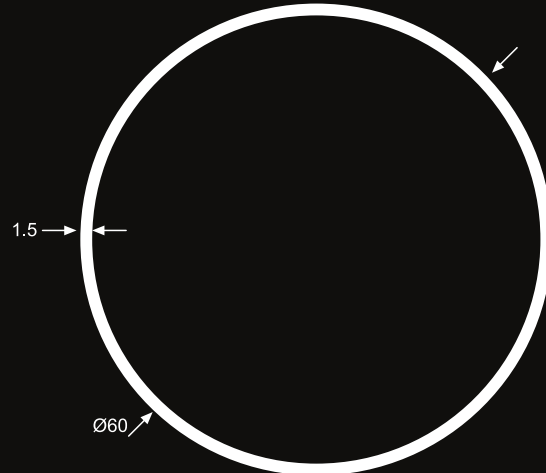

BORU PROFİLLERİ  
TUBES PROFILES



Alaşım Alüminyum

**2028**

|  |       |
|--|-------|
| Çevre (mm)<br><i>Perimeter</i>         | 188,5 |
| Alan (mm <sup>2</sup> )<br><i>Area</i> | 364,5 |
| Ağırlık (gr/m)<br><i>Weight</i>        | 987   |

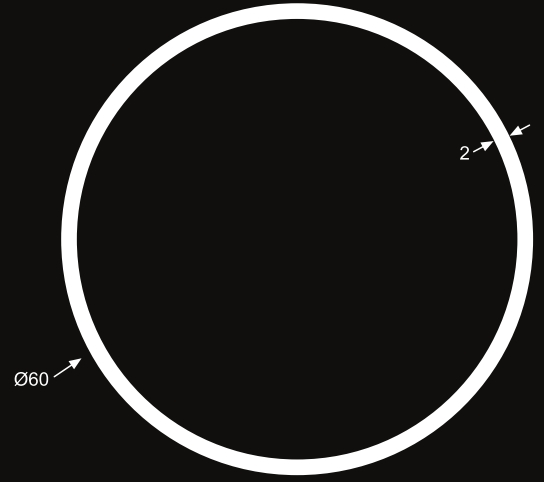

**2421**

|  |       |
|--|-------|
| Çevre (mm)<br><i>Perimeter</i>         | 251,3 |
| Alan (mm <sup>2</sup> )<br><i>Area</i> | 609   |
| Ağırlık (gr/m)<br><i>Weight</i>        | 1650  |

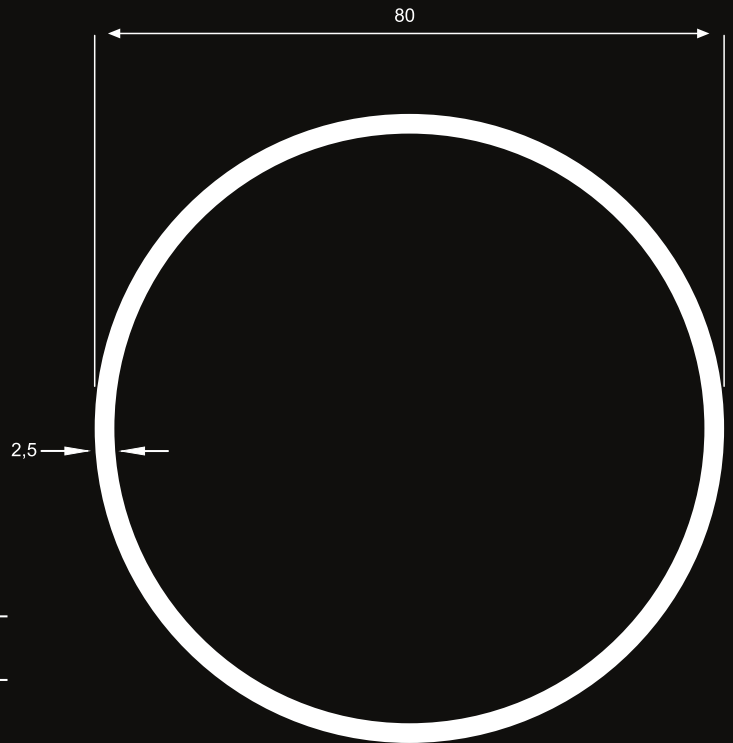



Alaşım Alüminyum

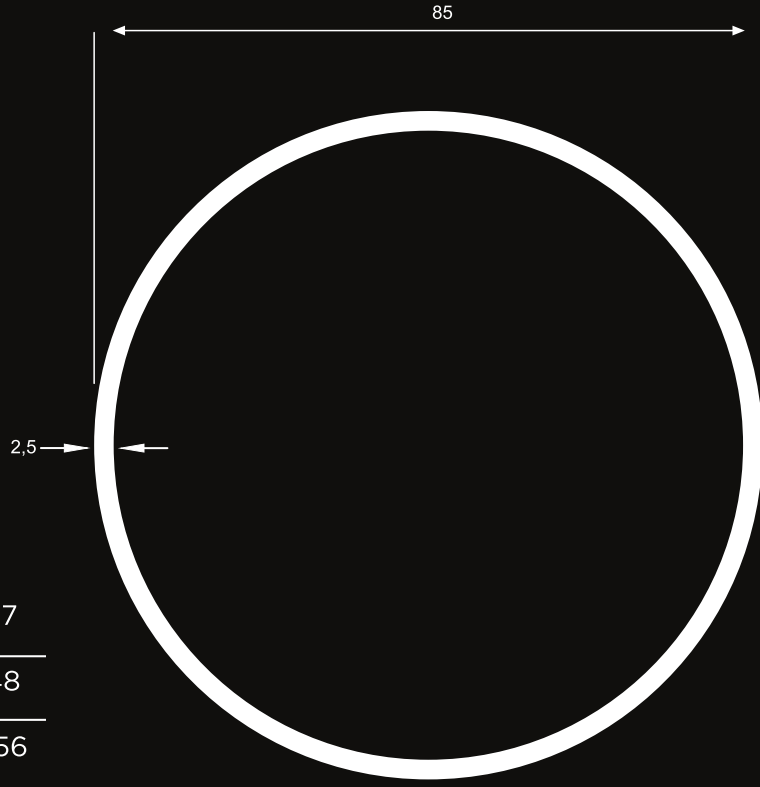

**2420**

Çevre (mm)  
Perimeter

267

Alan (mm<sup>2</sup>)  
Area

648

Ağırlık (gr/m)  
Weight

1756

BORU PROFİLLERİ  
TUBES PROFILES



Alaşım Alüminyum

|             |  |     |
|-------------|--|-----|
| <b>2031</b> | Çevre (mm)<br><i>Perimeter</i>         | 65  |
|             | Alan (mm <sup>2</sup> )<br><i>Area</i> | 44  |
|             | Ağırlık (gr/m)<br><i>Weight</i>        | 119 |

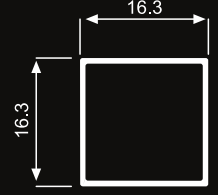

|             |  |      |
|-------------|--|------|
| <b>2456</b> | Çevre (mm)<br><i>Perimeter</i>         | 39,6 |
|             | Alan (mm <sup>2</sup> )<br><i>Area</i> | 41,7 |
|             | Ağırlık (gr/m)<br><i>Weight</i>        | 113  |

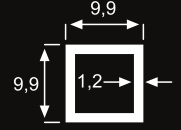

|             |  |     |
|-------------|--|-----|
| <b>2336</b> | Çevre (mm)<br><i>Perimeter</i>         | 80  |
|             | Alan (mm <sup>2</sup> )<br><i>Area</i> | 111 |
|             | Ağırlık (gr/m)<br><i>Weight</i>        | 300 |

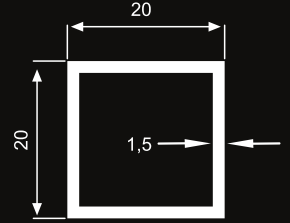

|             |  |     |
|-------------|--|-----|
| <b>1756</b> | Çevre (mm)<br><i>Perimeter</i>         | 118 |
|             | Alan (mm <sup>2</sup> )<br><i>Area</i> | 103 |
|             | Ağırlık (gr/m)<br><i>Weight</i>        | 279 |

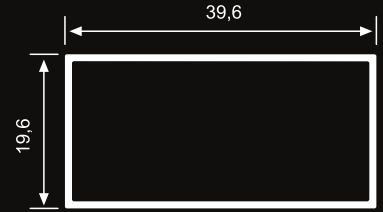

|             |  |       |
|-------------|--|-------|
| <b>2463</b> | Çevre (mm)<br><i>Perimeter</i>         | 116,5 |
|             | Alan (mm <sup>2</sup> )<br><i>Area</i> | 167,8 |
|             | Ağırlık (gr/m)<br><i>Weight</i>        | 455   |

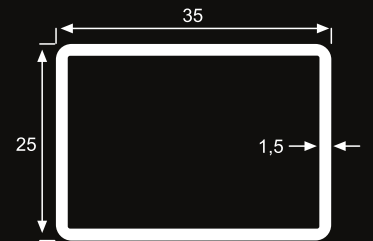



Alaşım Alüminyum

**2059**

|  |       |
|--|-------|
| Çevre (mm)<br><i>Perimeter</i>         | 140   |
| Alan (mm <sup>2</sup> )<br><i>Area</i> | 162.2 |
| Ağırlık (gr/m)<br><i>Weight</i>        | 440   |

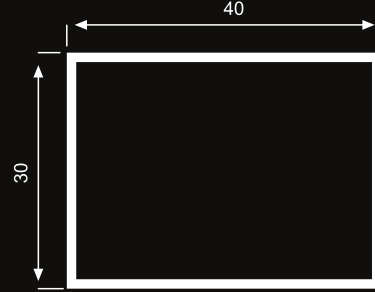

**2360**

|  |       |
|--|-------|
| Çevre (mm)<br><i>Perimeter</i>         | 196,3 |
| Alan (mm <sup>2</sup> )<br><i>Area</i> | 537,7 |
| Ağırlık (gr/m)<br><i>Weight</i>        | 1457  |

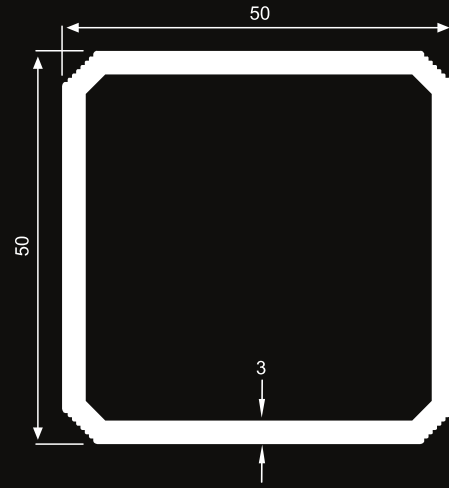

**2337**

|  |       |
|--|-------|
| Çevre (mm)<br><i>Perimeter</i>         | 218,8 |
| Alan (mm <sup>2</sup> )<br><i>Area</i> | 419   |
| Ağırlık (gr/m)<br><i>Weight</i>        | 1135  |

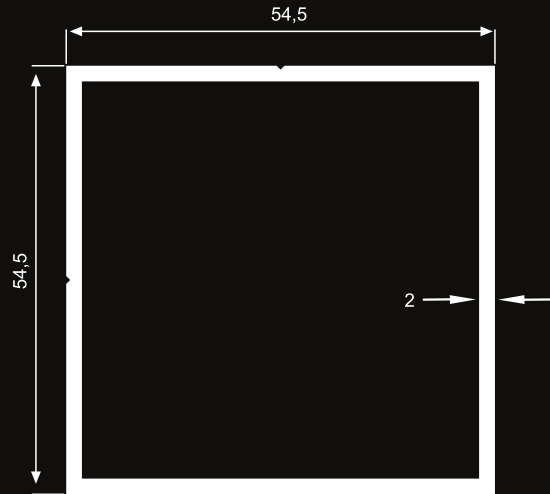

**2057**

|  |       |
|--|-------|
| Çevre (mm)<br><i>Perimeter</i>         | 158.2 |
| Alan (mm <sup>2</sup> )<br><i>Area</i> | 230.1 |
| Ağırlık (gr/m)<br><i>Weight</i>        | 624   |



KUTU VE MASTAR PROFİLLERİ  
BOX PROFILES



Alaşım Alüminyum

**1789**

|  |     |
|--|-----|
| Çevre (mm)<br><i>Perimeter</i>         | 179 |
| Alan (mm <sup>2</sup> )<br><i>Area</i> | 124 |
| Ağırlık (gr/m)<br><i>Weight</i>        | 336 |

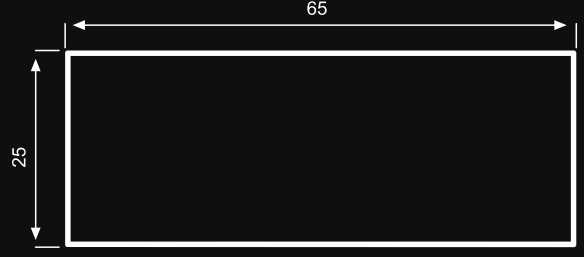

**1856**

|  |     |
|--|-----|
| Çevre (mm)<br><i>Perimeter</i>         | 199 |
| Alan (mm <sup>2</sup> )<br><i>Area</i> | 147 |
| Ağırlık (gr/m)<br><i>Weight</i>        | 398 |

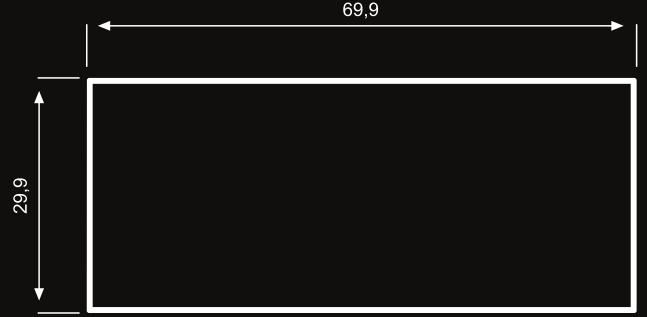

**2103**

|  |       |
|--|-------|
| Çevre (mm)<br><i>Perimeter</i>         | 215.5 |
| Alan (mm <sup>2</sup> )<br><i>Area</i> | 415.6 |
| Ağırlık (gr/m)<br><i>Weight</i>        | 1126  |

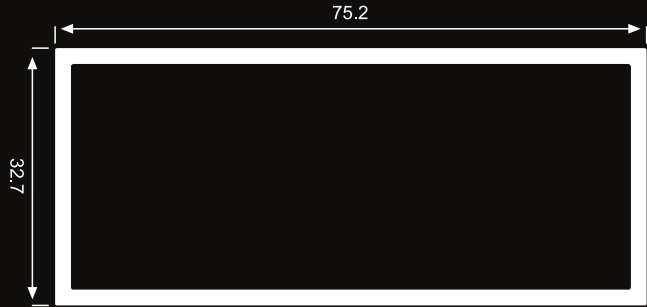

**2058**

|  |       |
|--|-------|
| Çevre (mm)<br><i>Perimeter</i>         | 212.3 |
| Alan (mm <sup>2</sup> )<br><i>Area</i> | 250.1 |
| Ağırlık (gr/m)<br><i>Weight</i>        | 678   |

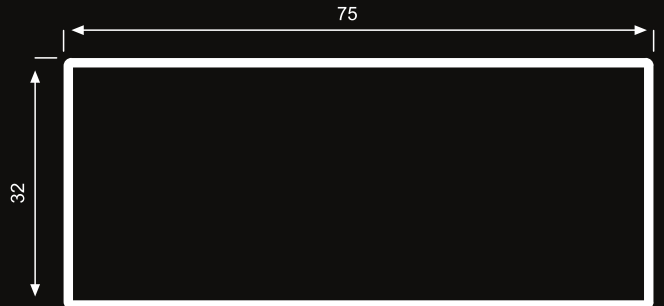





Alaşım Alüminyum

**1790**

|  |       |
|--|-------|
| Çevre (mm)<br><i>Perimeter</i>         | 300   |
| Alan (mm <sup>2</sup> )<br><i>Area</i> | 498.4 |
| Ağırlık (gr/m)<br><i>Weight</i>        | 1350  |



**2063**

|  |      |
|--|------|
| Çevre (mm)<br><i>Perimeter</i>         | 283  |
| Alan (mm <sup>2</sup> )<br><i>Area</i> | 500  |
| Ağırlık (gr/m)<br><i>Weight</i>        | 1355 |



**1857-M**

|  |     |
|--|-----|
| Çevre (mm)<br><i>Perimeter</i>         | 197 |
| Alan (mm <sup>2</sup> )<br><i>Area</i> | 156 |
| Ağırlık (gr/m)<br><i>Weight</i>        | 423 |

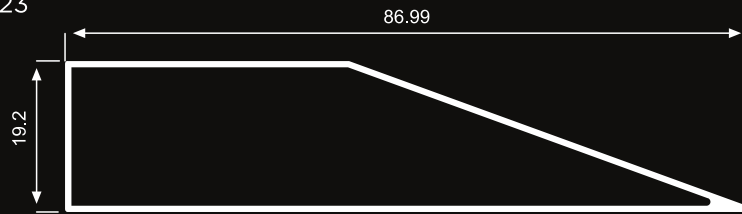



Alaşım Alüminyum

|             |  |      |
|-------------|--|------|
| <b>1826</b> | Çevre (mm)<br><i>Perimeter</i>         | 80.4 |
|             | Alan (mm <sup>2</sup> )<br><i>Area</i> | 32.6 |
|             | Ağırlık (gr/m)<br><i>Weight</i>        | 88   |

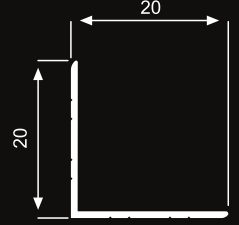

|             |  |       |
|-------------|--|-------|
| <b>1827</b> | Çevre (mm)<br><i>Perimeter</i>         | 121.1 |
|             | Alan (mm <sup>2</sup> )<br><i>Area</i> | 46.6  |
|             | Ağırlık (gr/m)<br><i>Weight</i>        | 126   |

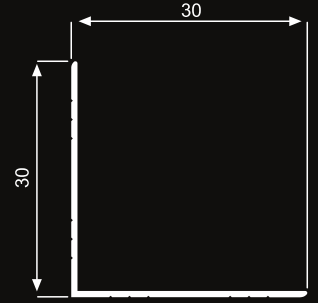

|             |  |       |
|-------------|--|-------|
| <b>2208</b> | Çevre (mm)<br><i>Perimeter</i>         | 169.2 |
|             | Alan (mm <sup>2</sup> )<br><i>Area</i> | 145.3 |
|             | Ağırlık (gr/m)<br><i>Weight</i>        | 394   |

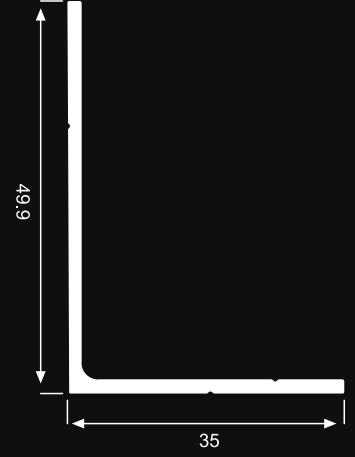

|             |  |       |
|-------------|--|-------|
| <b>2245</b> | Çevre (mm)<br><i>Perimeter</i>         | 451.1 |
|             | Alan (mm <sup>2</sup> )<br><i>Area</i> | 412.2 |
|             | Ağırlık (gr/m)<br><i>Weight</i>        | 1117  |

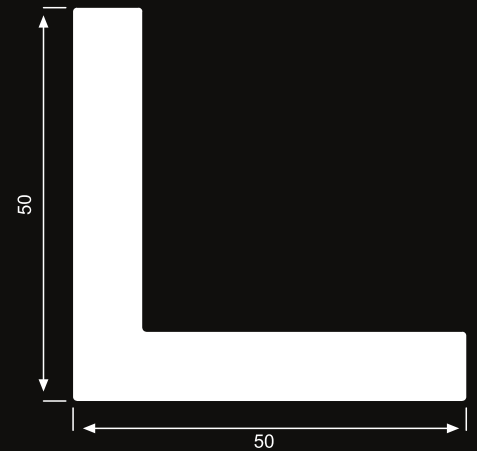



Alaşım Alüminyum

**2419**

|  |      |
|--|------|
| Çevre (mm)<br><i>Perimeter</i>         | 240  |
| Alan (mm <sup>2</sup> )<br><i>Area</i> | 684  |
| Ağırlık (gr/m)<br><i>Weight</i>        | 1854 |

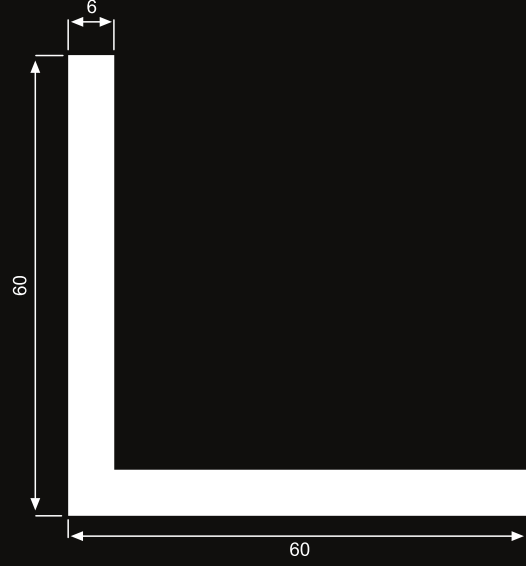

**2272**

|  |     |
|--|-----|
| Çevre (mm)<br><i>Perimeter</i>         | 240 |
| Alan (mm <sup>2</sup> )<br><i>Area</i> | 351 |
| Ağırlık (gr/m)<br><i>Weight</i>        | 951 |

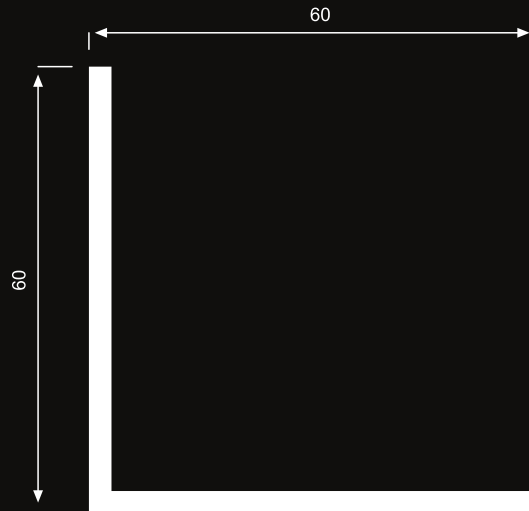

L PROFİLLERİ  
L PROFILES



Alaşım Alüminyum

|             |  |       |
|-------------|--|-------|
| <b>2231</b> | Çevre (mm)<br><i>Perimeter</i>         | 265.8 |
|             | Alan (mm <sup>2</sup> )<br><i>Area</i> | 625.1 |
|             | Ağırlık (gr/m)<br><i>Weight</i>        | 1694  |

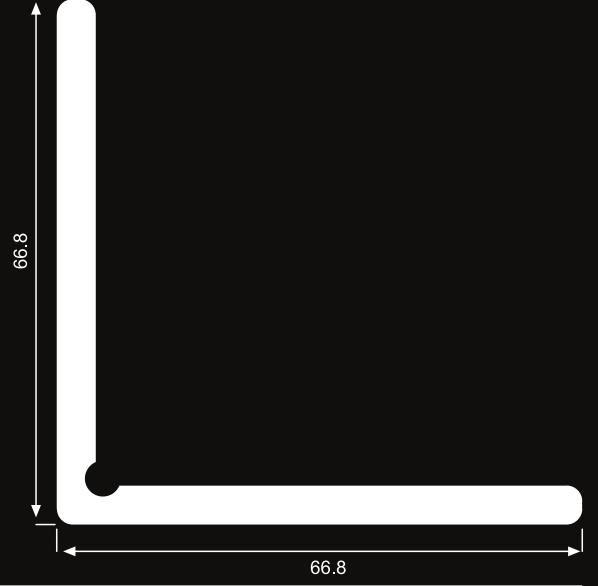

|             |  |      |
|-------------|--|------|
| <b>2418</b> | Çevre (mm)<br><i>Perimeter</i>         | 320  |
|             | Alan (mm <sup>2</sup> )<br><i>Area</i> | 924  |
|             | Ağırlık (gr/m)<br><i>Weight</i>        | 2504 |

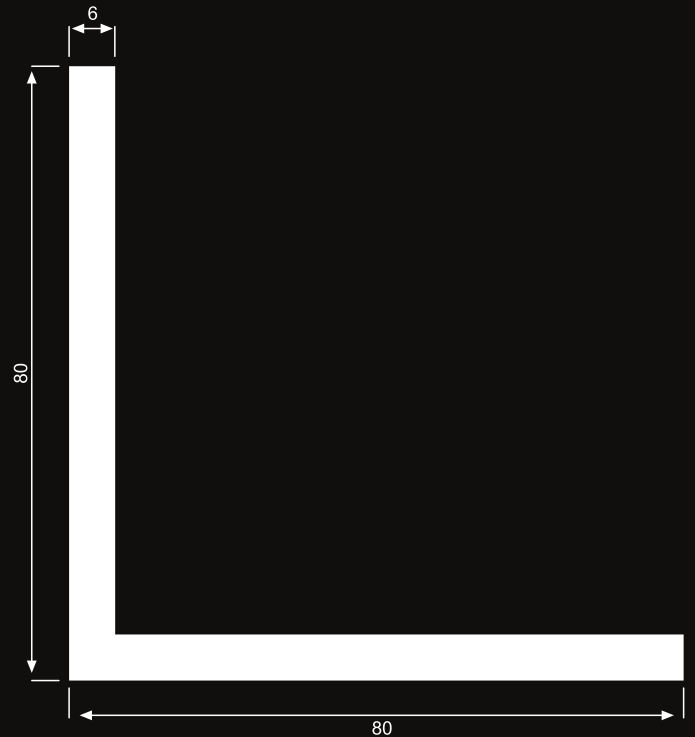



|             |  |      |
|-------------|--|------|
| <b>2375</b> | Çevre (mm)<br><i>Perimeter</i>         | 43,7 |
|             | Alan (mm <sup>2</sup> )<br><i>Area</i> | 17   |
|             | Ağırlık (gr/m)<br><i>Weight</i>        | 46   |

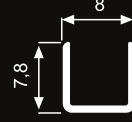

|             |  |    |
|-------------|--|----|
| <b>2276</b> | Çevre (mm)<br><i>Perimeter</i>         | 58 |
|             | Alan (mm <sup>2</sup> )<br><i>Area</i> | 28 |
|             | Ağırlık (gr/m)<br><i>Weight</i>        | 76 |

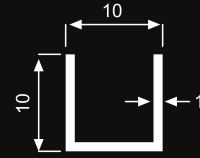

|             |  |       |
|-------------|--|-------|
| <b>2273</b> | Çevre (mm)<br><i>Perimeter</i>         | 75.6  |
|             | Alan (mm <sup>2</sup> )<br><i>Area</i> | 43.92 |
|             | Ağırlık (gr/m)<br><i>Weight</i>        | 119   |

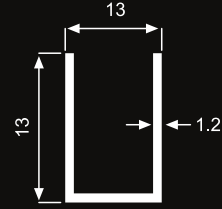

|             |  |       |
|-------------|--|-------|
| <b>2274</b> | Çevre (mm)<br><i>Perimeter</i>         | 103.6 |
|             | Alan (mm <sup>2</sup> )<br><i>Area</i> | 60.72 |
|             | Ağırlık (gr/m)<br><i>Weight</i>        | 164   |

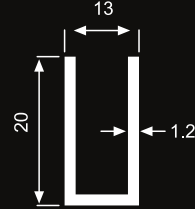

|             |  |      |
|-------------|--|------|
| <b>2275</b> | Çevre (mm)<br><i>Perimeter</i>         | 97   |
|             | Alan (mm <sup>2</sup> )<br><i>Area</i> | 70.5 |
|             | Ağırlık (gr/m)<br><i>Weight</i>        | 191  |

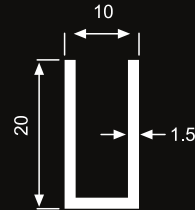

|             |  |      |
|-------------|--|------|
| <b>2323</b> | Çevre (mm)<br><i>Perimeter</i>         | 76,6 |
|             | Alan (mm <sup>2</sup> )<br><i>Area</i> | 35,7 |
|             | Ağırlık (gr/m)<br><i>Weight</i>        | 97   |

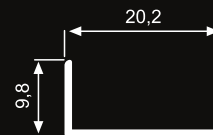



Alaşım Alüminyum

|             |  |     |
|-------------|--|-----|
| <b>2222</b> | Çevre (mm)<br><i>Perimeter</i>         | 202 |
|             | Alan (mm <sup>2</sup> )<br><i>Area</i> | 282 |
|             | Ağırlık (gr/m)<br><i>Weight</i>        | 764 |

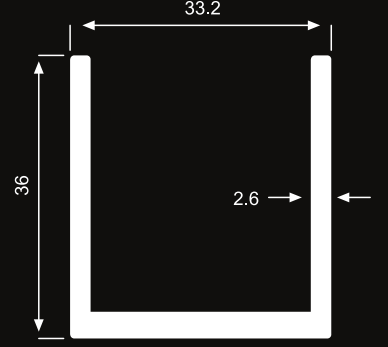

|             |  |       |
|-------------|--|-------|
| <b>2260</b> | Çevre (mm)<br><i>Perimeter</i>         | 305.4 |
|             | Alan (mm <sup>2</sup> )<br><i>Area</i> | 204.5 |
|             | Ağırlık (gr/m)<br><i>Weight</i>        | 554   |



|             |  |       |
|-------------|--|-------|
| <b>2261</b> | Çevre (mm)<br><i>Perimeter</i>         | 425.4 |
|             | Alan (mm <sup>2</sup> )<br><i>Area</i> | 279.5 |
|             | Ağırlık (gr/m)<br><i>Weight</i>        | 757   |

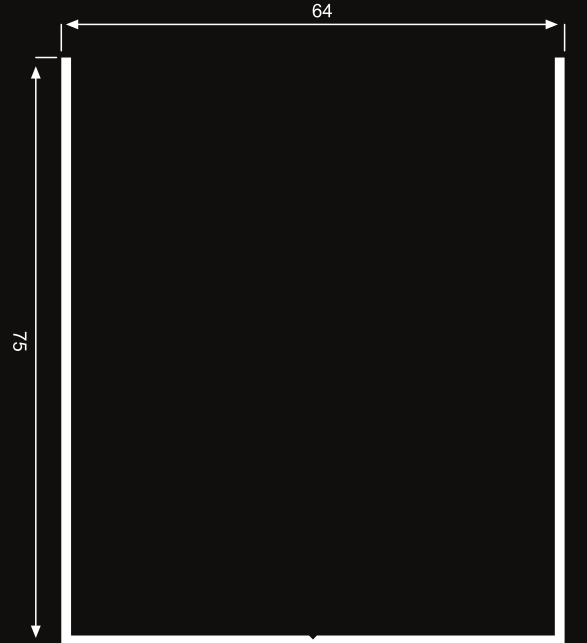



Alaşım Alüminyum

**2295**

Çevre (mm)  
Perimeter

63,5

Alan (mm<sup>2</sup>)  
Area

60

Ağırlık (gr/m)  
Weight

162



**2328**

Çevre (mm)  
Perimeter

66

Alan (mm<sup>2</sup>)  
Area

90

Ağırlık (gr/m)  
Weight

244

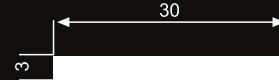

**2357**

Çevre (mm)  
Perimeter

75,5

Alan (mm<sup>2</sup>)  
Area

239,9

Ağırlık (gr/m)  
Weight

650

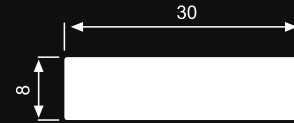

**2359**

Çevre (mm)  
Perimeter

82,5

Alan (mm<sup>2</sup>)  
Area

59,9

Ağırlık (gr/m)  
Weight

162



LAMA PROFİLLERİ  
FLAT BAR PROFILES



Alaşım Alüminyum

|             |  |      |
|-------------|--|------|
| <b>1764</b> | Çevre (mm)<br><i>Perimeter</i>         | 71.6 |
|             | Alan (mm <sup>2</sup> )<br><i>Area</i> | 48.6 |
|             | Ağırlık (gr/m)<br><i>Weight</i>        | 132  |

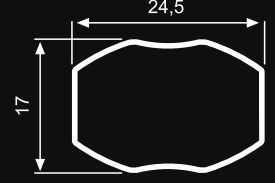

|             |  |      |
|-------------|--|------|
| <b>1765</b> | Çevre (mm)<br><i>Perimeter</i>         | 58.8 |
|             | Alan (mm <sup>2</sup> )<br><i>Area</i> | 39.7 |
|             | Ağırlık (gr/m)<br><i>Weight</i>        | 108  |

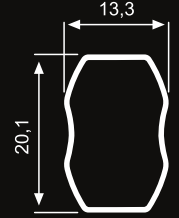

|             |  |       |
|-------------|--|-------|
| <b>1817</b> | Çevre (mm)<br><i>Perimeter</i>         | 118.2 |
|             | Alan (mm <sup>2</sup> )<br><i>Area</i> | 70.8  |
|             | Ağırlık (gr/m)<br><i>Weight</i>        | 192   |

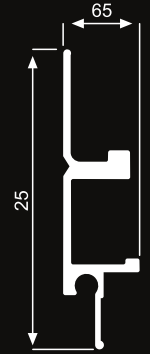

|             |  |      |
|-------------|--|------|
| <b>1841</b> | Çevre (mm)<br><i>Perimeter</i>         | 88.9 |
|             | Alan (mm <sup>2</sup> )<br><i>Area</i> | 45.3 |
|             | Ağırlık (gr/m)<br><i>Weight</i>        | 123  |







Alaşım Alüminyum

**1847**

|                                 |     |
|---------------------------------|-----|
| Çevre (mm)<br>Perimeter         | 165 |
| Alan (mm <sup>2</sup> )<br>Area | 110 |
| Ağırlık (gr/m)<br>Weight        | 298 |

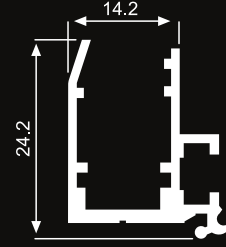

**1907**

|                                 |      |
|---------------------------------|------|
| Çevre (mm)<br>Perimeter         | 51.4 |
| Alan (mm <sup>2</sup> )<br>Area | 43.7 |
| Ağırlık (gr/m)<br>Weight        | 118  |

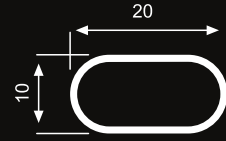

**1896**

|                                 |     |
|---------------------------------|-----|
| Çevre (mm)<br>Perimeter         | 189 |
| Alan (mm <sup>2</sup> )<br>Area | 156 |
| Ağırlık (gr/m)<br>Weight        | 423 |

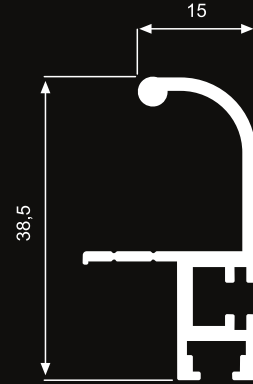

**1897**

|                                 |      |
|---------------------------------|------|
| Çevre (mm)<br>Perimeter         | 93.4 |
| Alan (mm <sup>2</sup> )<br>Area | 95.6 |
| Ağırlık (gr/m)<br>Weight        | 259  |

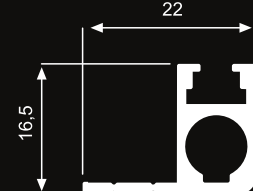

**1898**

|                                 |       |
|---------------------------------|-------|
| Çevre (mm)<br>Perimeter         | 328.7 |
| Alan (mm <sup>2</sup> )<br>Area | 247   |
| Ağırlık (gr/m)<br>Weight        | 669   |

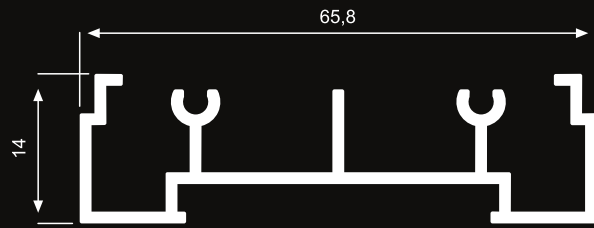

ÖZEL PROFİLLER  
SPECIAL PROFILES



Alaşım Alüminyum

|             |                                 |       |
|-------------|---------------------------------|-------|
| <b>1895</b> | Çevre (mm)<br>Perimeter         | 313.8 |
|             | Alan (mm <sup>2</sup> )<br>Area | 326.2 |
|             | Ağırlık (gr/m)<br>Weight        | 884   |

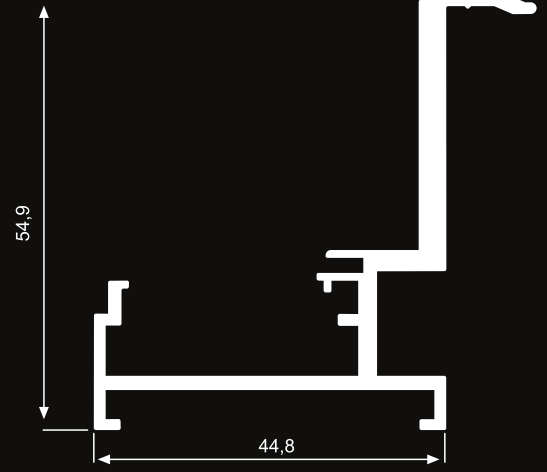

|             |                                 |      |
|-------------|---------------------------------|------|
| <b>1908</b> | Çevre (mm)<br>Perimeter         | 81.7 |
|             | Alan (mm <sup>2</sup> )<br>Area | 48.1 |
|             | Ağırlık (gr/m)<br>Weight        | 130  |

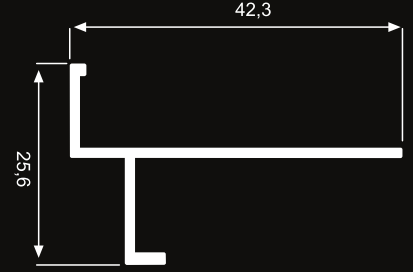

|             |                                 |      |
|-------------|---------------------------------|------|
| <b>2060</b> | Çevre (mm)<br>Perimeter         | 95.8 |
|             | Alan (mm <sup>2</sup> )<br>Area | 92.6 |
|             | Ağırlık (gr/m)<br>Weight        | 250  |

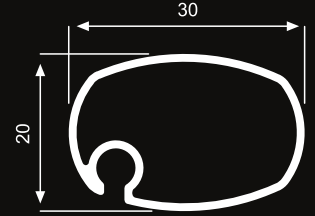

|             |                                 |      |
|-------------|---------------------------------|------|
| <b>2061</b> | Çevre (mm)<br>Perimeter         | 79   |
|             | Alan (mm <sup>2</sup> )<br>Area | 90.3 |
|             | Ağırlık (gr/m)<br>Weight        | 244  |

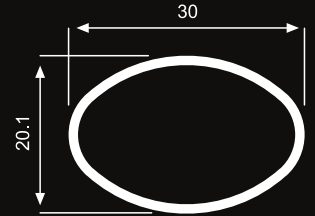

|             |                                 |       |
|-------------|---------------------------------|-------|
| <b>2062</b> | Çevre (mm)<br>Perimeter         | 96.7  |
|             | Alan (mm <sup>2</sup> )<br>Area | 102.6 |
|             | Ağırlık (gr/m)<br>Weight        | 278   |

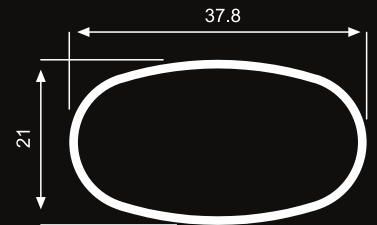



Alaşım Alüminyum

**2064**

|                                 |     |
|---------------------------------|-----|
| Çevre (mm)<br>Perimeter         | 89  |
| Alan (mm <sup>2</sup> )<br>Area | 111 |
| Ağırlık (gr/m)<br>Weight        | 301 |

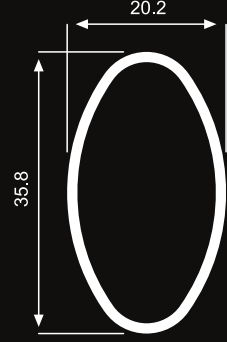

**2065**

|                                 |     |
|---------------------------------|-----|
| Çevre (mm)<br>Perimeter         | 86  |
| Alan (mm <sup>2</sup> )<br>Area | 106 |
| Ağırlık (gr/m)<br>Weight        | 287 |

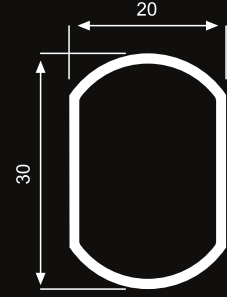

**2066**

|                                 |     |
|---------------------------------|-----|
| Çevre (mm)<br>Perimeter         | 46  |
| Alan (mm <sup>2</sup> )<br>Area | 38  |
| Ağırlık (gr/m)<br>Weight        | 103 |

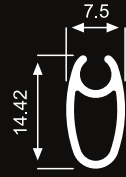

**2067**

|                                 |     |
|---------------------------------|-----|
| Çevre (mm)<br>Perimeter         | 95  |
| Alan (mm <sup>2</sup> )<br>Area | 94  |
| Ağırlık (gr/m)<br>Weight        | 255 |

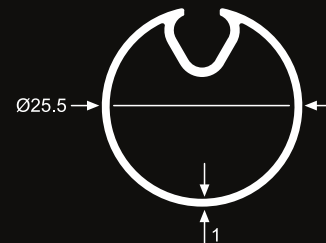

ÖZEL PROFİLLER  
SPECIAL PROFILES



Alaşım Alüminyum

|             |                                 |      |
|-------------|---------------------------------|------|
| <b>2089</b> | Çevre (mm)<br>Perimeter         | 306  |
|             | Alan (mm <sup>2</sup> )<br>Area | 790  |
|             | Ağırlık (gr/m)<br>Weight        | 2141 |

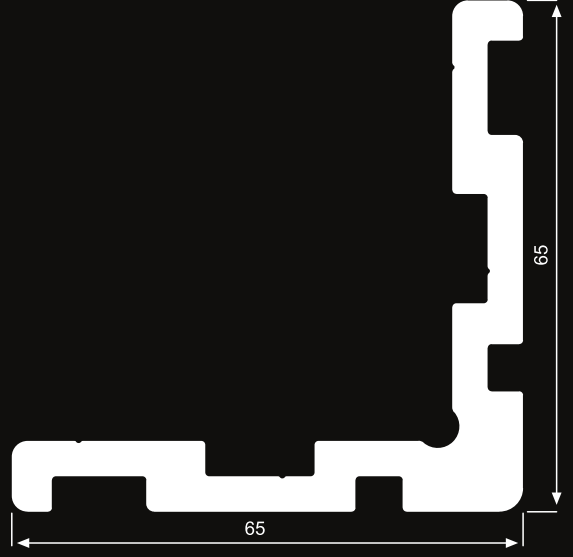

|             |                                 |       |
|-------------|---------------------------------|-------|
| <b>2090</b> | Çevre (mm)<br>Perimeter         | 292.5 |
|             | Alan (mm <sup>2</sup> )<br>Area | 180   |
|             | Ağırlık (gr/m)<br>Weight        | 487   |



|             |                                 |       |
|-------------|---------------------------------|-------|
| <b>2091</b> | Çevre (mm)<br>Perimeter         | 464.5 |
|             | Alan (mm <sup>2</sup> )<br>Area | 346.7 |
|             | Ağırlık (gr/m)<br>Weight        | 939   |

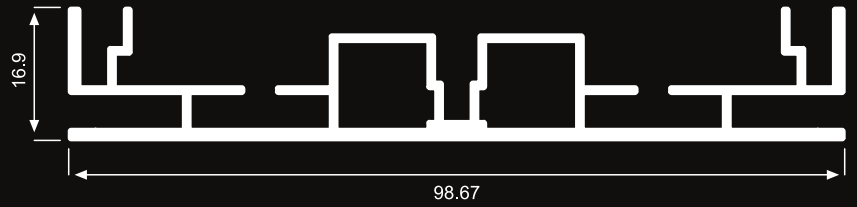

|             |                                 |     |
|-------------|---------------------------------|-----|
| <b>2101</b> | Çevre (mm)<br>Perimeter         | 136 |
|             | Alan (mm <sup>2</sup> )<br>Area | 68  |
|             | Ağırlık (gr/m)<br>Weight        | 183 |

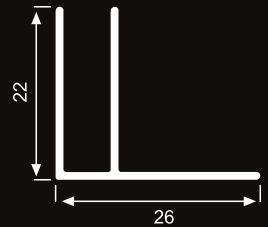



Alaşım Alüminyum

|             |                                 |     |
|-------------|---------------------------------|-----|
| <b>2145</b> | Çevre (mm)<br>Perimeter         | 73  |
|             | Alan (mm <sup>2</sup> )<br>Area | 134 |
|             | Ağırlık (gr/m)<br>Weight        | 363 |



|             |                                 |       |
|-------------|---------------------------------|-------|
| <b>2157</b> | Çevre (mm)<br>Perimeter         | 44.8  |
|             | Alan (mm <sup>2</sup> )<br>Area | 52.9  |
|             | Ağırlık (gr/m)<br>Weight        | 143.4 |

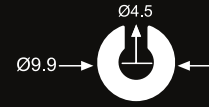

|             |                                 |        |
|-------------|---------------------------------|--------|
| <b>2158</b> | Çevre (mm)<br>Perimeter         | 227    |
|             | Alan (mm <sup>2</sup> )<br>Area | 485.7  |
|             | Ağırlık (gr/m)<br>Weight        | 1316.2 |

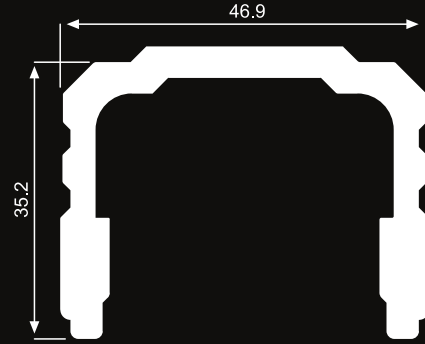

|             |                                 |       |
|-------------|---------------------------------|-------|
| <b>2159</b> | Çevre (mm)<br>Perimeter         | 297.9 |
|             | Alan (mm <sup>2</sup> )<br>Area | 348.9 |
|             | Ağırlık (gr/m)<br>Weight        | 945.5 |

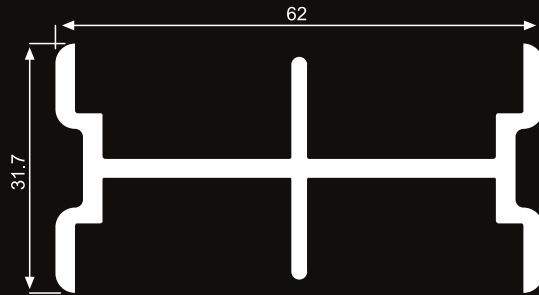

|             |                                 |      |
|-------------|---------------------------------|------|
| <b>2181</b> | Çevre (mm)<br>Perimeter         | 25.5 |
|             | Alan (mm <sup>2</sup> )<br>Area | 29.9 |
|             | Ağırlık (gr/m)<br>Weight        | 81   |

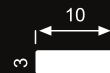

ÖZEL PROFİLLER  
SPECIAL PROFILES



Alaşım Alüminyum

|             |                                 |       |
|-------------|---------------------------------|-------|
| <b>2198</b> | Çevre (mm)<br>Perimeter         | 149.6 |
|             | Alan (mm <sup>2</sup> )<br>Area | 142   |
|             | Ağırlık (gr/m)<br>Weight        | 385   |

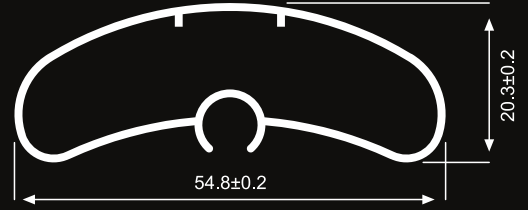

|             |                                 |     |
|-------------|---------------------------------|-----|
| <b>2200</b> | Çevre (mm)<br>Perimeter         | 132 |
|             | Alan (mm <sup>2</sup> )<br>Area | 360 |
|             | Ağırlık (gr/m)<br>Weight        | 976 |

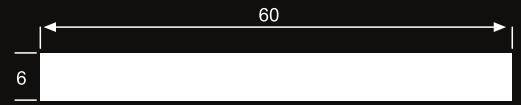

|             |                                 |       |
|-------------|---------------------------------|-------|
| <b>2207</b> | Çevre (mm)<br>Perimeter         | 318.9 |
|             | Alan (mm <sup>2</sup> )<br>Area | 285.4 |
|             | Ağırlık (gr/m)<br>Weight        | 773   |

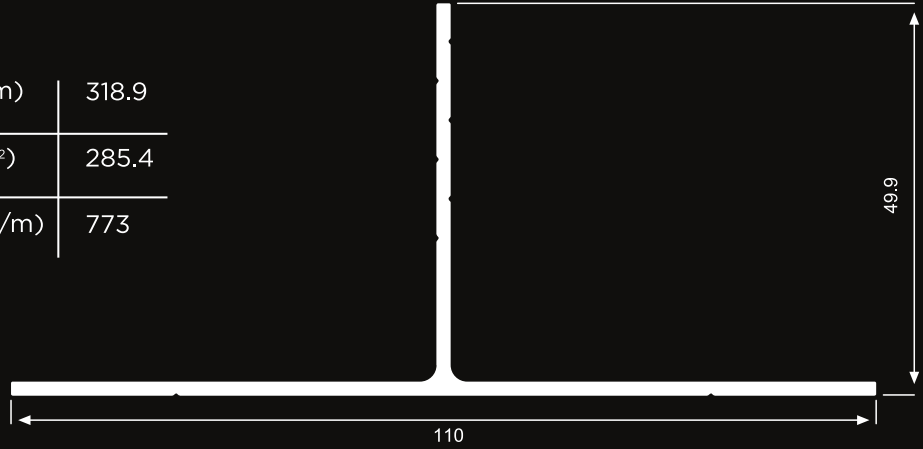

|             |                                 |       |
|-------------|---------------------------------|-------|
| <b>2209</b> | Çevre (mm)<br>Perimeter         | 278.9 |
|             | Alan (mm <sup>2</sup> )<br>Area | 249.3 |
|             | Ağırlık (gr/m)<br>Weight        | 676   |

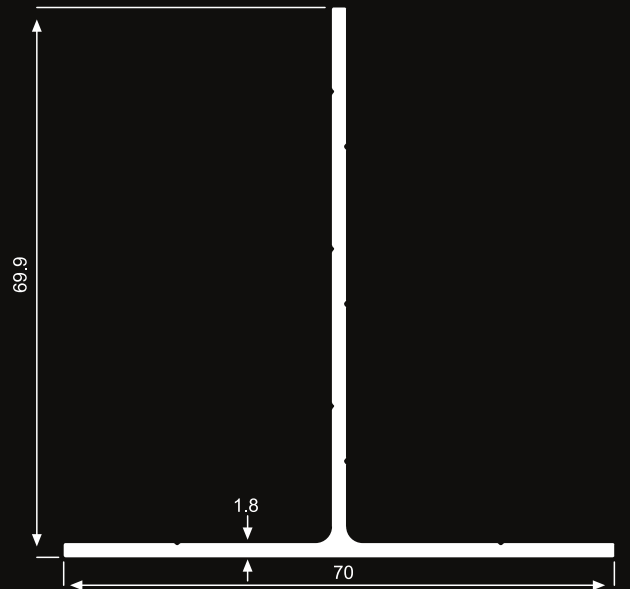



Alaşım Alüminyum

**2210**

|                                 |       |
|---------------------------------|-------|
| Çevre (mm)<br>Perimeter         | 214.4 |
| Alan (mm <sup>2</sup> )<br>Area | 108   |
| Ağırlık (gr/m)<br>Weight        | 293   |

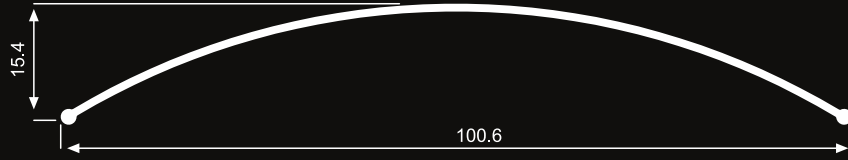

**2277**

|                                 |       |
|---------------------------------|-------|
| Çevre (mm)<br>Perimeter         | 145.7 |
| Alan (mm <sup>2</sup> )<br>Area | 73.8  |
| Ağırlık (gr/m)<br>Weight        | 200   |

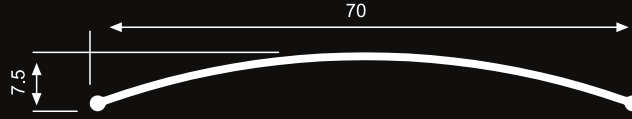

**2244**

|                                 |       |
|---------------------------------|-------|
| Çevre (mm)<br>Perimeter         | 451.1 |
| Alan (mm <sup>2</sup> )<br>Area | 412.2 |
| Ağırlık (gr/m)<br>Weight        | 1117  |

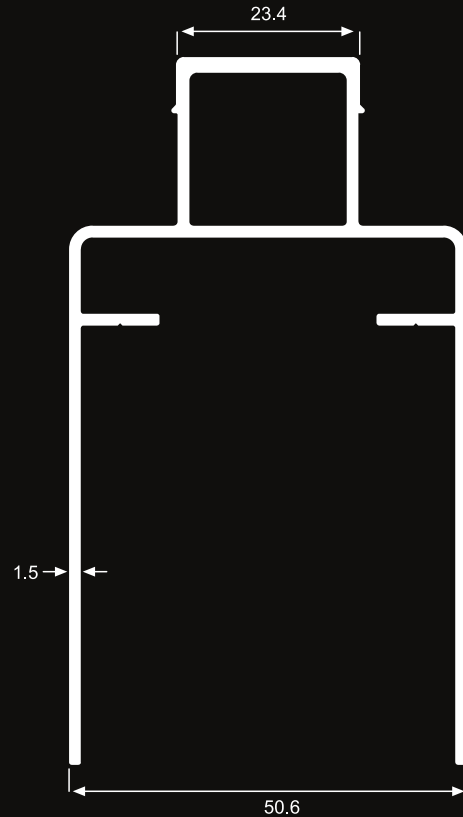

ÖZEL PROFİLLER  
SPECIAL PROFILES



Alaşım Alüminyum

**2246**

|                                 |       |
|---------------------------------|-------|
| Çevre (mm)<br>Perimeter         | 198.7 |
| Alan (mm <sup>2</sup> )<br>Area | 802.3 |
| Ağırlık (gr/m)<br>Weight        | 2174  |

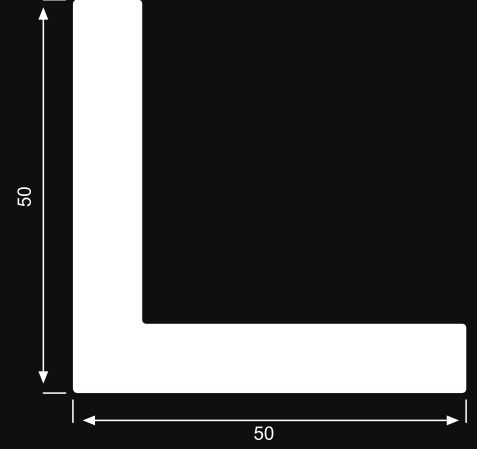

**2248**

|                                 |       |
|---------------------------------|-------|
| Çevre (mm)<br>Perimeter         | 218   |
| Alan (mm <sup>2</sup> )<br>Area | 423.9 |
| Ağırlık (gr/m)<br>Weight        | 1149  |

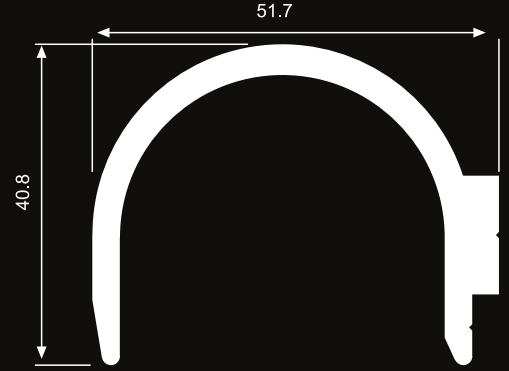

**2268**

|                                 |      |
|---------------------------------|------|
| Çevre (mm)<br>Perimeter         | 271  |
| Alan (mm <sup>2</sup> )<br>Area | 772  |
| Ağırlık (gr/m)<br>Weight        | 2092 |

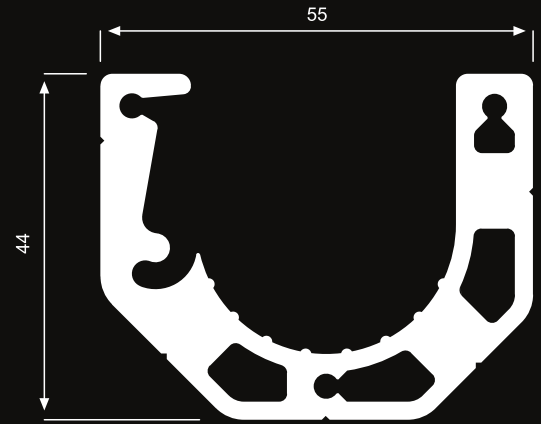

**2269**

|                                 |     |
|---------------------------------|-----|
| Çevre (mm)<br>Perimeter         | 54  |
| Alan (mm <sup>2</sup> )<br>Area | 79  |
| Ağırlık (gr/m)<br>Weight        | 214 |







Alaşım Alüminyum

**2280**

|  |     |
|--|-----|
| Çevre (mm)<br><i>Perimeter</i>         | 131 |
| Alan (mm <sup>2</sup> )<br><i>Area</i> | 116 |
| Ağırlık (gr/m)<br><i>Weight</i>        | 314 |

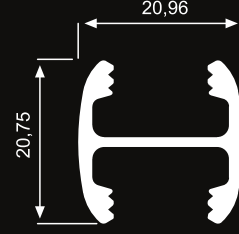

**2303**

|  |       |
|--|-------|
| Çevre (mm)<br><i>Perimeter</i>         | 172,5 |
| Alan (mm <sup>2</sup> )<br><i>Area</i> | 232,6 |
| Ağırlık (gr/m)<br><i>Weight</i>        | 630   |

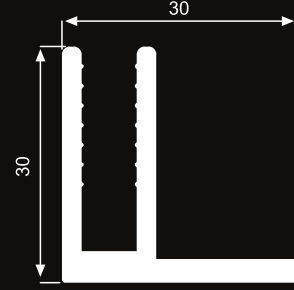

**2304**

|  |     |
|--|-----|
| Çevre (mm)<br><i>Perimeter</i>         | 138 |
| Alan (mm <sup>2</sup> )<br><i>Area</i> | 139 |
| Ağırlık (gr/m)<br><i>Weight</i>        | 376 |



**2305**

|  |       |
|--|-------|
| Çevre (mm)<br><i>Perimeter</i>         | 215,4 |
| Alan (mm <sup>2</sup> )<br><i>Area</i> | 211,5 |
| Ağırlık (gr/m)<br><i>Weight</i>        | 573   |

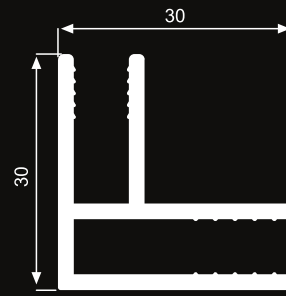

ÖZEL PROFİLLER  
SPECIAL PROFILES



Alaşım Alüminyum

|             |                                 |       |
|-------------|---------------------------------|-------|
| <b>2325</b> | Çevre (mm)<br>Perimeter         | 254,4 |
|             | Alan (mm <sup>2</sup> )<br>Area | 159,8 |
|             | Ağırlık (gr/m)<br>Weight        | 432   |

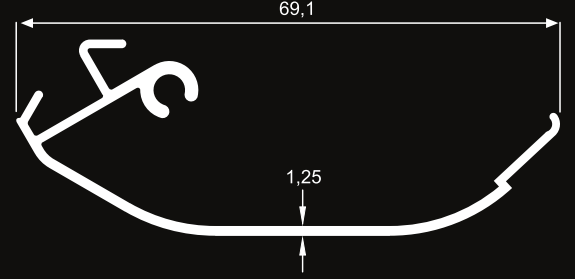

|             |                                 |       |
|-------------|---------------------------------|-------|
| <b>2326</b> | Çevre (mm)<br>Perimeter         | 356,6 |
|             | Alan (mm <sup>2</sup> )<br>Area | 241,3 |
|             | Ağırlık (gr/m)<br>Weight        | 654   |

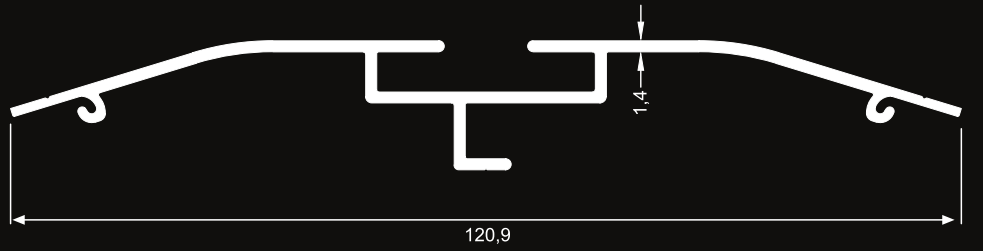

|             |                                 |       |
|-------------|---------------------------------|-------|
| <b>2339</b> | Çevre (mm)<br>Perimeter         | 396,8 |
|             | Alan (mm <sup>2</sup> )<br>Area | 275,3 |
|             | Ağırlık (gr/m)<br>Weight        | 746   |

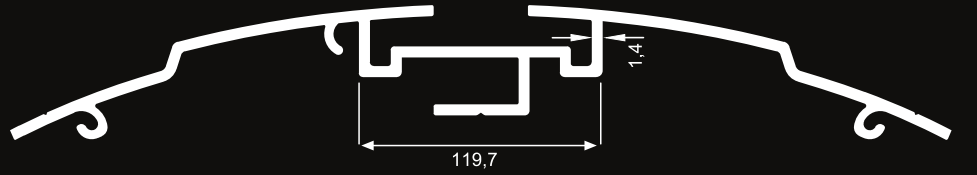

|             |                                 |     |
|-------------|---------------------------------|-----|
| <b>2340</b> | Çevre (mm)<br>Perimeter         | 207 |
|             | Alan (mm <sup>2</sup> )<br>Area | 142 |
|             | Ağırlık (gr/m)<br>Weight        | 385 |

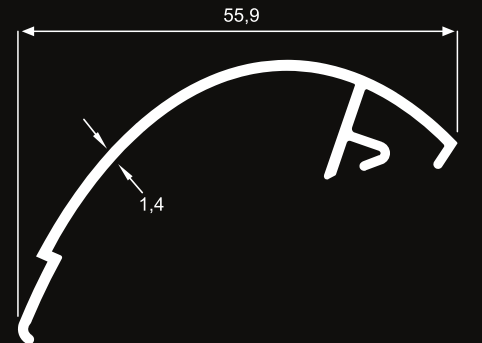



Alaşım Alüminyum

**2341**

|  |       |
|--|-------|
| Çevre (mm)<br><i>Perimeter</i>         | 361   |
| Alan (mm <sup>2</sup> )<br><i>Area</i> | 248,4 |
| Ağırlık (gr/m)<br><i>Weight</i>        | 673   |

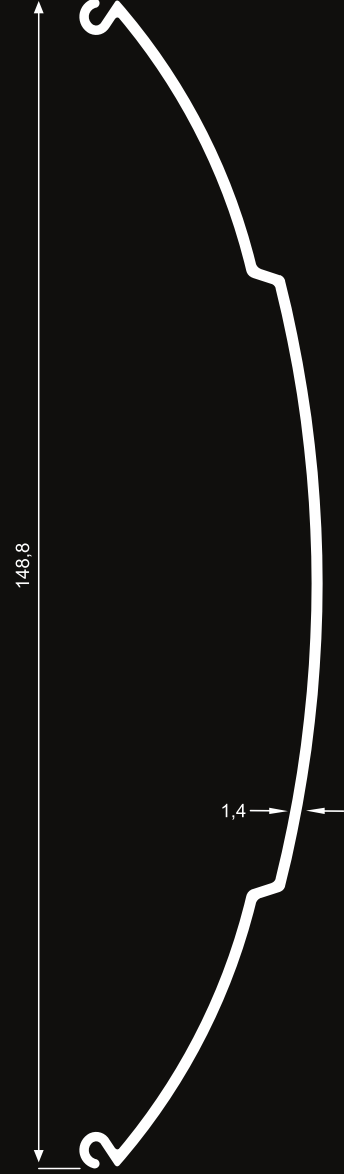

ÖZEL PROFİLLER  
SPECIAL PROFILES



Alaşım Alüminyum

|             |  |       |
|-------------|--|-------|
| <b>2344</b> | Çevre (mm)<br><i>Perimeter</i>         | 265,6 |
|             | Alan (mm <sup>2</sup> )<br><i>Area</i> | 391,4 |
|             | Ağırlık (gr/m)<br><i>Weight</i>        | 1060  |

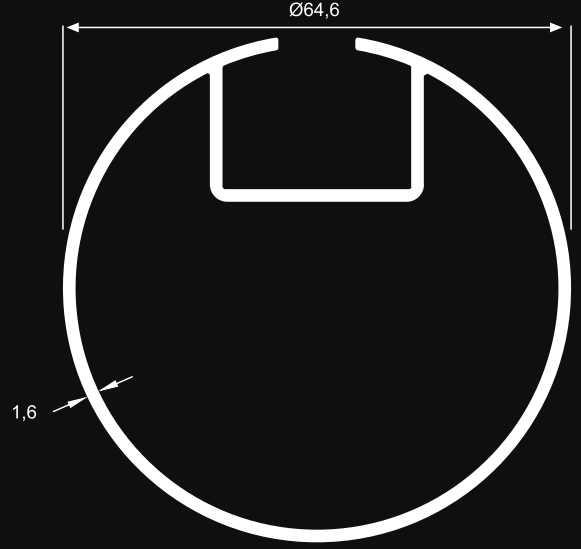

|             |  |     |
|-------------|--|-----|
| <b>2348</b> | Çevre (mm)<br><i>Perimeter</i>         | 69  |
|             | Alan (mm <sup>2</sup> )<br><i>Area</i> | 119 |
|             | Ağırlık (gr/m)<br><i>Weight</i>        | 322 |

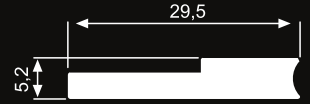

|             |  |       |
|-------------|--|-------|
| <b>2349</b> | Çevre (mm)<br><i>Perimeter</i>         | 273,7 |
|             | Alan (mm <sup>2</sup> )<br><i>Area</i> | 616,3 |
|             | Ağırlık (gr/m)<br><i>Weight</i>        | 1670  |

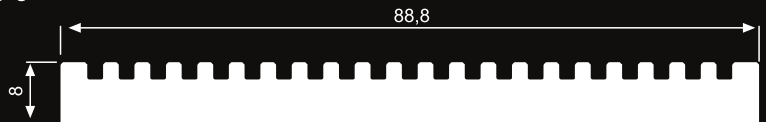



Alaşım Alüminyum

**2350**

|                                 |       |
|---------------------------------|-------|
| Çevre (mm)<br>Perimeter         | 135,9 |
| Alan (mm <sup>2</sup> )<br>Area | 498,1 |
| Ağırlık (gr/m)<br>Weight        | 1349  |

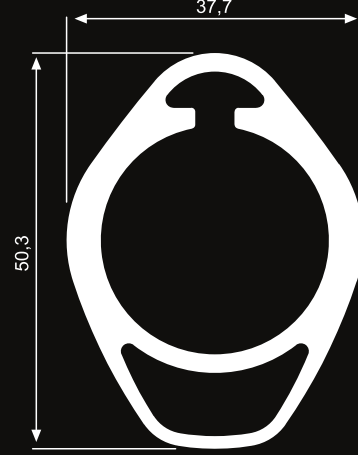

**2351**

|                                 |       |
|---------------------------------|-------|
| Çevre (mm)<br>Perimeter         | 297,8 |
| Alan (mm <sup>2</sup> )<br>Area | 645,4 |
| Ağırlık (gr/m)<br>Weight        | 1749  |

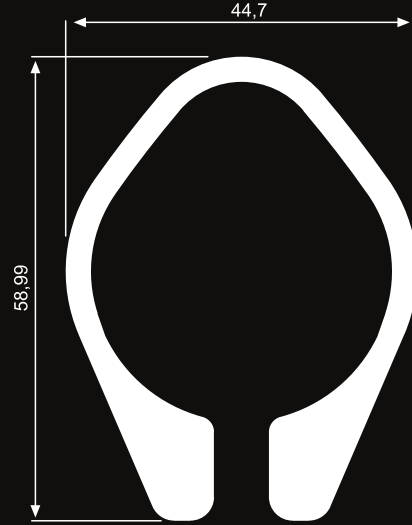

**2352**

|                                 |        |
|---------------------------------|--------|
| Çevre (mm)<br>Perimeter         | 303,6  |
| Alan (mm <sup>2</sup> )<br>Area | 1116,4 |
| Ağırlık (gr/m)<br>Weight        | 3025   |

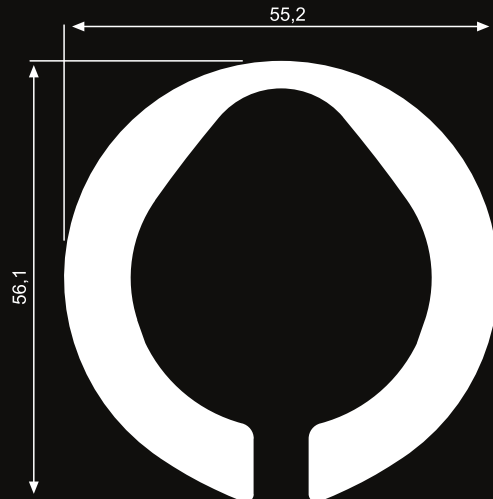

ÖZEL PROFİLLER  
SPECIAL PROFILES



Alaşım Alüminyum

|             |  |       |
|-------------|--|-------|
| <b>2423</b> | Çevre (mm)<br><i>Perimeter</i>         | 186,3 |
|             | Alan (mm <sup>2</sup> )<br><i>Area</i> | 440   |
|             | Ağırlık (gr/m)<br><i>Weight</i>        | 1192  |

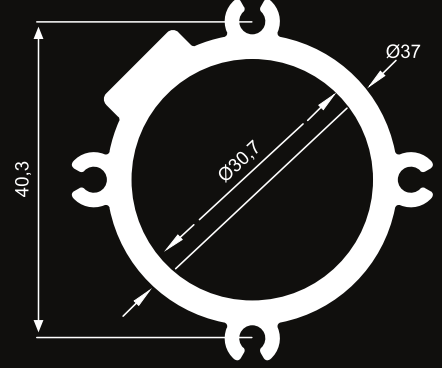

|             |  |       |
|-------------|--|-------|
| <b>2431</b> | Çevre (mm)<br><i>Perimeter</i>         | 183,3 |
|             | Alan (mm <sup>2</sup> )<br><i>Area</i> | 225,2 |
|             | Ağırlık (gr/m)<br><i>Weight</i>        | 610   |

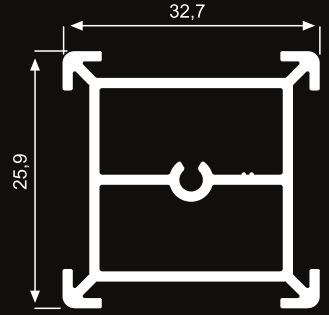

|             |  |       |
|-------------|--|-------|
| <b>2442</b> | Çevre (mm)<br><i>Perimeter</i>         | 147,8 |
|             | Alan (mm <sup>2</sup> )<br><i>Area</i> | 127,2 |
|             | Ağırlık (gr/m)<br><i>Weight</i>        | 344   |

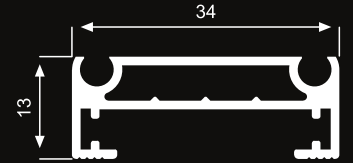

|             |  |       |
|-------------|--|-------|
| <b>2443</b> | Çevre (mm)<br><i>Perimeter</i>         | 196,6 |
|             | Alan (mm <sup>2</sup> )<br><i>Area</i> | 506,6 |
|             | Ağırlık (gr/m)<br><i>Weight</i>        | 1372  |





Alaşım Alüminyum

**2445**

|                                 |     |
|---------------------------------|-----|
| Çevre (mm)<br>Perimeter         | 227 |
| Alan (mm <sup>2</sup> )<br>Area | 117 |
| Ağırlık (gr/m)<br>Weight        | 317 |

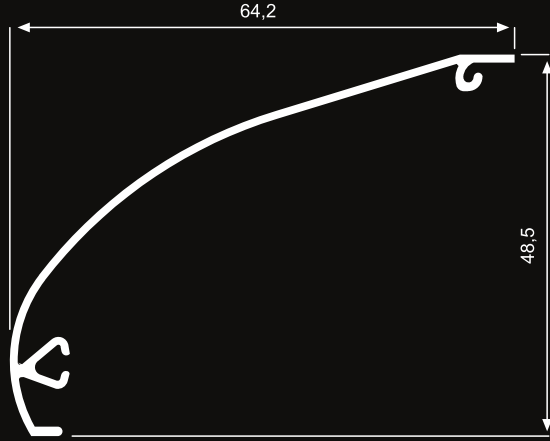

**2446**

|                                 |     |
|---------------------------------|-----|
| Çevre (mm)<br>Perimeter         | 222 |
| Alan (mm <sup>2</sup> )<br>Area | 140 |
| Ağırlık (gr/m)<br>Weight        | 380 |

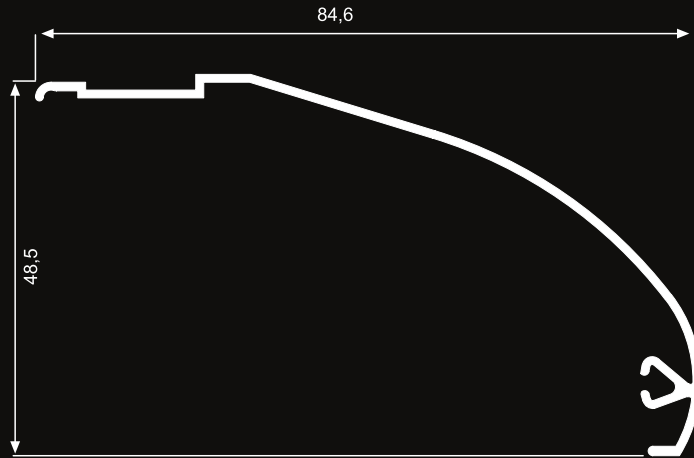

**2447**

|                                 |       |
|---------------------------------|-------|
| Çevre (mm)<br>Perimeter         | 338,9 |
| Alan (mm <sup>2</sup> )<br>Area | 253   |
| Ağırlık (gr/m)<br>Weight        | 685   |

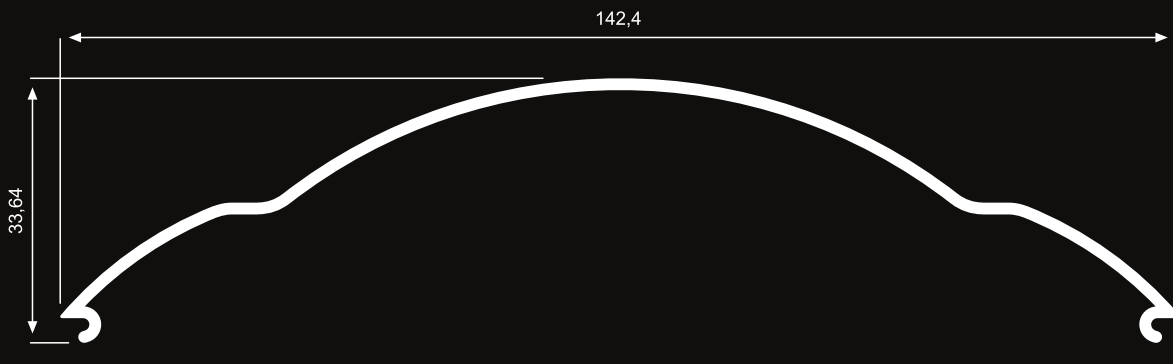

ÖZEL PROFİLLER  
SPECIAL PROFILES



Alaşım Alüminyum

|             |  |    |
|-------------|--|----|
| <b>2451</b> | Çevre (mm)<br><i>Perimeter</i>         | 32 |
|             | Alan (mm <sup>2</sup> )<br><i>Area</i> | 36 |
|             | Ağırlık (gr/m)<br><i>Weight</i>        | 98 |

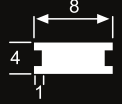

|             |  |     |
|-------------|--|-----|
| <b>2452</b> | Çevre (mm)<br><i>Perimeter</i>         | 38  |
|             | Alan (mm <sup>2</sup> )<br><i>Area</i> | 48  |
|             | Ağırlık (gr/m)<br><i>Weight</i>        | 130 |

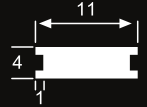

|             |  |       |
|-------------|--|-------|
| <b>2453</b> | Çevre (mm)<br><i>Perimeter</i>         | 159,6 |
|             | Alan (mm <sup>2</sup> )<br><i>Area</i> | 76,5  |
|             | Ağırlık (gr/m)<br><i>Weight</i>        | 207,3 |

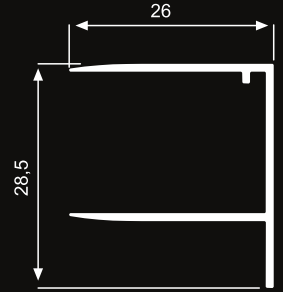

|               |  |       |
|---------------|--|-------|
| <b>2464-R</b> | Çevre (mm)<br><i>Perimeter</i>         | 524,3 |
|               | Alan (mm <sup>2</sup> )<br><i>Area</i> | 518,5 |
|               | Ağırlık (gr/m)<br><i>Weight</i>        | 1405  |

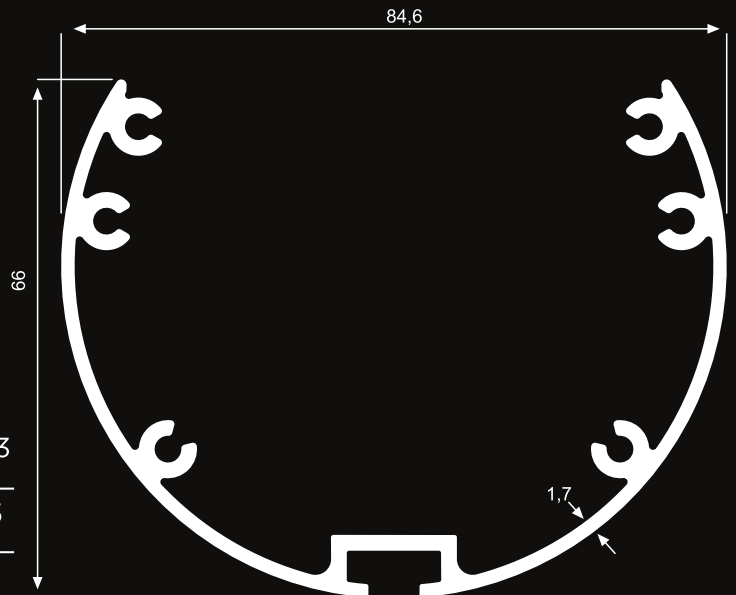





Alaşım Alüminyum

**2465**

|                                 |      |
|---------------------------------|------|
| Çevre (mm)<br>Perimeter         | 300  |
| Alan (mm <sup>2</sup> )<br>Area | 986  |
| Ağırlık (gr/m)<br>Weight        | 2672 |

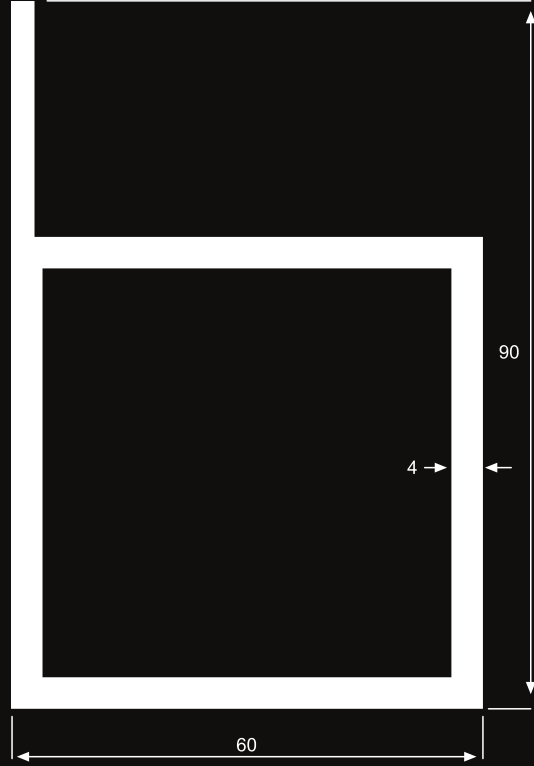

**2466**

|                                 |      |
|---------------------------------|------|
| Çevre (mm)<br>Perimeter         | 360  |
| Alan (mm <sup>2</sup> )<br>Area | 1076 |
| Ağırlık (gr/m)<br>Weight        | 2915 |

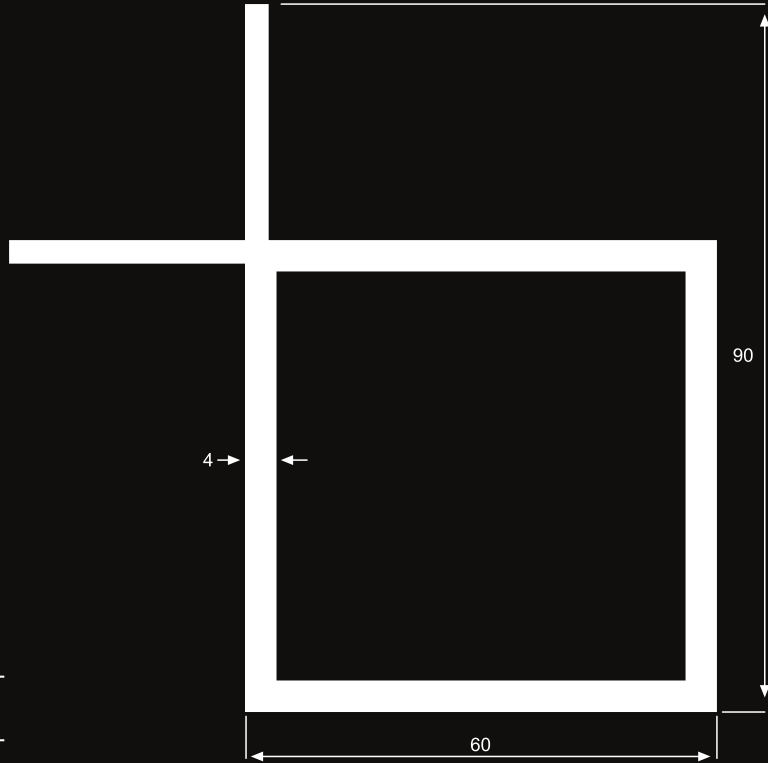

ÖZEL PROFİLLER  
SPECIAL PROFILES



Alaşım Alüminyum

|             |  |       |
|-------------|--|-------|
| <b>2467</b> | Çevre (mm)<br><i>Perimeter</i>         | 167   |
|             | Alan (mm <sup>2</sup> )<br><i>Area</i> | 58,5  |
|             | Ağırlık (gr/m)<br><i>Weight</i>        | 158,5 |

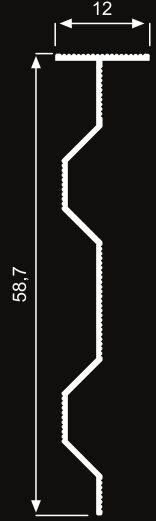

|             |  |       |
|-------------|--|-------|
| <b>2486</b> | Çevre (mm)<br><i>Perimeter</i>         | 456,2 |
|             | Alan (mm <sup>2</sup> )<br><i>Area</i> | 341,2 |
|             | Ağırlık (gr/m)<br><i>Weight</i>        | 924,7 |

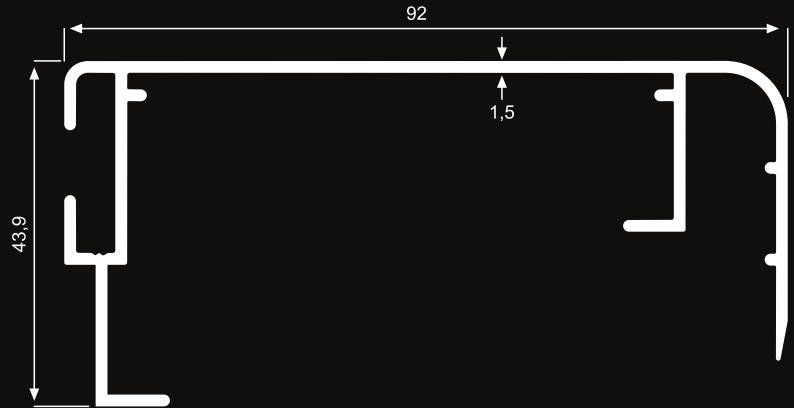

|             |  |       |
|-------------|--|-------|
| <b>2485</b> | Çevre (mm)<br><i>Perimeter</i>         | 410,2 |
|             | Alan (mm <sup>2</sup> )<br><i>Area</i> | 306,7 |
|             | Ağırlık (gr/m)<br><i>Weight</i>        | 831,2 |

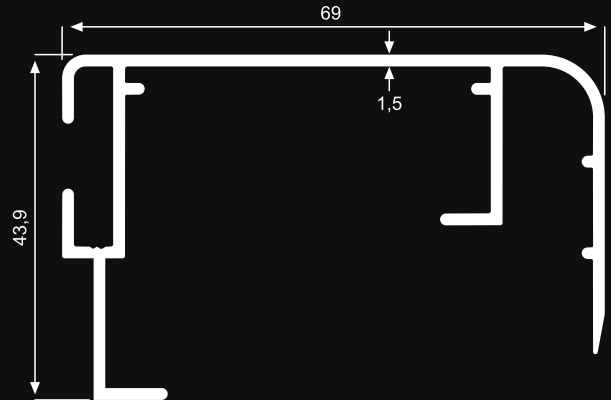



Alaşım Alüminyum

**2493**

|  |     |
|--|-----|
| Çevre (mm)<br><i>Perimeter</i>         | 78  |
| Alan (mm <sup>2</sup> )<br><i>Area</i> | 95  |
| Ağırlık (gr/m)<br><i>Weight</i>        | 257 |



**2494**

|  |     |
|--|-----|
| Çevre (mm)<br><i>Perimeter</i>         | 188 |
| Alan (mm <sup>2</sup> )<br><i>Area</i> | 205 |
| Ağırlık (gr/m)<br><i>Weight</i>        | 555 |

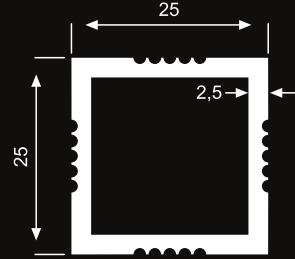

**2495**

|  |     |
|--|-----|
| Çevre (mm)<br><i>Perimeter</i>         | 97  |
| Alan (mm <sup>2</sup> )<br><i>Area</i> | 133 |
| Ağırlık (gr/m)<br><i>Weight</i>        | 360 |

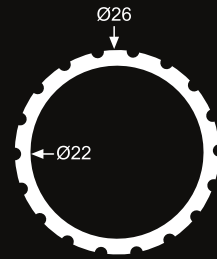

ÖZEL PROFİLLER  
SPECIAL PROFILES



Alaşım Alüminyum

|             |  |        |
|-------------|--|--------|
| <b>2501</b> | Çevre (mm)<br><i>Perimeter</i>         | 179,1  |
|             | Alan (mm <sup>2</sup> )<br><i>Area</i> | 389,2  |
|             | Ağırlık (gr/m)<br><i>Weight</i>        | 1054,7 |

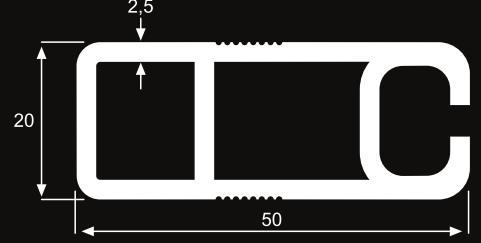

|             |  |       |
|-------------|--|-------|
| <b>2502</b> | Çevre (mm)<br><i>Perimeter</i>         | 179,1 |
|             | Alan (mm <sup>2</sup> )<br><i>Area</i> | 327,5 |
|             | Ağırlık (gr/m)<br><i>Weight</i>        | 887,5 |

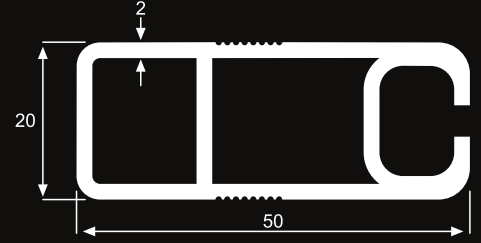

|             |  |       |
|-------------|--|-------|
| <b>2503</b> | Çevre (mm)<br><i>Perimeter</i>         | 135,2 |
|             | Alan (mm <sup>2</sup> )<br><i>Area</i> | 279,7 |
|             | Ağırlık (gr/m)<br><i>Weight</i>        | 758   |

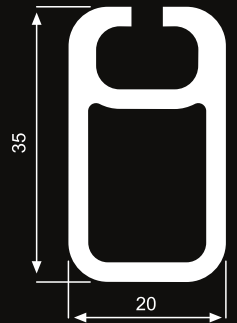



Alaşım Alüminyum

**2372**

|  |       |
|--|-------|
| Çevre (mm)<br><i>Perimeter</i>         | 231,9 |
| Alan (mm <sup>2</sup> )<br><i>Area</i> | 292,3 |
| Ağırlık (gr/m)<br><i>Weight</i>        | 792   |

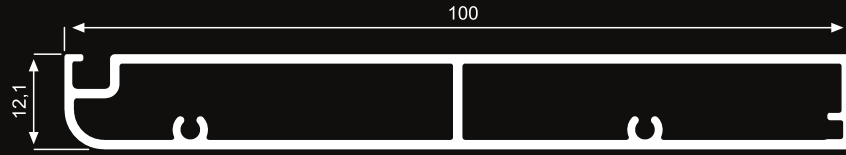

**2409**

|  |     |
|--|-----|
| Çevre (mm)<br><i>Perimeter</i>         | 289 |
| Alan (mm <sup>2</sup> )<br><i>Area</i> | 212 |
| Ağırlık (gr/m)<br><i>Weight</i>        | 575 |

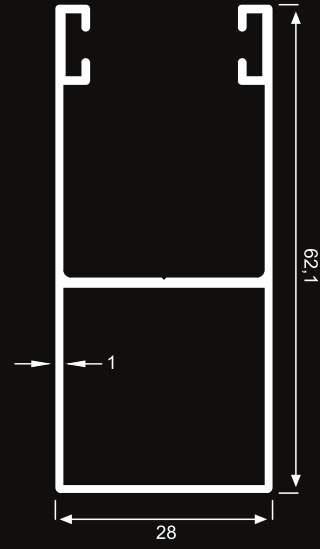

**2410**

|  |       |
|--|-------|
| Çevre (mm)<br><i>Perimeter</i>         | 232,2 |
| Alan (mm <sup>2</sup> )<br><i>Area</i> | 130   |
| Ağırlık (gr/m)<br><i>Weight</i>        | 352   |

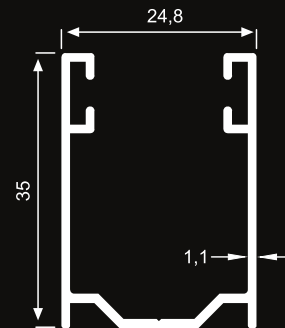

KEPENK (PANJUR)  
SHUTTER PROFILES



Alaşım Alüminyum

|             |  |       |
|-------------|--|-------|
| <b>2411</b> | Çevre (mm)<br><i>Perimeter</i>         | 255,6 |
|             | Alan (mm <sup>2</sup> )<br><i>Area</i> | 139,7 |
|             | Ağırlık (gr/m)<br><i>Weight</i>        | 375   |

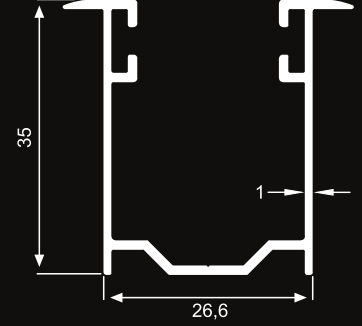

|             |  |       |
|-------------|--|-------|
| <b>2412</b> | Çevre (mm)<br><i>Perimeter</i>         | 176,8 |
|             | Alan (mm <sup>2</sup> )<br><i>Area</i> | 124   |
|             | Ağırlık (gr/m)<br><i>Weight</i>        | 335   |



|             |  |       |
|-------------|--|-------|
| <b>2413</b> | Çevre (mm)<br><i>Perimeter</i>         | 342,6 |
|             | Alan (mm <sup>2</sup> )<br><i>Area</i> | 304   |
|             | Ağırlık (gr/m)<br><i>Weight</i>        | 825   |

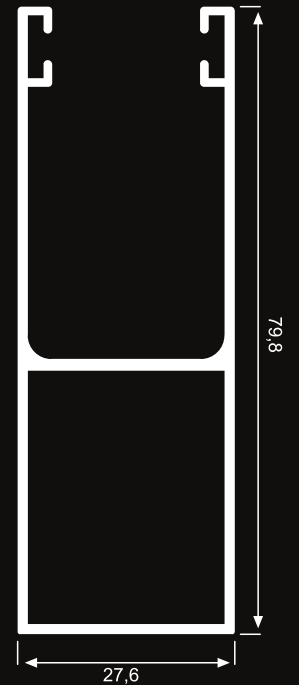





Alaşım Alüminyum





Alaşım Alüminyum

**Adres:** Beylikdüzü OSB Mahallesi Birlik Sanayi Sitesi 3. Cad. No: 67, 34524 Beylikdüzü / İSTANBUL  
Tel:0212 876 01 51 Fax:0212 876 01 67 Gsm:0532 231 49 70 Email:info@alasaluminyum.com